



TABLE OF CONTENTS

1.DATA SHEET

PAGE 1

2.MARKING

PAGE 5

3.TAPING

PAGE 6

4.PACKING

PAGE 7

5.HIGH RELIABILITY TEST SPEC.

PAGE 12



P6KE SERIES

GLASS PASSIVATED JUNCTION TRANSIENT VOLTAGE SUPPRESSOR POWER 600 Watts

BREAK DOWN VOLTAGE

6.8 to 550 Volts

DO-15

Unit: inch(mm)

Recongized File # E210467

FEATURES

- Plastic package has Underwriters Laboratory Flammability Classification 94V-O
- Typical IR less than 1μA above 10V
- 600W surge capability at 1ms
- Excellent clamping capability
- Low zener impedance
- Fast response time: typically less than 1.0 ps from 0 volts to BV min
- In compliance with EU RoHS 2002/95/EC directives

MECHANICAL DATA

- Case: JEDEC DO-15 Molded plastic
- Terminals: Axial leads, solderable per MIL-STD-750, Method 2026
- Polarity: Color band denoted cathode except Bipolar
- Mounting Position: Any
- Weight: 0.014 ounce, 0.397 gram

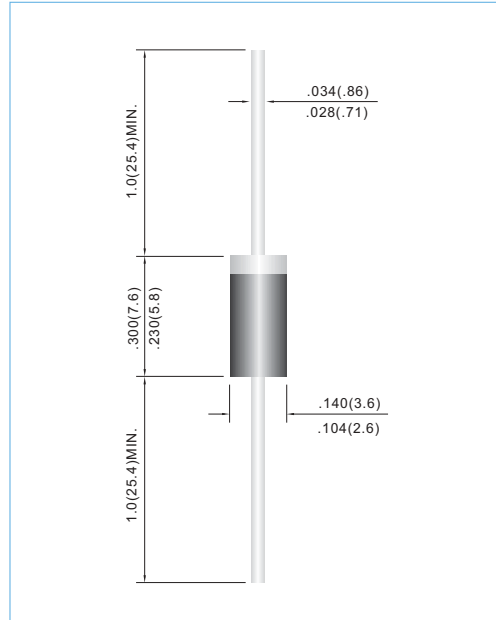

DEVICES FOR BIPOLAR APPLICATIONS

For Bidirectional use C or CA Suffix for types
Electrical characteristics apply in both directions.

MAXIMUM RATINGS AND CHARACTERISTICS

Rating at 25°C ambient temperature unless otherwise specified. Resistive or inductive load, 60Hz.
For Capacitive load derate current by 20%.

Rating	Symbol	Value	Units
Power Dissipation on $T_A = 25^\circ\text{C}$, $T_p = 1\text{ms}$ (Note 1)	P_{PK}	600	Watts
Typical Thermal Resistance Junction to Air Lead Lengths .375", (9.5mm) (Note 2)	$R_{\theta JA}$	45	$^\circ\text{C} / \text{W}$
Peak Forward Surge Current, 8.3ms Single Half Sine-Wave Superimposed on Rated Load (JEDEC Method) (Note 3)	I_{FSM}	100	Amps
Operating Junction and Storage Temperature Range	T_J, T_{STG}	-65 to +175	$^\circ\text{C}$

NOTES:

1. Non-repetitive current pulse, per Fig. 3 and derated above $T_A = 25^\circ\text{C}$ per Fig. 2.
2. Mounted on Copper Leaf area of 1.57 in² (40mm²).
3. 8.3ms single half sine-wave, duty cycle= 4 pulses per minutes maximum.



P6KE SERIES

Part Number	Part Number	V _{RWM}	V _{BR} @ I _T			I _R @ V _{RWM}		V _C @ I _{PP}		Marking Code	
			Min.	Max.	I _T	UNI-	BI-	V	A	UNI-	BI-
UNI-	BI-	V	V	V	mA	μA	μA	V	A	UNI-	BI-
600W Transient Voltage Suppressor											
P6KE6.8	P6KE6.8C	5.5	6.12	7.48	10	1000	2000	10.8	56	P6KE6.8	P6KE6.8C
P6KE6.8A	P6KE6.8CA	5.8	6.45	7.14	10	1000	2000	10.5	57	P6KE6.8A	P6KE6.8CA
P6KE7.5	P6KE7.5C	6.05	6.75	8.25	10	500	1000	11.7	51	P6KE7.5	P6KE7.5C
P6KE7.5A	P6KE7.5CA	6.4	7.13	7.88	10	500	1000	11.3	53	P6KE7.5A	P6KE7.5CA
P6KE8.2	P6KE8.2C	6.63	7.38	9.02	10	200	400	12.5	48	P6KE8.2	P6KE8.2C
P6KE8.2A	P6KE8.2CA	7.02	7.79	8.61	10	200	400	12.1	50	P6KE8.2A	P6KE8.2CA
P6KE9.1	P6KE9.1C	7.37	8.19	10	1	50	100	13.8	44	P6KE9.1	P6KE9.1C
P6KE9.1A	P6KE9.1CA	7.78	8.65	9.50	1	50	100	13.4	45	P6KE9.1A	P6KE9.1CA
P6KE10	P6KE10C	8.1	9	11	1	10	20	15	40	P6KE10	P6KE10C
P6KE10A	P6KE10CA	8.55	9.5	10.50	1	10	20	14.5	41	P6KE10A	P6KE10CA
P6KE11	P6KE11C	8.92	9.9	12	1	5	10	16.2	37	P6KE11	P6KE11C
P6KE11A	P6KE11CA	9.4	10.5	12	1	5	10	15.6	38	P6KE11A	P6KE11CA
P6KE12	P6KE12C	9.72	10.8	13	1	5	5	17.3	35	P6KE12	P6KE12C
P6KE12A	P6KE12CA	10.2	11.4	13	1	5	5	16.7	36	P6KE12A	P6KE12CA
P6KE13	P6KE13C	10.5	11.7	14	1	1	1	19	32	P6KE13	P6KE13C
P6KE13A	P6KE13CA	11.1	12.4	14	1	1	1	18.2	33	P6KE13A	P6KE13CA
P6KE15	P6KE15C	12.1	13.5	16.5	1	1	1	22	27	P6KE15	P6KE15C
P6KE15A	P6KE15CA	12.8	14.3	15.8	1	1	1	21.2	28	P6KE15A	P6KE15CA
P6KE16	P6KE16C	12.9	14.4	17.6	1	1	1	23.5	26	P6KE16	P6KE16C
P6KE16A	P6KE16CA	13.6	15.2	16.8	1	1	1	22.5	27	P6KE16A	P6KE16CA
P6KE18	P6KE18C	14.5	16.2	19.8	1	1	1	26.5	23	P6KE18	P6KE18C
P6KE18A	P6KE18CA	15.3	17.1	18.9	1	1	1	25.2	24	P6KE18A	P6KE18CA
P6KE20	P6KE20C	16.2	18	22	1	1	1	29.1	21	P6KE20	P6KE20C
P6KE20A	P6KE20CA	17.1	19	21	1	1	1	27.7	22	P6KE20A	P6KE20CA
P6KE22	P6KE22C	17.8	19.8	24.2	1	1	1	31.9	19	P6KE22	P6KE22C
P6KE22A	P6KE22CA	18.8	20.9	23.1	1	1	1	30.6	20	P6KE22A	P6KE22CA
P6KE24	P6KE24C	19.4	21.6	26.4	1	1	1	34.7	17	P6KE24	P6KE24C
P6KE24A	P6KE24CA	20.5	22.8	25.2	1	1	1	33.2	18	P6KE24A	P6KE24CA
P6KE27	P6KE27C	21.8	24.3	29.7	1	1	1	39.1	15	P6KE27	P6KE27C
P6KE27A	P6KE27CA	23.1	25.7	28.4	1	1	1	37.5	16	P6KE27A	P6KE27CA
P6KE30	P6KE30C	24.3	27	33	1	1	1	43.5	14	P6KE30	P6KE30C
P6KE30A	P6KE30CA	25.6	28.5	31.5	1	1	1	41.4	14.4	P6KE30A	P6KE30CA
P6KE33	P6KE33C	26.8	29.7	36.3	1	1	1	47.7	12.6	P6KE33	P6KE33C
P6KE33A	P6KE33CA	28.2	31.4	34.7	1	1	1	45.7	13.2	P6KE33A	P6KE33CA
P6KE36	P6KE36C	29.1	32.4	39.6	1	1	1	52	11.6	P6KE36	P6KE36C
P6KE36A	P6KE36CA	30.8	34.2	37.8	1	1	1	49.9	12	P6KE36A	P6KE36CA
P6KE39	P6KE39C	31.6	35.1	42.9	1	1	1	56.4	10.6	P6KE39	P6KE39C
P6KE39A	P6KE39CA	33.3	37.1	41	1	1	1	53.9	11.2	P6KE39A	P6KE39CA
P6KE43	P6KE43C	34.8	38.7	47.3	1	1	1	61.9	9.6	P6KE43	P6KE43C
P6KE43A	P6KE43CA	36.8	40.9	45.2	1	1	1	59.3	10.1	P6KE43A	P6KE43CA
P6KE47	P6KE47C	38.1	42.3	51.7	1	1	1	67.8	8.9	P6KE47	P6KE47C
P6KE47A	P6KE47CA	40.2	44.7	49.4	1	1	1	64.8	9.3	P6KE47A	P6KE47CA



P6KE SERIES

Part Number	Part Number	V _{RWM}	V _{BR} @ I _T			I _R @ V _{RWM}		V _C @ I _{PP}		Marking Code	
			Min.	Max.	I _T	UNI-	BI-	V	A	UNI-	BI-
UNI-	BI-	V	V	V	mA	μA	μA	V	A	UNI-	BI-
600W Transient Voltage Suppressor											
P6KE51	P6KE51C	41.3	45.9	56.1	1	1	1	73.5	8.2	P6KE51	P6KE51C
P6KE51A	P6KE51CA	43.6	48.5	53.6	1	1	1	70.1	8.6	P6KE51A	P6KE51CA
P6KE56	P6KE56C	45.6	50.4	61.6	1	1	1	80.5	7.4	P6KE56	P6KE56C
P6KE56A	P6KE56CA	47.8	53.2	58.8	1	1	1	77	7.8	P6KE56A	P6KE56CA
P6KE62	P6KE62C	50.2	55.8	68.2	1	1	1	89	6.8	P6KE62	P6KE62C
P6KE62A	P6KE62CA	53	58.9	65.1	1	1	1	85	7.1	P6KE62A	P6KE62CA
P6KE68	P6KE68C	55.1	61.2	74.8	1	1	1	98	6.1	P6KE68	P6KE68C
P6KE68A	P6KE68CA	58.1	64.6	71.4	1	1	1	92	6.5	P6KE68A	P6KE68CA
P6KE75	P6KE75C	60.7	67.5	82.5	1	1	1	108	5.5	P6KE75	P6KE75C
P6KE75A	P6KE75CA	64.1	71.3	78.8	1	1	1	103	5.8	P6KE75A	P6KE75CA
P6KE82	P6KE82C	66.4	73.8	90.2	1	1	1	118	5.1	P6KE82	P6KE82C
P6KE82A	P6KE82CA	70.1	77.9	86.1	1	1	1	113	5.3	P6KE82A	P6KE82CA
P6KE91	P6KE91C	73.7	81.9	100	1	1	1	131	4.5	P6KE91	P6KE91C
P6KE91A	P6KE91CA	77.8	86.5	95.5	1	1	1	125	4.8	P6KE91A	P6KE91CA
P6KE100	P6KE100C	81	90	110	1	1	1	144	4.2	P6KE100	P6KE100C
P6KE100A	P6KE100CA	85.5	95	105	1	1	1	137	4.4	P6KE100A	P6KE100CA
P6KE110	P6KE110C	89.2	99	121	1	1	1	158	3.8	P6KE110	P6KE110C
P6KE110A	P6KE110CA	94	105	116	1	1	1	152	4	P6KE110A	P6KE110CA
P6KE120	P6KE120C	97.2	108	132	1	1	1	173	3.5	P6KE120	P6KE120C
P6KE120A	P6KE120CA	102	114	126	1	1	1	165	3.6	P6KE120A	P6KE120CA
P6KE130	P6KE130C	105	117	143	1	1	1	187	3.2	P6KE130	P6KE130C
P6KE130A	P6KE130CA	111	124	137	1	1	1	179	3.3	P6KE130A	P6KE130CA
P6KE150	P6KE150C	121	135	165	1	1	1	215	2.8	P6KE150	P6KE150C
P6KE150A	P6KE150CA	128	143	158	1	1	1	207	2.9	P6KE150A	P6KE150CA
P6KE160	P6KE160C	130	144	176	1	1	1	230	2.6	P6KE160	P6KE160C
P6KE160A	P6KE160CA	136	152	168	1	1	1	219	2.7	P6KE160A	P6KE160CA
P6KE170	P6KE170C	138	153	187	1	1	1	244	2.5	P6KE170	P6KE170C
P6KE170A	P6KE170CA	145	162	179	1	1	1	234	2.6	P6KE170A	P6KE170CA
P6KE180	P6KE180C	146	162	198	1	1	1	258	2.3	P6KE180	P6KE180C
P6KE180A	P6KE180CA	154	171	189	1	1	1	246	2.4	P6KE180A	P6KE180CA
P6KE200	P6KE200C	162	180	220	1	1	1	287	2.1	P6KE200	P6KE200C
P6KE200A	P6KE200CA	171	190	210	1	1	1	274	2.2	P6KE200A	P6KE200CA
P6KE220	P6KE220C	175	198	242	1	1	1	344	1.8	P6KE220	P6KE220C
P6KE220A	P6KE220CA	185	209	231	1	1	1	328	1.9	P6KE220A	P6KE220CA
P6KE250	P6KE250C	202	225	275	1	1	1	360	1.7	P6KE250	P6KE250C
P6KE250A	P6KE250CA	214	237	263	1	1	1	344	1.8	P6KE250A	P6KE250CA
P6KE300	P6KE300C	243	270	330	1	1	1	430	1.4	P6KE300	P6KE300C
P6KE300A	P6KE300CA	256	285	315	1	1	1	414	1.5	P6KE300A	P6KE300CA
P6KE350	P6KE350C	284	315	385	1	1	1	504	1.2	P6KE350	P6KE350C
P6KE350A	P6KE350CA	300	332	368	1	1	1	482	1.3	P6KE350A	P6KE350CA
P6KE400	P6KE400C	324	360	440	1	1	1	574	1.05	P6KE400	P6KE400C
P6KE400A	P6KE400CA	342	380	420	1	1	1	548	1.1	P6KE400A	P6KE400CA
P6KE440	P6KE440C	356	396	484	1	1	1	631	0.99	P6KE440	P6KE440C
P6KE440A	P6KE440CA	376	418	462	1	1	1	600	1.04	P6KE440A	P6KE440CA



P6KE SERIES

Part Number	Part Number	V _{RWM}	V _{BR} @ I _T			I _R @ V _{RWM}		V _C @ I _{PP}		Marking Code	
			Min.	Max.	I _T	UNI- μA	BI- μA	V	A	UNI-	BI-
		V	V	V	mA	μA	μA	V	A	UNI-	BI-
600W Transient Voltage Suppressor											
P6KE480	P6KE480C	389	432	528	1	1	1	691	0.87	P6KE480	P6KE480C
P6KE480A	P6KE480CA	408	456	504	1	1	1	658	0.91	P6KE480A	P6KE480CA
P6KE550	P6KE550C	445.5	495	605	1	1	1	792	0.76	P6KE550	P6KE550C
P6KE550A	P6KE550CA	467.5	522.5	577.5	1	1	1	753.5	0.8	P6KE550A	P6KE550CA

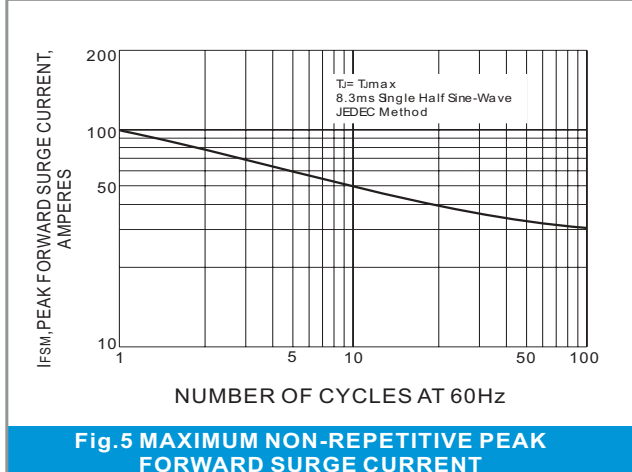
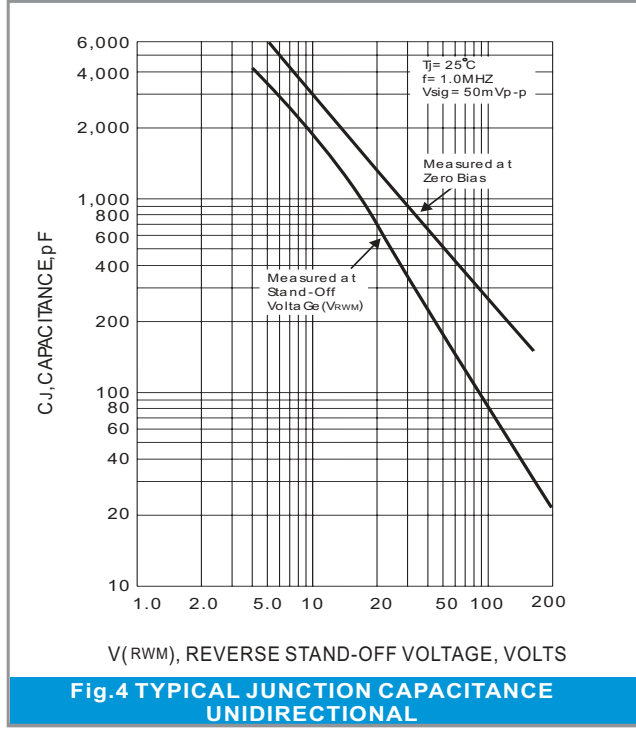
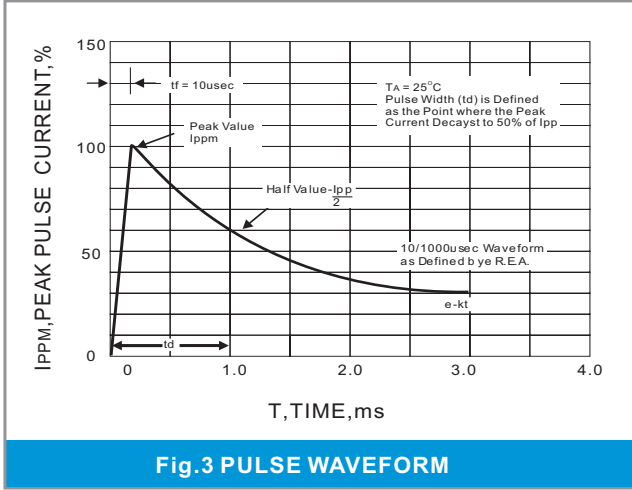
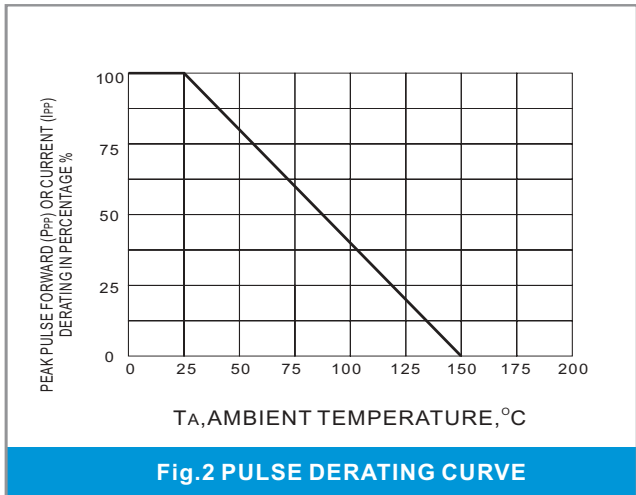
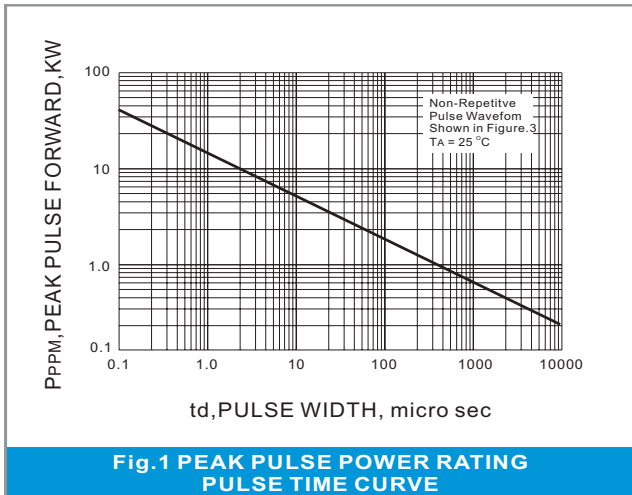



2. MARKING

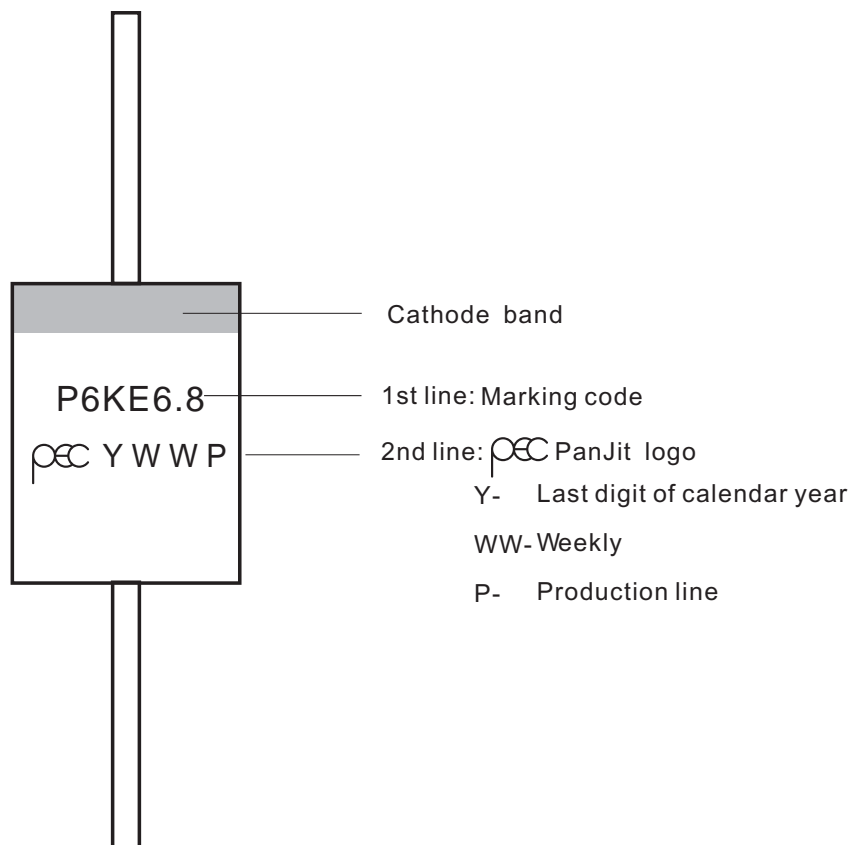



3. TAPING

Axial lead devices are packed in accordance with EIA standard RS-296-E and specifications given below.

COMPONENT OUTLINE	COMPONENT PITCH A ± 0.5mm	INTER TAPE PITCH B ± 1.0mm	CUMULATIVE PITCH TOLERANCE
DO-15	5.0mm	52.0mm	1.0mm/20pitch

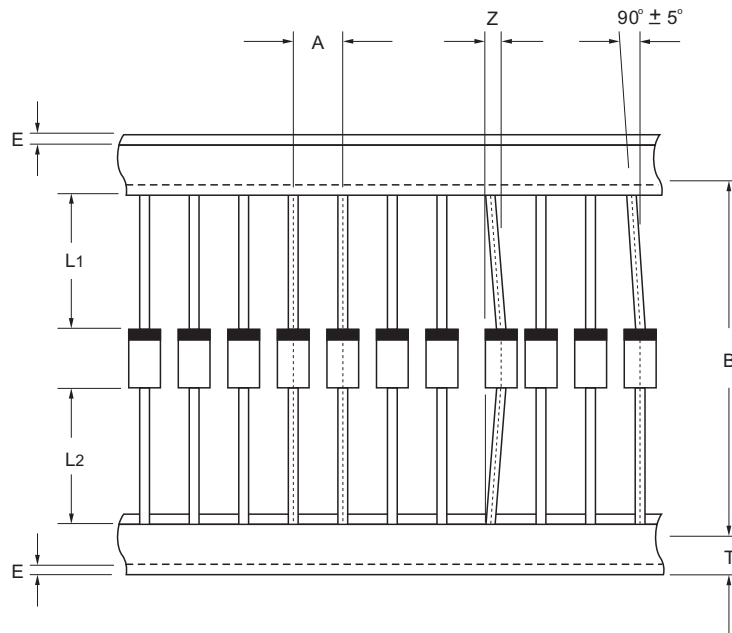

ITEM	SYMBOL	SPECIFICATIONS(mm)	SPECIFICATIONS(inch)
Component alignment	Z	1.2max	0.048max
Tape width	T	6.0±0.4	0.236±0.016
Exposed adhesive	E	0.8max	0.032max
Body eccentricity	L1-L2	1.0max	0.040max

NOTES: Each component lead shall be sandwiched between tapes for a minimum of 3.2mm (0.126")



4. PACKING

AMMUNITION PACKING

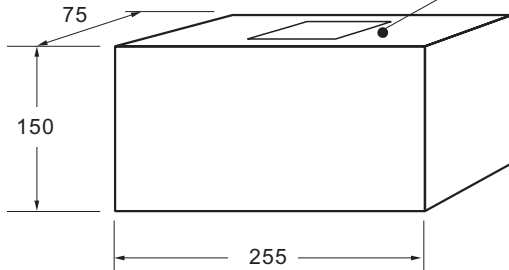

LABEL TYPE

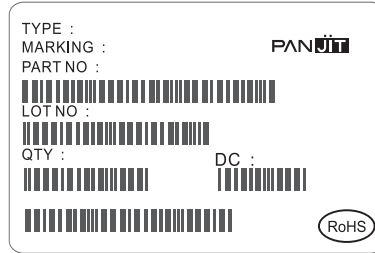

Box Dimensions : mm
Quantity per Box: 3,000 pcs

CARTON

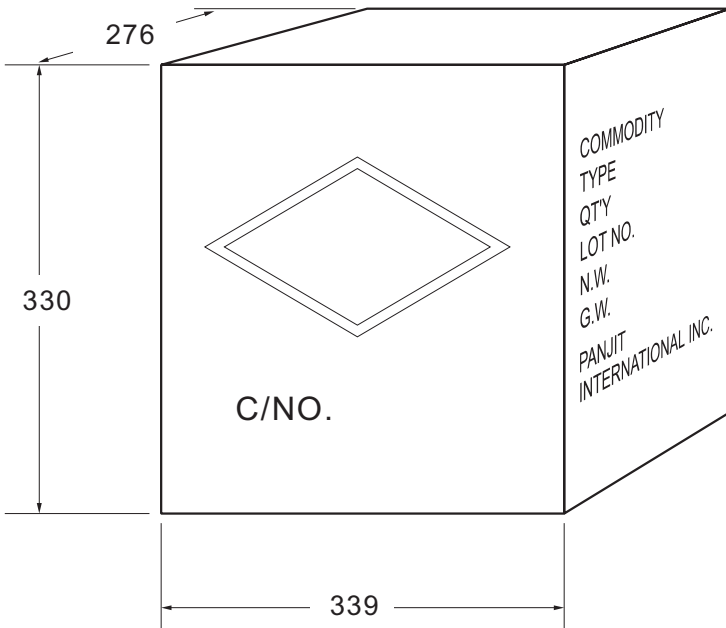

Box Dimensions : mm
Quantity per Box: 24,000 pcs

SHIPPING MARK

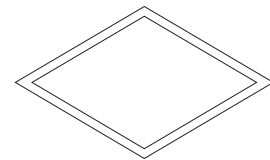

C/NO.
PRODUCT COUNTRY

SIDE MARK

COMMODITY:
TYPE:
Q'TY:
LOT NO.
N.W.
G.W.
PANJIT
INTERNATIONAL INC.



Bulk Packing

PACKAGE	INNER SIZE	BOX	CARTON SIZE	CARTON	APPROX. GROSS WEIGHT
	(m/m)	(EA)	(m/m)	(EA)	(Kg)
Bulk Packing					
A-405	198 x 84 x 20	1,000	459 x 214 x 256	50,000	12.7
AG / RB-10 (WOB)	258 x 190 x 77	1,000	395 x 270 x 400	10,000	15
AM	258 x 190 x 77	1,000	395 x 270 x 400	10,000	15
CM / KBPC	193 x 193 x 46	50	405 x 210 x 265	500	17
CMW / KBPC-W	193 x 193 x 46	50	405 x 210 x 265	500	17
KBPC-P /CP	193 x 193 x 46	50	405 x 210 x 265	500	9.5
KBPC-PW /CPW	193 x 193 x 46	50	405 x 210 x 265	500	9.5
CP-3 / 6 (K-3 / K-6)	219 x 115 x 90	200	600 x 235 x 198	2,000	7.3/8.8
CP-8 / 10 (K-8)	219 x 115 x 90	200	600 x 235 x 198	2,000	13.8
DIP	-	-	459 x 214 x 256	12,000	6.5
DO-15	200 x 85 x 25	1,000	459 x 214 x 256	40,000	20.7
DO-201AD	200 x 85 x 40	500	459 x 214 x 256	12,500	16
DO-201AE	200 x 85 x 40	500	459 x 214 x 256	12,500	16
DO-34	240 x 100 x 90	2,000	406 x 335 x 257	120,000	14.5
DO-35	240 x 100 x 90	2,000	406 x 335 x 257	120,000	17.1
DO-41	198 x 84 x 20	1,000	459 x 214 x 265	50,000	19.3
DO-41G	240 x 100 x 90	1,000	406 x 335 x 257	60,000	18.5
FL	230 x 230 x 50	500	495 x 245 x 180	3,000	18.4
GBJ (TUBE)	556 x 150 x 100	800	578 x 340 x 235	3,200	25.5
GBJ (BOX)	350 x 337 x 44	600	375 x 360 x 213	2,400	14.3
GBL	350 x 337 x 44	960	375 x 360 x 213	3,840	13.1
GBP	350 x 337 x 44	1,120	375 x 360 x 213	4,480	10.6
GBPC	193 x 193 x 46	50	405 x 210 x 265	500	17
GBPCW	193 x 193 x 46	50	405 x 210 x 265	500	17
GBU (TUBE)	488 x 150 x 100	800	510 x 310 x 235	3,200	22.6
GBU (BOX)	350 x 337 x 44	800	375 x 360 x 213	3,200	15.2
KBJ	220 x 176 x 45	200	375 x 230 x 260	2,000	15
KBPF	242 x 208 x 35	500	426 x 252 x 365	10,000	19.2
KBU	276 x 158 x 59	200	493 x 287 x 320	3,000	24
P-600	208 x 90 x 83	500	459 x 214 x 256	5,000	11.3
R-1	198 x 84 x 20	1,000	459 x 214 x 256	50,000	12.7
TO-220	540 x 145 x 85	2,000	555 x 306 x 200	8,000	20.5
ITO-220	540 x 145 x 85	2,000	555 x 306 x 200	8,000	22.9
TO-251AB	555 x 145 x 85	8,400	555 x 306 x 200	33,600	22
TO-3P / TO-247AD	-	-	536 x 243 x 100	1,500	13.9
TO-3PS / TO-247S	-	-	511 x 243 x 107	1,500	12.2



Reel Packing

PACKAGE	REEL SIZE	REEL	COMPONENT SPACE	TAPE SPACE	REEL DIA	CARTON SIZE	CARTON	APPROX. GROSS WEIGHT
	(inch)	(pcs)	(m/m)	(m/m)	(m/m)	(m/m)	(EA)	(Kg)
Reel Packing								
R-1	-	5,000	5.0	52	330	340 x 340 x 410	25,000	7.8
A-405	-	5,000	5.0	52	330	340 x 340 x 410	25,000	11
DO-15	-	4,000	5.0	52	330	340 x 340 x 410	20,000	11.4
DO-201AD	-	1,250	10.0	52	330	340 x 340 x 410	6,250	9.2
DO-201AE	-	1,250	10.0	52	330	340 x 340 x 410	6,250	9.2
DO-34	15	10,000	5.0	52	360	360 x 360 x 395	50,000	10.1
DO-35	15	10,000	5.0	52	360	360 x 360 x 395	50,000	11.2
DO-41	-	5,000	5.0	52	330	340 x 340 x 410	25,000	11.8
DO-41G	15	5,000	5.0	52	360	360 x 360 x 395	25,000	10.9
P-600	-	800	10.0	52	330	340 x 340 x 410	4,000	9.8
DPAK/TO-252	13	3,000	8.0	16	330	375 x 360 x 390	42,000	18.8
D2PAK/TO-263	13	800	16.0	24	330	375 x 360 x 390	6,400	14.4
MDI	13	3,000	8.0	12	330	375 x 360 x 390	48,000	14.7
SDIP	13	1,500	12.0	16	330	375 x 360 x 390	21,000	14.3
QUADRO-MELF	13	10,000	4.0	-	330	360 x 360 x 395	200,000	14.9
QUADRO-MELF	7	2,500	4.0	-	178	385 x 380 x 260	200,000	13.3
MELF/DL-41	13	5,000	4.0	-	330	360 x 360 x 395	100,000	23.5
MELF/DL-41	7	1,500	4.0	-	178	385 x 380 x 260	84,000	18.3
MICRO-MELF	13	10,000	4.0	-	330	360 x 360 x 395	200,000	11.5
MICRO-MELF	7	2,500	4.0	-	178	385 x 380 x 260	200,000	9.3
MINI-MELF	13	10,000	4.0	-	330	360 x 360 x 395	200,000	14.6
MINI-MELF	7	2500	4.0	-	178	385 x 380 x 260	200,000	12.7
SMA	13	7,500	4.0	12	330	375 x 360 x 390	120,000	17.3
SMA	7	1,800	4.0	12	178	390 x 240 x 420	72,000	10
SMB	13	3,000	8.0	12	330	375 x 360 x 390	48,000	13.2
SMB	7	500	8.0	12	178	390 x 240 x 420	20,000	6.5
SMC	13	3,000	8.0	16	330	375 x 360 x 390	42,000	18
SMC	7	500	8.0	16	178	390 x 240 x 420	15,000	8.3
SOD-123	13	10,000	4.0	8	330	375 x 360 x 213	120,000	6.5
SOD-123	7	3,000	4.0	8	178	390 x 270 x 400	240,000	9.9
SOD-123FL	13	10,000	4.0	8	330	375 x 360 x 213	120,000	7.2
SOD-123FL	7	3,000	4.0	8	178	390 x 270 x 400	240,000	10.6



Reel Packing

PACKAGE	REEL SIZE	REEL	COMPONENT SPACE	TAPE SPACE	REEL DIA	CARTON SIZE	CARTON	APPROX. GROSS WEIGHT
	(inch)	(pcs)	(m/m)	(m/m)	(m/m)	(m/m)	(EA)	(Kg)
Reel Packing								
SOD-323	13	12,000	4.0	8	330	375 x 360 x 213	144,000	5.9
SOD-323	7	5,000	4.0	8	178	390 x 270 x 400	400,000	9.4
SOD-523	13	12,000	4.0	8	330	375 x 360 x 213	144,000	5.4
SOD-523	7	5,000	4.0	8	178	390 x 270 x 400	400,000	9.1
SOD-723	7	8,000	2.0	8	178	390 x 270 x 400	640,000	8.5
SOD-923	7	8,000	2.0	8	178	390 x 270 x 400	640,000	7.7
SOT-23	13	12,000	4.0	8	330	375 x 360 x 213	144,000	7
SOT-23	7	3,000	4.0	8	178	390 x 270 x 400	240,000	8.3
SOT-323	13	12,000	4.0	8	330	375 x 360 x 213	144,000	6.1
SOT-323	7	3,000	4.0	8	178	390 x 270 x 400	240,000	7.9
SOT-363	13	10,000	4.0	8	330	375 x 360 x 213	120,000	7.1
SOT-363	7	3,000	4.0	8	178	390 x 270 x 400	240,000	10.2
SOT-23 (ESD)	7	3,000	4.0	8	178	455 x 270 x 440	240,000	9.5
SOT-323 (ESD)	7	3,000	4.0	8	178	455 x 270 x 440	240,000	9.1
SOT-363 (ESD)	7	3,000	4.0	8	178	455 x 270 x 440	240,000	10
SOT-353	13	10,000	4.0	8	330	375 x 360 x 213	120,000	7.2
SOT-353	7	3,000	4.0	8	178	390 x 270 x 400	240,000	10
SOT-553	13	10,000	4.0	8	330	375 x 360 x 213	120,000	5.2
SOT-553	7	4,000	4.0	8	178	390 x 270 x 400	320,000	9.4
SOT-563	13	10,000	4.0	8	330	375 x 360 x 213	120,000	5.2
SOT-563	7	4,000	4.0	8	178	390 x 270 x 400	320,000	9.4
SOT23-5L	13	10,000	4.0	8	330	375 x 360 x 213	120,000	7.9
SOT23-5L	7	3,000	4.0	8	178	390 x 270 x 400	240,000	14.5
SOT23-6L	13	10,000	4.0	8	330	375 x 360 x 213	120,000	7.9
SOT23-6L	7	3,000	4.0	8	178	390 x 270 x 400	240,000	14.5
SOT-143	13	10,000	4.0	8	330	375 x 360 x 213	120,000	7
SOT-143	7	3,000	4.0	8	178	390 x 270 x 400	240,000	12.8
SOIC-08	13	3,000	8.0	12	330	375 x 360 x 213	48,000	14.2
QFN 1.2 x 1.5	7	3,000	4.0	8	178	390 x 270 x 400	240,000	7.1
QFN 1.6 x 1.6	7	4,000	4.0	8	178	390 x 240 x 420	200,000	7.8
QFN 2.0 x 2.0	7	3,000	4.0	8	178	390 x 270 x 400	240,000	7.1



Ammunition Packing

PACKAGE	AMMO	COMPONENT SPACE	TAPE SPACE	BOX SIZE	CARTON	CARTON	APPROX. GROSS WEIGHT
	(PCS)	(m/m)	(m/m)	(m/m)	(m/m)	(E/A)	(Kg)
Ammunition Packing							
A-405	5,000	5	26	255 x 47 x 150	339 x 276 x 330	60,000	12.4
A-405	5,000	5	52	255 x 75 x 150	339 x 276 x 330	40,000	16
DO-15	3,000	5	52	255 x 75 x 150	339 x 276 x 330	24,000	13.3
DO-201AD	1,250	10	52	255 x 47 x 122	339 x 276 x 330	10,000	13.4
DO-201AE	1,250	10	52	255 x 47 x 122	339 x 276 x 330	10,000	13.4
DO-34	5,000	5	26	248 x 80 x 48	406 x 335 x 257	150,000	14.6
DO-34	5,000	5	52	248 x 80 x 75	406 x 335 x 257	100,000	12.7
DO-35	5,000	5	26	248 x 80 x 48	406 x 335 x 257	150,000	16.7
DO-35	5,000	5	52	248 x 80 x 75	406 x 335 x 257	100,000	15.2
DO-41	5,000	5	52	255 x 75 x 150	339 x 276 x 330	40,000	16
DO-41G	2,500	5	26	248 x 80 x 48	406 x 335 x 257	75,000	17.1
DO-41G	2,500	5	52	248 x 80 x 75	406 x 335 x 257	50,000	15.7
P-600	400	10	52	255 x 47 x 122	339 x 276 x 330	3,200	8.1
R-1	3,000	5	26	255 x 47 x 73	310 x 268 x 170	36,000	6.3
R-1	3,000	5	52	256 x 73 x 73	310 x 268 x 170	24,000	6.4
R-1	5,000	5	52	255 x 73 x 122	339 x 276 x 274	40,000	10.3



5. HIGH RELIABILITY TESTING SPEC.

NO	TEST ITEM	TEST CONDITION	REFERENCE DOCUMENT	LOT QUALITY LEVEL	REMARK
1	TEMPERATURE CYCLING (T.C.T)	Ta = -55 + 0, -3 °C 10min Ta = + 175 +/- °C 10min FOR 20 CYCLE	MIL - STD - 750D METHOD - 1051.5	LTPD 10 S.s. = 22 ACCEPT FOR 0 FAILURE ONLY.	
2	HIGH TEMPERATURE STORAGE LIFE (H.T.S.L)	Ta = 125 +/- 5 °C TESTING TIME: 168 HRS 500 HRS	MIL-STD-750D METHOD-1031.2	LTPD10 S.s. = 22 ACCEPT FOR 0 FAILURE ONLY.	
3	SOLDERABILITY TEST	TEMPERATURE OF SOLDER POT = 245 +/- 5 °C TIME FOR DIPPING FLUX = 5 -10 SEC TIME FOR DIPPING IN SOLDER = 5 +/- 0.5 SEC DIPPING DEPTH = 0.05 inch max FOR ONE CYCLE	MIL-STD-750D	METHOD-2026.10 LTPD 7 S.s. = 32 ACCEPT FOR 0 FAILURE ONLY.	
4	HIGH TEMPERATURE REVERSE BIAS (H.T.R.B)	Ta = 150 +/- 5 °C VR = 80 % VR (CUSTOM SECP) TESTING TIME: 168 HRS 500 HRS	MIL-STD-750D METHOD-1038.3	LTPD10 S.s. = 22 ACCEPT FOR 0 FAILURE ONLY.	
5	CONTINUE FORWARD OPERATING LIFE (C.F.O.L)	Ta = 55 °C I = IO +/- 10 % TESTING TIME: 168 HRS 500 HRS	MIL-STD-750D METHOD-1027.3	LTPD10 S.s. = 22 ACCEPT FOR 0 FAILURE ONLY.	
6	THERMAL SHOCK (T.S.T)	HOT TANK T = 100 °C + 10 / -2 °C t = 5 min COLD TANK T = 0 °C + 2 / -10 °C t = 5 min 15 CYCLE TIME BETWEEN TRANSFERRING DO NOT EXCEED 10 SECOND.	MIL-STD-750D METHOD-1056.7	LTPD10 S.s. = 22 ACCEPT FOR 0 FAILURE ONLY.	
7	PRESSURE COOKER (P.C.T)	Ta = 121 °C P = 1.2 kg / cm ² TIME = 96 HRS	JEDEC JESD22-A102-C	LTPD10 S.s. = 22 ACCEPT FOR 0 FAILURE ONLY.	
8	INTERMITTENT FORWARD OPERATING LIFE (I.F.O.L)	I = Io x 1.0 POWER ON : 30 SEC POWER OFF : 50 SEC TESTING TIME: 2000 CYCLES	MIL-STD-750D METHOD 1036.3	LTPD10 S.s. = 22 ACCEPT FOR 0 FAILURE ONLY.	
9	FORWARD SURGE CURRENT (I.F.S.M)	SQ WAVE OR SINE WAVE IFSM=DATE SHEET SPEC. TIME = 8.3 Msec T = 1 CYCLE	MIL-STD-750D METHOD 4066.3	LTPD10 S.s. = 22 ACCEPT FOR 0 FAILURE ONLY.	
10	HUMIDITY	Ta = 85 °C RH = 85 % TESTING TIME: 168 HRS 500 HRS	MIL-STD-750D METHOD 1021.1	LTPD10 S.s. = 22 ACCEPT FOR 0 FAILURE ONLY.	
11	SOLDERABILITY RESISTANCE	TEMPERATURE OF SOLDER POT = 260 +/- 5 °C TIME FOR DIPPING IN SOLDER = 10 + 2 / -0 SEC DIPPING DEPTH = 1.57 +/- 0.79 mm BELOW BODY FOR ONE CYCLE	MIL-STD-750D METHOD 2031.1	LTPD10 S.s. = 22 ACCEPT FOR 0 FAILURE ONLY.	
SCHOTTKY PRODUCT TESTING TEMPERATURE 100 °C +/- 5°C MAX(NORMAL)					