



TABLE OF CONTENTS

1.DATA SHEET PAGE 1

2.MARKING PAGE 6

3.TAPING PAGE 7

4.PACKING PAGE 8

5.HIGH RELIABILITY SPEC PAGE 12



1.DATA SHEET

MMSZ5221BS SERIES

SURFACE MOUNT SILICON ZENER DIODES

VOLTAGE 2.4 to 39 Volts

POWER 200 mWatts

SOD-323

Unit: inch (mm)

FEATURES

- Planar Die construction
- 200mW Power Dissipation
- Ideally Suited for Automated Assembly Processes
- Pb free product are available : 99% Sn above can meet RoHS environment substance directive request

MECHANICAL DATA

- Case: SOD-323, Molded Plastic
- Terminals: Solderable per MIL-STD-750, Method 2026
- Polarity: See Diagram Below
- Approx. Weight: 0.008 grams
- Mounting Position: Any

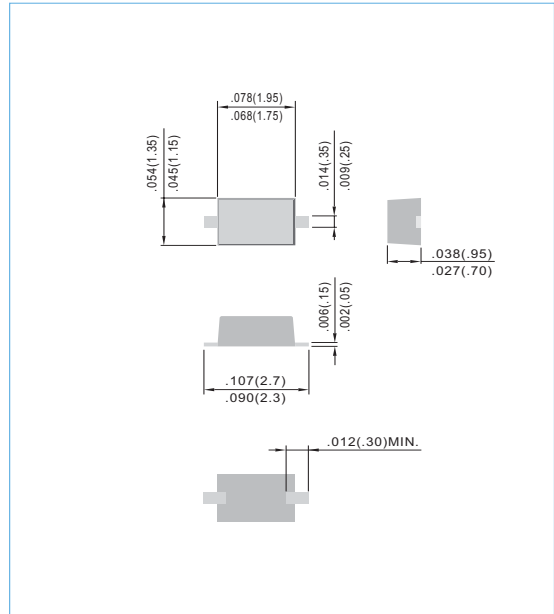

MAXIMUM RATINGS AND ELECTRICAL CHARACTERISTICS

Parameter	Symbol	Value	Units
Maximum Forward Voltage Drop at IF=100mA	V _F	1.0	V
Maximum Power Dissipation (Notes A) at 25°C	P _D	200	mW
Peak Forward Surge Current, 8.3ms single half sine-wave superimposed on rated load (JEDEC method) (Notes B)	I _{FSM}	4.0	Amps
Operating Junction and Storage Temperature Range	T _J	-55 to +150	°C

NOTES:

A. Mounted on 5.0mm²(.013mm thick) land areas.

B. Measured on 8.3ms, single half sine-wave or equivalent square wave, duty cycle = 4 pulses per minute maximum.



Part Number	Marking Code	Nominal Zener Voltage			Max. Zener Impedance				Max Reverse Leakage Current	
		V _Z @ I _{ZT}			Z _{VT} @ I _{ZT}		Z _{VK} @ I _{ZK}		I _R @ V _R	
		Nom. V	Min. V	Max. V	Ω	mA	Ω	mA	μA	V
200 mWatts Zener Diodes										
MMSZ5221BS	C1	2.4	2.28	2.52	30	20.0	1200	0.25	100	1.0
MMSZ5222BS	C2	2.5	2.38	2.63	30	20.0	1250	0.25	100	1.0
MMSZ5223BS	C3	2.7	2.57	2.84	30	20.0	1300	0.25	75	1.0
MMSZ5225BS	C5	3	2.85	3.15	30	20.0	1600	0.25	50	1.0
MMSZ5226BS	D1	3.3	3.14	3.47	28	20.0	1600	0.25	25	1.0
MMSZ5227BS	D2	3.6	3.42	3.78	24	20.0	1700	0.25	15	1.0
MMSZ5228BS	D3	3.9	3.71	4.10	23	20.0	1900	0.25	10	1.0
MMSZ5229BS	D4	4.3	4.09	4.52	22	20.0	2000	0.25	5.0	1.0
MMSZ5230BS	D5	4.7	4.47	4.94	19	20.0	1900	0.25	5.0	2.0
MMSZ5231BS	E1	5.1	4.85	5.36	17	20.0	1600	0.25	5.0	2.0
MMSZ5232BS	E2	5.6	5.32	5.88	11	20.0	1600	0.25	5.0	3.0
MMSZ5234BS	E4	6.2	5.89	6.51	7	20.0	1000	0.25	5.0	4.0
MMSZ5235BS	E5	6.8	6.46	7.14	5	20.0	750	0.25	3.0	5.0
MMSZ5236BS	F1	7.5	7.13	7.88	6	20.0	500	0.25	3.0	6.0
MMSZ5237BS	F2	8.2	7.79	8.61	8	20.0	500	0.25	3.0	6.0
MMSZ5239BS	F4	9.1	8.65	9.56	10	20.0	600	0.25	3.0	6.5
MMSZ5240BS	F5	10	9.50	10.50	17	20.0	600	0.25	3.0	8.0
MMSZ5241BS	H1	11	10.45	11.55	22	20.0	600	0.25	3.0	8.4
MMSZ5242BS	H2	12	11.40	12.60	30	20.0	600	0.25	2.0	9.1
MMSZ5243BS	H3	13	12.35	13.65	13	9.5	600	0.25	1.0	9.9
MMSZ5245BS	H5	15	14.25	15.75	16	8.5	600	0.25	0.5	11.0
MMSZ5246BS	J1	16	15.20	16.80	17	7.8	600	0.25	0.1	12.0
MMSZ5248BS	J3	18	17.10	18.90	21	7.0	600	0.25	0.1	14.0
MMSZ5250BS	J5	20	19.00	21.00	25	6.2	600	0.25	0.1	15.0
MMSZ5251BS	K1	22	20.90	23.10	29	5.6	600	0.25	0.1	17.0
MMSZ5252BS	K2	24	22.80	25.20	33	5.2	600	0.25	0.1	18.0
MMSZ5254BS	K4	27	25.65	28.35	41	5.0	600	0.25	0.1	21.0
MMSZ5255BS	K5	28	26.60	29.40	44	4.5	600	0.25	0.1	21.0
MMSZ5256BS	M1	30	28.50	31.50	49	4.2	600	0.25	0.1	23.0
MMSZ5257BS	M2	33	31.35	34.65	58	3.8	700	0.25	0.1	25.0
MMSZ5258BS	M3	36	34.20	37.80	70	3.4	700	0.25	0.1	27.0
MMSZ5259BS	M4	39	37.05	40.95	80	3.2	800	0.25	0.1	30.0

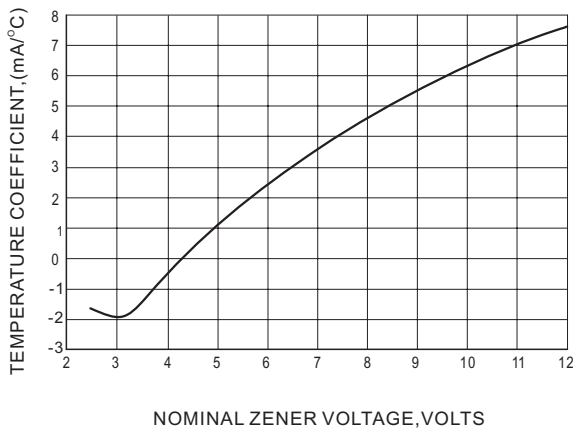

Fig. 1 TEMPERATURE COEFFICIENTS

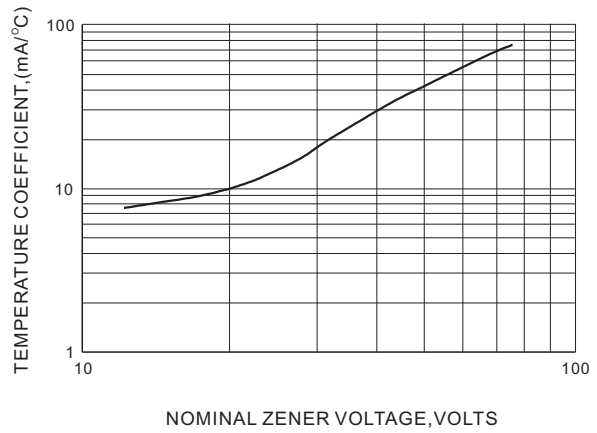

Fig. 2 TEMPERATURE COEFFICIENTS

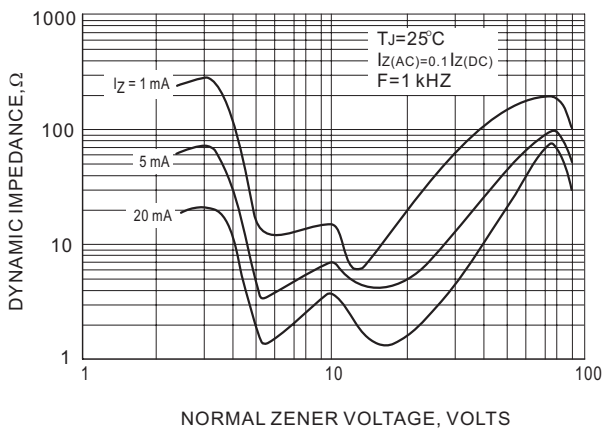

Fig. 3 EFFECT OF ZENER VOLTAGE ON ZENER IMPEDANCE

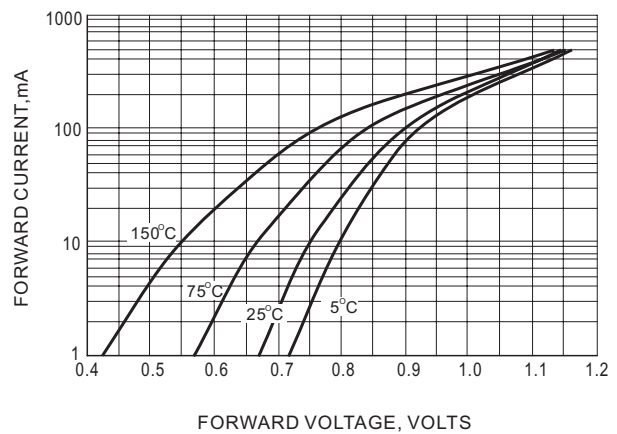

Fig. 4 TYPICAL FORWARD VOLTAGE

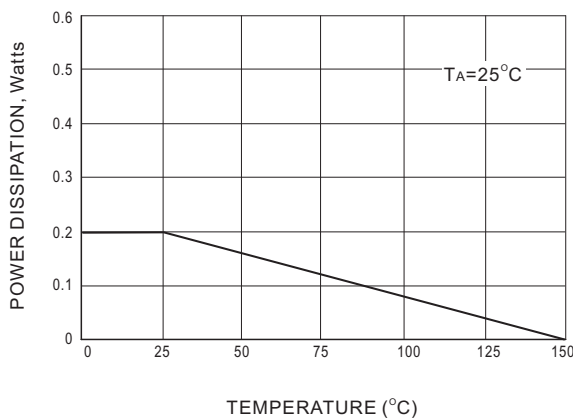

Fig. 5 STEADY STATE POWER DERATING

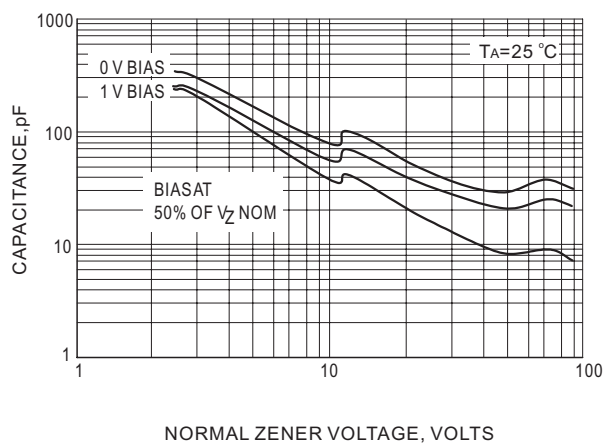

Fig. 6 TYPICAL CAPACITANCE

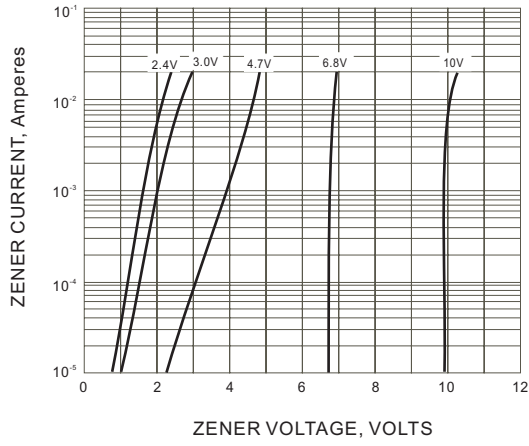

Fig.7 ZENER VOLTAGE VERSUS ZENER CURRENT

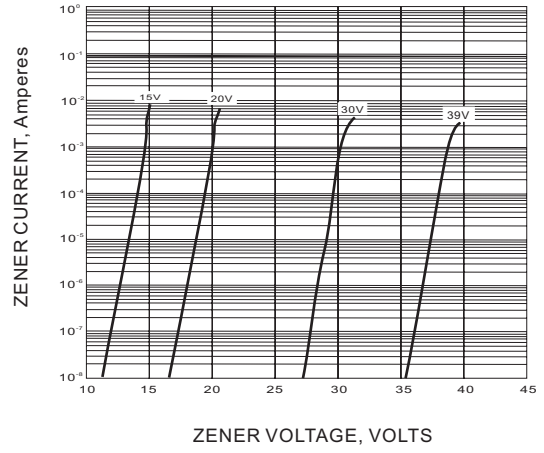

Fig.8 ZENER VOLTAGE VERSUS ZENER CURRENT

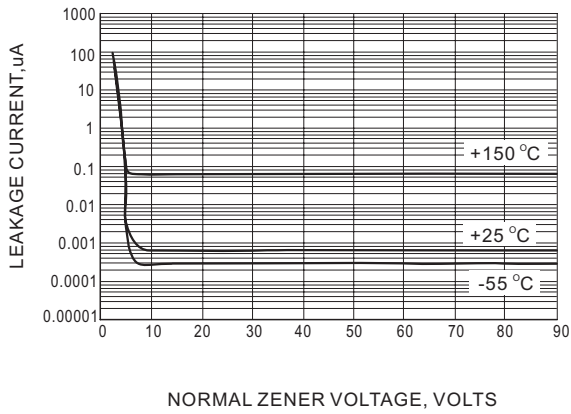
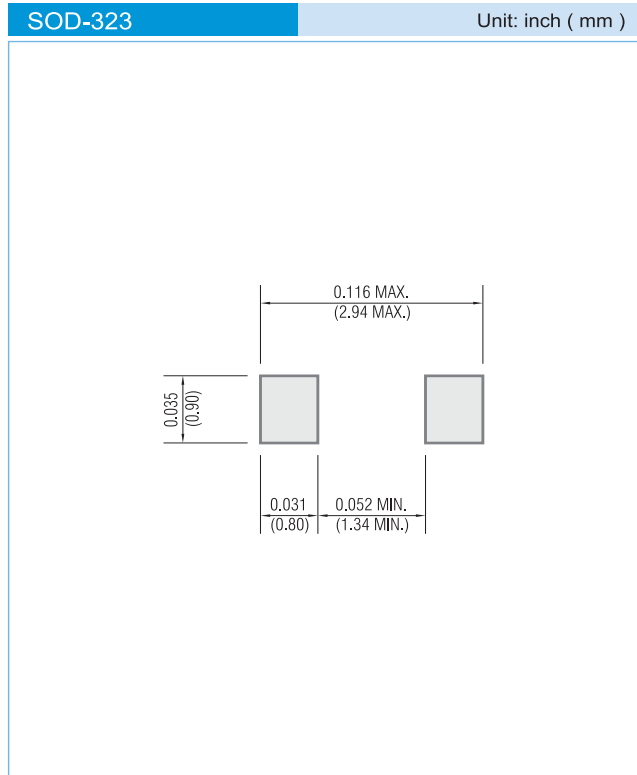

Fig.9 TYPICAL LEAKAGE CURRENT



MOUNTING PAD LAYOUT



ORDER INFORMATION

- Packing information
 - T/R - 12K per 13" plastic Reel
 - T/R - 5K per 7" plastic Reel

LEGAL STATEMENT

IMPORTANT NOTICE

This information is intended to unambiguously characterize the product in order to facilitate the customer's evaluation of the device in the application. The information will help the customer's technical experts determine that the device is compatible and interchangeable with similar devices made by other vendors. The information in this data sheet is believed to be reliable and accurate. The specifications and information herein are subject to change without notice. New products and improvements in products and product characterization are constantly in process. Therefore, the factory should be consulted for the most recent information and for any special characteristics not described or specified.

Copyright Pan Jit International Inc. 2003

All rights reserved. Reproduction in whole or in part is prohibited without the prior written consent of the copyright owner.

The information presented in this document does not form part of any quotation or contract. The information presented is believed to be accurate and reliable, and may change without notice in advance. No liability will be accepted by the publisher for any consequence of use. Publication thereof does not convey nor imply any license under patent or other industrial or intellectual property rights.



2.MARKING

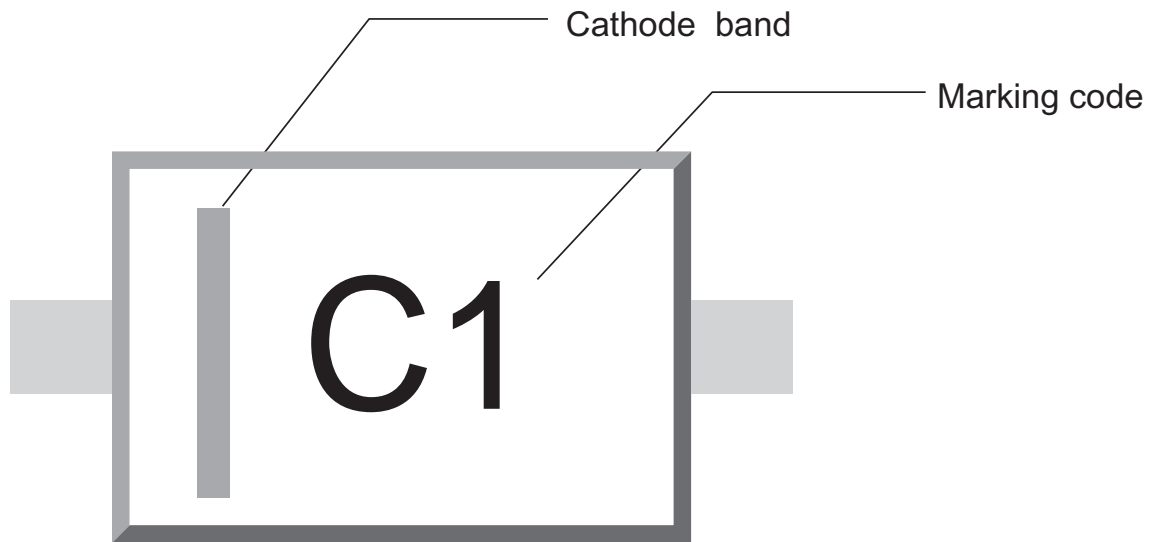



3. TAPING

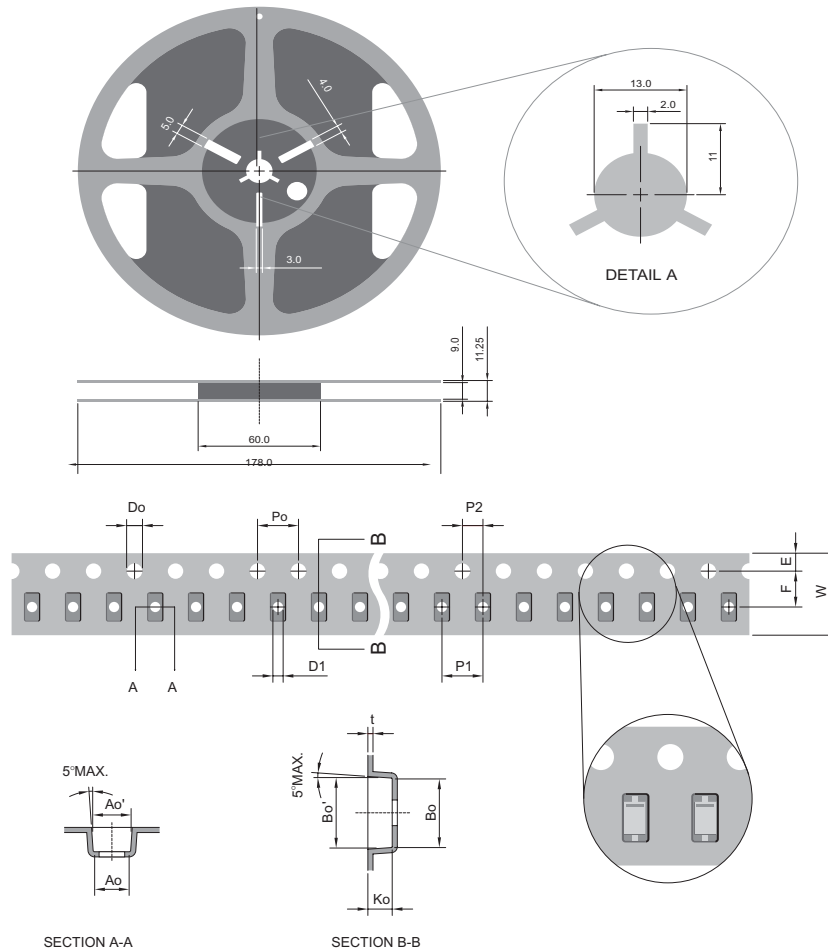

SYMBOL	mm (INCH)
TYPE SIZE 8.00 (0.314)	
Ao	1.50 ± 0.10(0.054 ± 0.004)
Bo	2.75 ± 0.10(0.141 ± 0.004)
Do	1.55 ± 0.10(0.061 ± 0.004)
D	560.05
D1	76.30 ± 0.05(3.799 ± 0.002)
E	1.75 ± 0.10(0.069 ± 0.004)
F	3.50 ± 0.05(0.137 ± 0.002)
Ko	0.95 ± 0.10(0.037 ± 0.004)
Po	4.00 ± 0.10(0.157 ± 0.004)
P1	4.00 ± 0.10(0.157 ± 0.004)
P2	2.00 ± 0.05(0.009 ± 0.002)
t	0.20 ± 0.05(0.009 ± 0.002)
W	8.00 ± 0.30(0.314 ± 0.012)
Ao'	1.35 ± 0.15(0.053 ± 0.006)
Bo'	2.65 ± 0.15(0.104 ± 0.006S)

- NOTE:
1. There shall be leader of 230 mm minimum which may consist of carrier and or cover tape follower by a minimum of 160 mm of carrier tape sealed with cover tape.
 2. There shall be minimum of 160 mm of empty component pockets sealed with cover tape.
 3. Devices are packed in accordance with EIA standard EIA-481-A and specifications given above.



4. PACKING

REEL PACKING

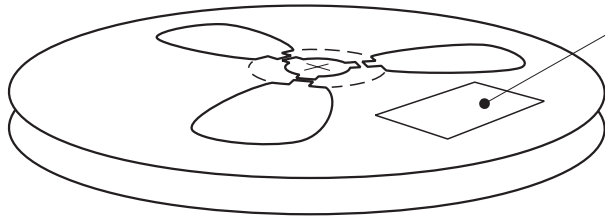

Quantity per Reel: 5,000 pcs

LABEL TYPE

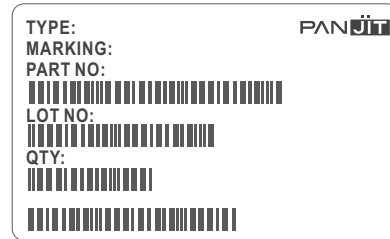

CARTON

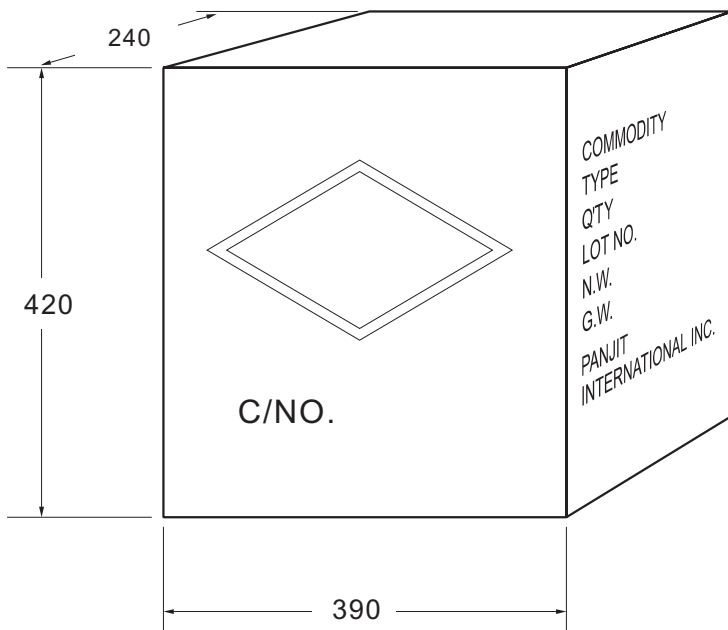

Box Dimensions : mm
Quantity per Box: 250,000pcs

SHIPPING MARK

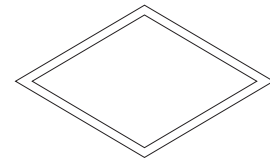

C/NO.
PRODUCT COUNTRY

SIDE MARK

COMMODITY:
TYPE:
Q'TY:
LOT NO.
N.W.
G.W.
PANJIT
INTERNATIONAL INC.



Bulk Packing

PACKAGE	INNER SIZE	BOX	CARTON SIZE	CARTON	APPROX. GROSS WEIGHT
	(m/m)	(EA)	(m/m)	(EA)	(Kg)
Bulk Packing					
A-405	198 x 84 x 20	10,000	459 x 214 x 256	50,000	18.2
AM	260 x 190 x 80	1,000	400 x 273 x 415	10,000	15
CM / W	195 x 195 x 40	50	460 x 215 x 260	500	18
CP-15 / 25 / 35	195 x 195 x 40	50	460 x 215 x 260	500	11
CP-3 / 6	260 x 190 x 80	400	400 x 273 x 415	4,000	8.5
CP-8 / 10	260 x 190 x 80	250	400 x 273 x 415	2,500	14
DIP	-	-	495 x 214 x 256	12,000	8.8
DO-15	200 x 85 x 25	1,000	459 x 214 x 256	40,000	17
DO-201AD	200 x 85 x 40	500	495 x 214 x 256	12,500	15.8
DO-201AE	200 x 85 x 40	500	495 x 214 x 256	12,500	15.8
DO-34	96 x 80 x 42	2,000	410 x 335 x 265	120,000	12
DO-35	96 x 80 x 42	2,000	410 x 335 x 265	120,000	13.8
DO-41	240 x 100 x 90	5,000	410 x 335 x 265	60,000	20
DO-41G	96 x 80 x 42	1,000	410 x 335 x 265	60,000	20
FI	208 x 90 x 83	500	490 x 225 x 380	10,000	20.4
FL	270 x 225 x 50	500	463 x 283 x 185	3,000	18.2
GBJ	352 x 337 x 44	800	375 x 360 x 213	3,200	25.4
GBL	350 x 337 x 44	960	375 x 360 x 213	3,840	13.1
GBP	350 x 337 x 44	1,120	375 x 360 x 213	4,480	10.7
GBPC	195 x 195 x 40	50	460 x 215 x 260	500	12
GBPCW	195 x 195 x 40	50	460 x 215 x 260	500	18
GBU	350 x 337 x 44	800	375 x 360 x 213	3,200	17
GL	195 x 195 x 40	80	460 x 215 x 260	800	11
GPJ	500 x 150 x 145	750	572 x 306 x 218	1,500	17
KBJ	219 x 177 x 44	200	367 x 232 x 250	2,000	16.3
KBPC / W	195 x 195 x 40	50	460 x 215 x 260	500	18
KBPM	490 x 150 x 110	1,200	510 x 335 x 240	4,800	19
KBU	270 x 225 x 50	200	463 x 283 x 185	1,200	10
MDI	350 x 337 x 44	6,000	375 x 360 x 390	48,000	14.4
P-600	208 x 90 x 83	500	495 x 214 x 256	5,000	11.9
R-1	198 x 84 x 20	1,000	495 x 214 x 256	50,000	18.2
SDIP	-	-	495 x 214 x 256	24,000	16.8
TO / ITO-220	555 x 145 x 95	2,000	572 x 306 x 218	8,000	19
TO-251AB	560 x 210 x 79	8,400	572 x 306 x 218	33,600	22
TO-247AD	-	-	536 x 243 x 100	1,500	13.2
RB/WOB	258x190x77	1,000	395x270x400	10,000	15.0/17.0
KBP	258x190x77	1,000	395x270x400	10,000	18.0
KBL	230x147x50	200	460x245x275	3,000	17.25
K3/K6	210x115x90	200	600x235x198	2,000	7.3/8.8
K8	210x115x90	200	600x235x198	2,000	13.8
K10/K15/K25/K35/K50M	193x193x46	50	405x210x265	500	17.0
K10/K15/K25/K35/K50P	193x193x46	50	405x210x265	500	12.0
K10/K15/K25/K35/K50W	193x193x46	50	405x210x265	500	17.0



Reel Packing

PACKAGE	REEL	COMPONENT SPACE	TAPE SPACE	REEL DIA	CARTON SIZE	CARTON	APPROX. GROSS WEIGHT
	(pcs)	(m/m)	(m/m)	(m/m)	(m/m)	(EA)	(Kg)
Reel Packing							
A-405	5,000	5.0	52	330	340 x 340 x 410	25,000	11.3
TO-263	2,500	8.0	24	330	375 x360 x 390	35,000	18
DO-15	4,000	5.0	52	330	340 x 340 x 410	20,000	11
DO-201AD	1,250	10.0	52	330	340 x 340 x 410	6,250	9.2
DO-201AE	1,250	10.0	52	330	340 x 340 x 410	6,250	9.2
DO-34	10,000	5.0	52	360	360 x 360 x 395	50,000	9.5
DO-35	10,000	5.0	52	360	360 x 360 x 395	50,000	12
DO-41	5,000	5.0	52	330	360 x 360 x 395	25,000	13
DO-41G	5,000	5.0	52	360	360 x 360 x 395	25,000	13
TO-252	800	16.0	16	330	350 x 337 x 44	6,400	15
MDI	3,000	8.0	12	330	375 x360 x 390	48,000	14.4
MELF/DL-41	5,000	4.0	-	330	350 x 350 x 300	100,000	14
MICRO-MELF	2,500	4.0	-	178	385 x 380 x 260	200,000	13.5
MINI-MELF	10,000 / 2,500	4.0	-	330 / 178	360 x 360 x 395 / 385 x 380 x 260	200,000 / 120,000	14.0 / 13.5
P-600	800	10.0	52	330	340 x 340 x 410	4,000	11
QFN 1.6 x 1.6	4,000	4.0	8	178	390 x 240 x 420	200,000	7.8
R-1	5,000	5.0	52	330	340 x 340 x 410	25,000	6.3
SDIP	1,500	12.0	16	330	375 x360 x 390	21,000	16.3
SMA	7,500 / 1,800	4.0	12	330 / 178	375 x360 x 390 / 390 x 240 x 420	120,000 / 72,000	17.5 / 10
SMB	3,000 / 500	4.0	12	330 / 178	375 x360 x 390 / 390 x 240 x 420	48,000 / 20,000	13.6 / 7.5
SMC	3,000 / 500	12.0	16	330 / 178	375 x360 x 390 / 390 x 240 x 420	42,000 / 15,000	6.2 / 7.3
SOD-123	10,000 / 3,000	4.0	8	330 / 178	375 x 360 x 213 / 390 x 240 x 420	120,000 / 150,000	6.4
SOD-123FL	10,000 / 3,000	4.0	8	330 / 178	375 x 360 x 213 / 390 x 240 x 420	120,000 / 150,000	6.4
SOD-323	12,000 / 5,000	4.0	8	330 / 178	375 x 360 x 213 / 390 x 240 x 420	144,000 / 250,000	10
SOT-23	10,000 / 3,000	4.0	8	330 / 178	375 x 360 x 213 / 390 x 240 x 420	144,000 / 150,000	6.4
SOT-323	10,000 / 3,000	4.0	8	330 / 178	375 x 360 x 213 / 390 x 240 x 420	144,000 / 150,000	6.4
SOT-363	10,000 / 3,000	4.0	8	330 / 178	735 x 365 x 292 / 390 x 240 x 420	300,000 / 150,000	15.66 / 7.0
SOT-353	10,000 / 3,000	4.0	8	330 / 178	735 x 365 x 292 / 390 x 240 x 420	300,000 / 150,000	15.66 / 7.0
TO-92	2,000	-	-	335	390 x 390 x 280	8,000	6.067
SOD-523	12,000 / 5,000	4.0	8	330 / 178	375 x 360 x 213 / 390 x 240 x 420	144,000 / 250,000	10
QFN 2.0 x 2.0	5,000 / 3,000 / 1,000	4.0	8	330 / 178 / 178	553 x 365 x 358 / 333 x 240 x 257 / 333 x 240 x 257	45,000 / 39,000 / 13,000	4.5 / 3.0 / 2.5
SOT23-6L	3,000 / 2,500 / 1,000	4.0	8	330 / 178 / 178	553 x 365 x 358 / 333 x 240 x 257 / 333 x 240 x 257	39,000 / 32,500 / 13,000	3.0 / 3.0 / 2.5
SOIC-08	3,000 / 1,500 / 1,000	4.0	8	330 / 330 / 178	553 x 365 x 358 / 553 x 365 x 358 / 333 x 240 x 257	39,000 / 13,500 / 13,000	6.5 / 5.0 / 3.5



Ammunition Packing

PACKAGE	AMMO	COMPONENT SPACE	TAPE SPACE	BOX SIZE	CARTON SIZE	CARTON	APPROX. GROSS WEIGHT
	(pcs)	(m/m)	(m/m)	(m/m)	(m/m)	(EA)	(Kg)
Ammunition Packing							
A-405	5,000	5	26	255 x 50 x 150	399 x 276 x 330	60,000	16.0
A-405	5,000	5	52	255 x 75 x 150	399 x 276 x 330	40,000	16.0
DO-15	3,000	5	52	255 x 75 x 150	399 x 276 x 330	24,000	11.9
DO-201AD	1,250	10	52	255 x 75 x 150	399 x 276 x 330	10,000	14.0
DO-201AE	1,250	10	52	255 x 75 x 150	399 x 276 x 330	10,000	14.0
DO-34	5,000	5	26	248 x 80 x 48	410 x 335 x 265	150,000	15.5
DO-34	5,000	5	52	248 x 80 x 75	410 x 335 x 265	100,000	14.1
DO-35	5,000	5	26	248 x 80 x 48	410 x 335 x 265	150,000	20.0
DO-35	5,000	5	52	248 x 80 x 75	410 x 335 x 265	100,000	15.7
DO-41	5,000	5	52	255 x 75 x 150	399 x 276 x 330	40,000	19.1
DO-41G	2,500	5	26	248 x 80 x 48	410 x 335 x 265	75,000	21.5
DO-41G	2,500	5	52	248 x 80 x 75	410 x 335 x 265	50,000	19.0
P-600	400	10	52	255 x 75 x 150	399 x 276 x 330	3,200	9.0
R-1	5,000	5	26	255 x 50 x 150	399 x 276 x 330	40,000	16.0
R-1	5,000	5	52	255 x 75 x 150	399 x 276 x 330	40,000	16.0



5. HIGH RELIABILITY TESTING SPEC.

NO	TEST ITEM	TEST CONDITION	REFERENCE DOCUMENT	LOT QUALITY LEVEL	REMARK
1	TEMPERATURE CYCLING (T.C.T)	Ta= -55+0,-3°C 10min Ta= +150+/-°C 10min FOR 20 CYCLE	MIL - STD - 750D METHOD - 1051.5	LTPD 10 S.s.=22 ACCEPT FOR 0 FAILURE ONLY.	
2	HIGH TEMPERATURE STORAGE LIFE (H.T.S.L)	Ta=150 +/- 5°C TESTING TIME: 168HRS 250HRS 500HRS	MIL-STD-750D METHOD-1031.2	LTPD10 S.s.=22 ACCEPT FOR 0 FAILURE ONLY.	
3	SOLDERABILITY TEST	TEMPERATURE OF SOLDER POT=260 +/- 5 TIME FOR DIPPING FLUX=5-10SEC TIME FOR DIPPING IN SOLDER=5+/-0. 5SEC DIPPING DEPTH=0.05 inch max FOR ONE CYCLE	MIL-STD-750D	METHOD-2026.10 LTPD 7 S.s.=32 ACCEPT FOR 0 FAILURE ONLY.	
4	HIGH TEMPERATURE REVERSE BIAS (H.T.R.B)	Ta=150 +/- 5°C VR=80%VR(CUSTOM SECP) TESTING TIME: 48HRS 96HRS 168HRS 250HRS 500HRS	MIL-STD-750D METHOD-1038.3	LTPD10 S.s.=22 ACCEPT FOR 0 FAILURE ONLY.	
5	CONTINUE FORWARD OPERATING LIFE (C.F.O.L)	Ta=55 °C I=IO +/-10% TESTING TIME: 168HRS 250HRS 500HRS	MIL-STD-750D METHOD-1027.3	LTPD10 S.s.=22 ACCEPT FOR 0 FAILURE ONLY.	
6	THERMAL SHOCK (T.S.T)	HOT TANK T=100°C+10/-2°C t=5min COLD TANK T=0°C+2/-10°C t=5min 15 CYCLE TIME BETWEEN TRANSFERRING DO'NOT EXCEED 10 SECOND.	MIL-STD-750D METHOD-1056.7	LTPD10 S.s.=22 ACCEPT FOR 0 FAILURE ONLY.	
7	PRESSURE COOKER (P.C.T)	Ta=121°C P=1.2kg/cm ² TIME=96HRS	JEDEC JESD22-A102-C	LTPD10 S.s.=22 ACCEPT FOR 0 FAILURE ONLY.	
8	INTERMITTENT FORWARD OPERATING LIFE (I.F.O.L)	I = Io x 1.0 POWER ON : 30SEC POWER OFF : 50SEC TESTING TIME: 2000 CYCLES	MIL-STD-750D METHOD 1036.3	LTPD10 S.s.=22 ACCEPT FOR 0 FAILURE ONLY.	
9	FORWARD SURGE CURRENT (I.F.S.M)	SQ WAVE OR SINE WAVE IFSM=DATE SHEET SPEC. TIME=8.3Msec T=1 CYCLE	MIL-STD-750D METHOD 4066.3	LTPD10 S.s.=22 ACCEPT FOR 0 FAILURE ONLY.	
10	HUMIDITY	Ta=85°C RH=85% TESTING TIME: 168HRS 250HRS 500HRS	MIL-STD-750D METHOD 1021.1	LTPD10 S.s.=22 ACCEPT FOR 0 FAILURE ONLY.	
11	SOLDERABILITY RESISTANCE	TEMPERATURE OF SOLDER POT =260+/-5°C TIME FOR DIPPING IN SOLDER =10+2/-0 SEC DIPPING DEPTH=1.57+0.79 mm BELOW BODY FOR ONE CYCLE	MIL-STD-750D METHOD 2031.1	LTPD10 S.s.=22 ACCEPT FOR 0 FAILURE ONLY.	

SCHOTTKY PRODUCT TESTING TEMPERATURE 125 °C MAX(NORMAL)