



MMBD914TG

SURFACE MOUNT SWITCHING DIODES

VOLTAGE 100 Volts **POWER** 200mWatts

FEATURES

- Very Fast Reverse Recovery ($T_{rr} < 4.0$ ns typical)
- Low Capacitance (4pF@0V typical)
- Surface Mount Package Ideally Suited for Automatic insertion
- In compliance with EU RoHS 2002/95/EC directives

MECHANICAL DATA

- Case : SOD-723, Plastic
- Terminals : Solderable per MIL-STD-750, Method 2026
- Approx. Weight : 0.0007gram
- Marking : BF

SOD-723 Unit: inch (mm)

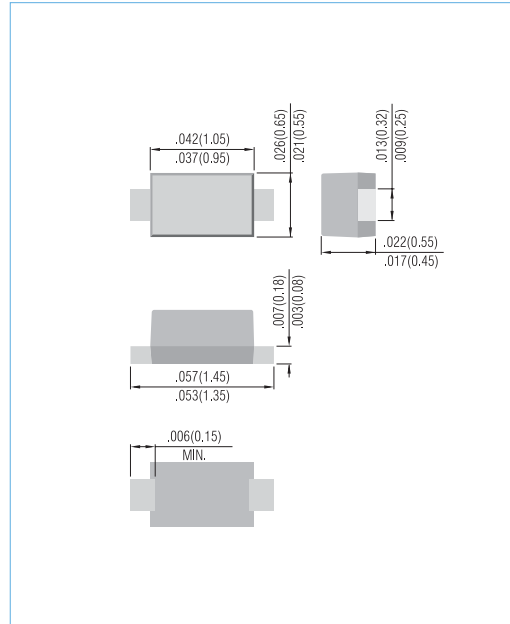

ABSOLUTE RATINGS

PARAMETER	SYMBOL	LIMITS	UNITS
Maximum Reverse Voltage	V_R	75	V
Peak Reverse Voltage	V_{RRM}	100	V
Continuous Forward Current	I_F	0.2	A
Non-repetitive Peak Forward Surge Current at $t=0.001$ ms	I_{FSM}	.0	A

THERMAL CHARACTERISTICS

PARAMETER	SYMBOL	LIMITS	UNITS
Power Dissipation (Note 1)	P_{TOT}	200	mW
Thermal Resistance, Junction to Ambient (Note 1)	$R_{\theta JA}$	635	$^{\circ}C/W$
Operating Junction and Storage Temperature Rang	T_J, T_{STG}	-55 to 150	$^{\circ}C$

Note 1.FR-4 Board = 70 x 60 x 1mm.



MMBD914TG

ELECTRICAL CHARACTERISTICS (T_J = 25°C, unless otherwise noted)

PARAMETER	SYMBOL	TEST CONDITIONS	MIN	TYP	MAX	UNITS
Reverse Breakdown Voltage	V _(BR)	I _R = 100μA	100	-	-	V
Reverse Current	I _R	V _R = 20V V _R = 75V	- -	- -	0.025 5.0	μA
Forward Voltage	V _F	I _F = 10mA	-	-	1.0	V
Total Capacitance	C _T	V _R = 0V, f = 1MHz	-	-	4.0	pF
Reverse Recovery Time (Figure 1)	T _{RR}	I _F = I _R = 10mA, R _L = 100Ω	-	-	4.0	ns

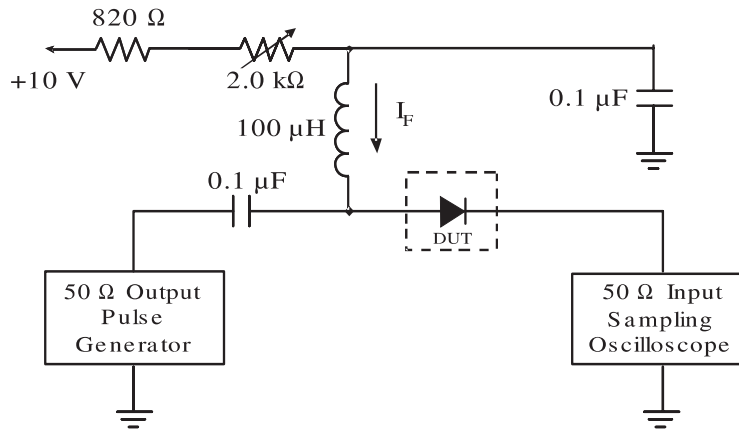

- Notes:
1. A 2.0kΩ variable resistor adjusted for a forward current (I_F) to 10mA
 2. Input pulse is adjusted to I_{R(peak)} is equal to 10mA

Figure 1. REVERSE RECOVERY TIME EQUIVALENT TEST CIRCUIT



MMBD914TG

ELECTRICAL CHARACTERISTICS CURVE

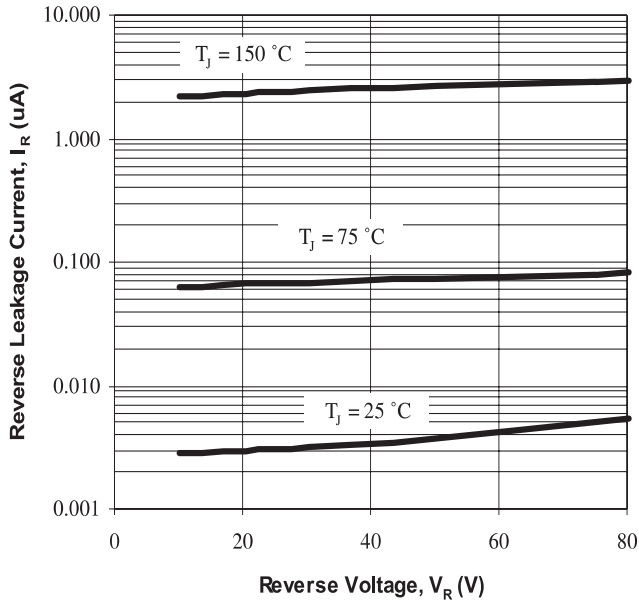

Fig.1 . Reverse Current vs. Reverse Voltage

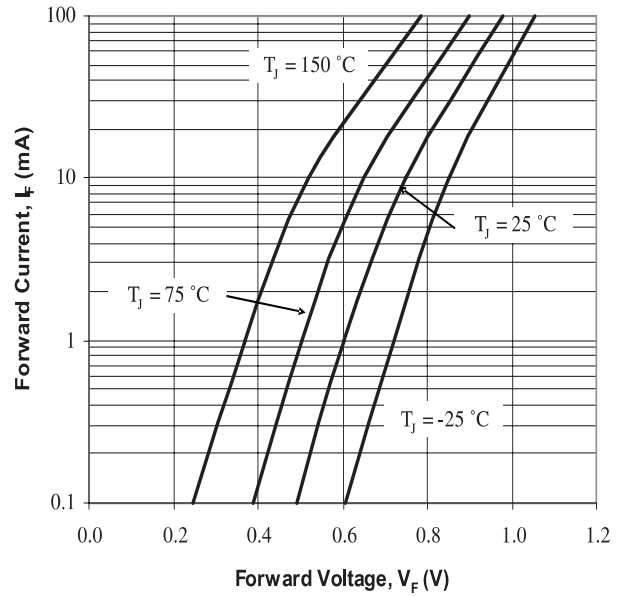

Fig.2. Forward Current vs. Forward Voltage

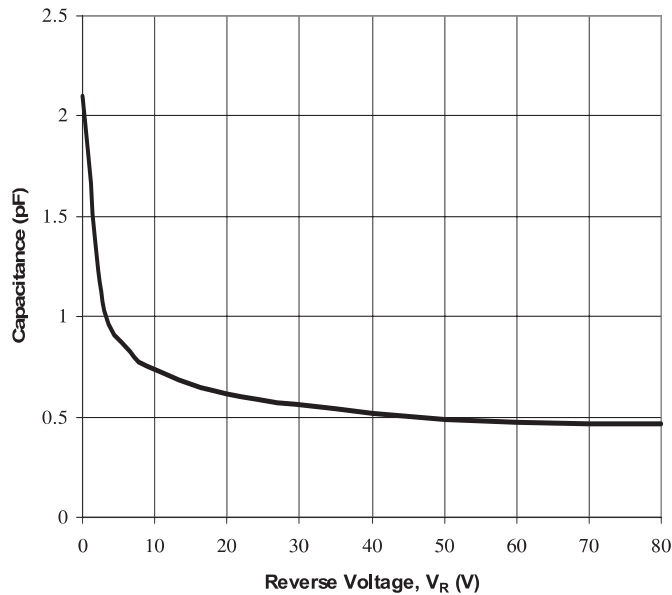

Fig.3. Capacitance vs. Reverse Voltage



MMBD914TG

MOUNTING PAD LAYOUT

SOD-723

Unit: inch (mm)

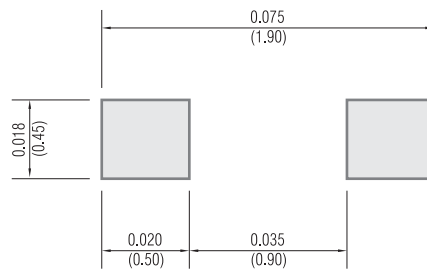

ORDER INFORMATION

- Packing information

T/R - 8K per 7" plastic Reel

LEGAL STATEMENT

Copyright PanJit International, Inc 2009

The information presented in this document is believed to be accurate and reliable. The specifications and information herein are subject to change without notice. Pan Jit makes no warranty, representation or guarantee regarding the suitability of its products for any particular purpose. Pan Jit products are not authorized for use in life support devices or systems. Pan Jit does not convey any license under its patent rights or rights of others.