



TABLE OF CONTENTS

1.DATA SHEET

PAGE 1

2.MARKING

PAGE 3

3.PACKING

PAGE 4

4.HIGH RELIABILITY TEST SPEC.

PAGE 8



KBPC600~KBPC6010

SILICON BRIDGE RECTIFIERS

VOLTAGE 50 to 1000 Volts **CURRENT** 6 Amperes

CP-6 / K-6 Unit: inch (mm)

FEATURES

- High temperature metallurgically bonded internal rectifiers
- Please package has Underwrites Laboratory Flammability Classification 94V-0
- Exceeds environmental standards of MIL-STD-19500
- High temperature soldering guaranteed : 265°C / 10 seconds / .375" (9.5mm) lead length at 5 lbs.(2.3kg) tension
- Pb free product are available: 99% Sn above can meet RoHS environment substance directive request

MECHANICAL DATA

Case : void-free plastic package
 Terminals : Leads solderable per MIL-STD-750, Method 2026
 Mounting : Thru hole for #6 screw
 Mounting position : Any
 Weight : 3.2 grams

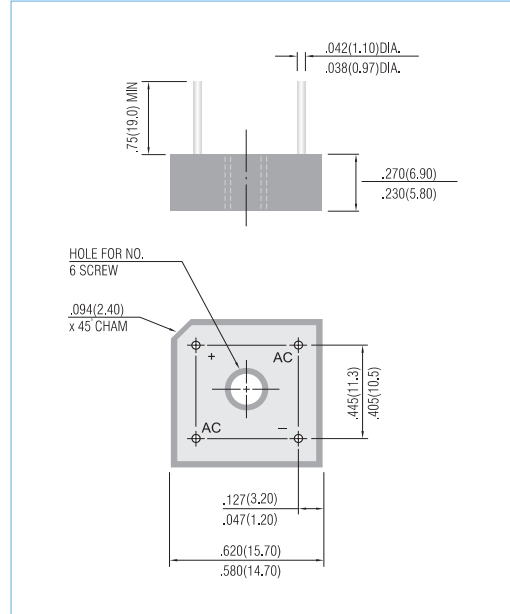

MAXIMUM RATINGS AND ELECTRICAL CHARACTERISTICS

Ratings at 25°C ambient temperature unless otherwise specified.
 Single phase, half wave, 60Hz, Resistive or inductive load.
 For capacitive load, derate current by 20%

RATINGS	SYMBOL	KBPC600	KBPC601	KBPC602	KBPC604	KBPC606	KBPC608	KBPC6010	UNITS
Maximum Recurrent Peak Reverse Voltage	V _{RRM}	50	100	200	400	600	800	1000	V
Maximum RMS Bridge Input Voltage	V _{RMS}	35	70	140	280	420	560	700	V
Maximum DC Blocking Voltage	V _{DC}	50	100	200	400	600	800	1000	V
Maximum Average Rectified Output see Fig2	I _{AV}					6.0 4.0 4.0			A
Peak One Cycle Surge Overload Current	I _{FSM}					125			A
Maximum Forward Voltage Drop per Element at 3.0A DC & 25°C See Fig 3	V _F					1.0			V
Maximum Reverse Leakage at Rated DC Blocking Voltage at T _A =25°C per Element See Fig 4 at T _A =100°C	I _R					10.0 1.0			μA mA
Operating Temperature Range	T _J					-55 To + 125			°C
Storage Temperature Range	T _{STG}					-55 To + 150			°C

NOTES: 1. Unit mounted on metal chassis
 2. Unit mounted on P.C. board.



KBPC600~KBPC6010

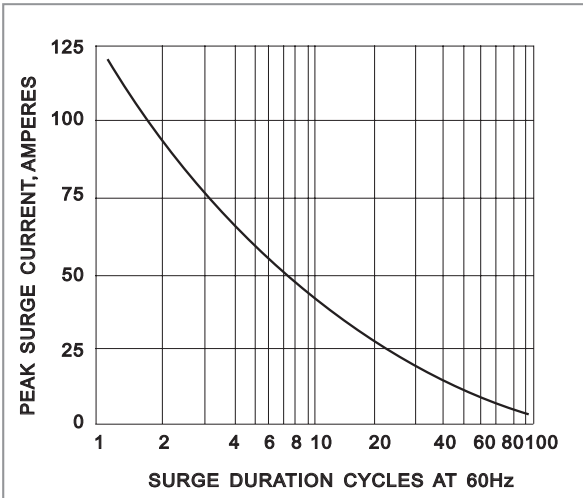

FIG.1-NON-RECURRENT SURGE RATING

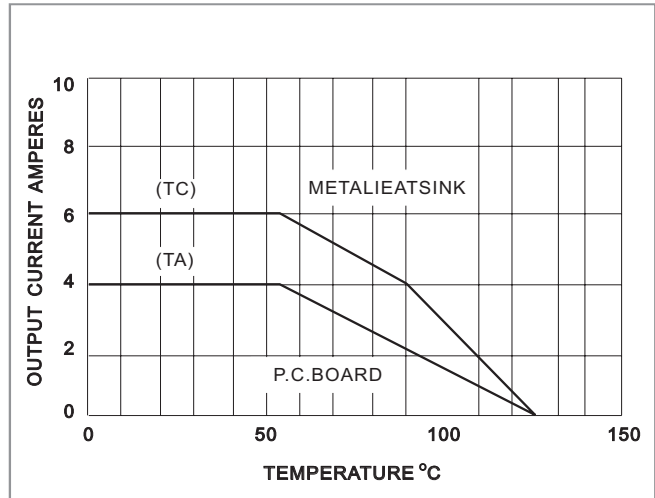

FIG.2-DERATING CURVE FOR OUTPUT RECTIFIED CURRENT

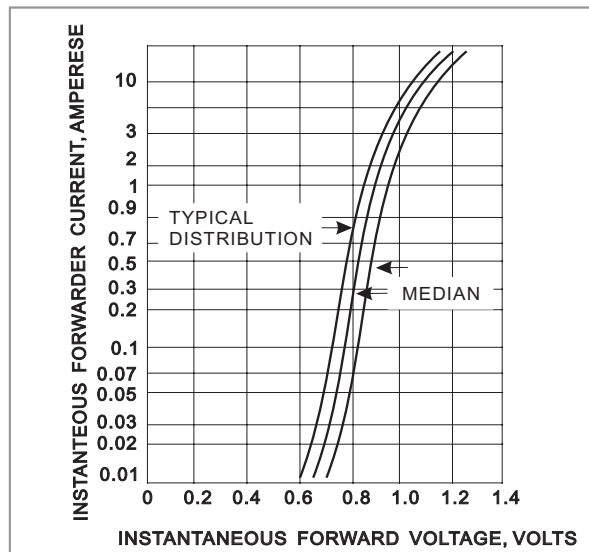

FIG.3-TYPICAL FORWARD CHARACTERISTICS(25°C)

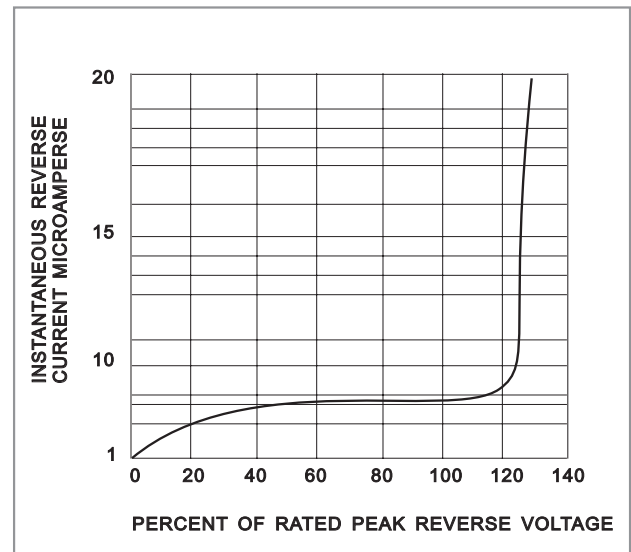
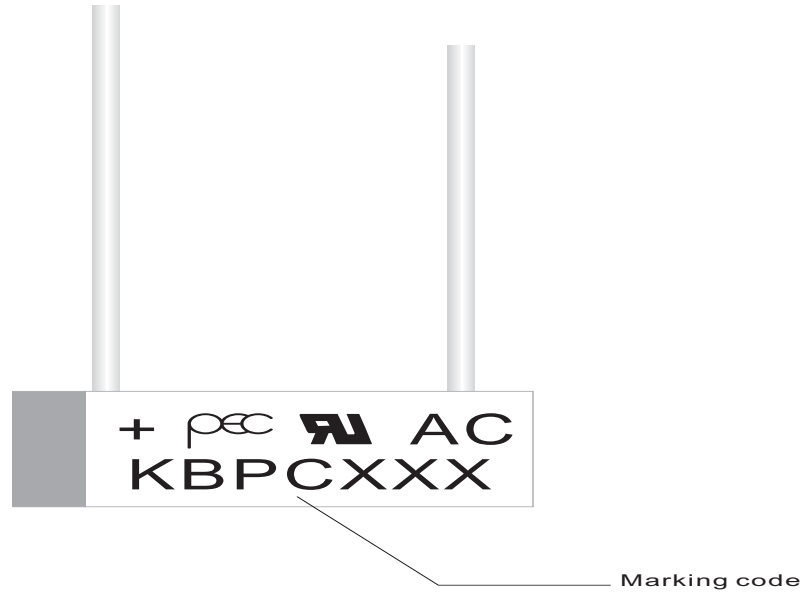

FIG.4-TYPICAL REVERSE CHARACTERISTIC (25°C)



2. MARKING





3. PACKING

INNER BOX

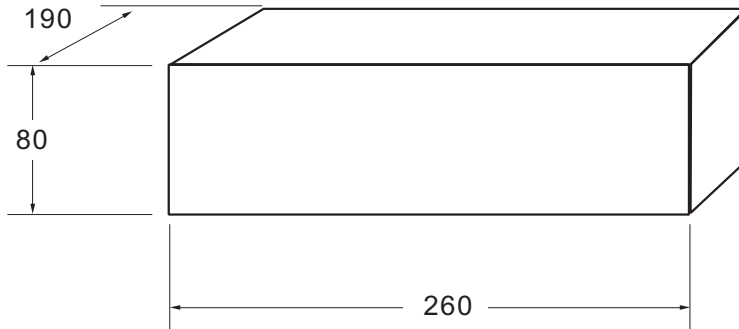

Box Dimensions : mm
Quantity per Carton: 400 pcs

CARTON

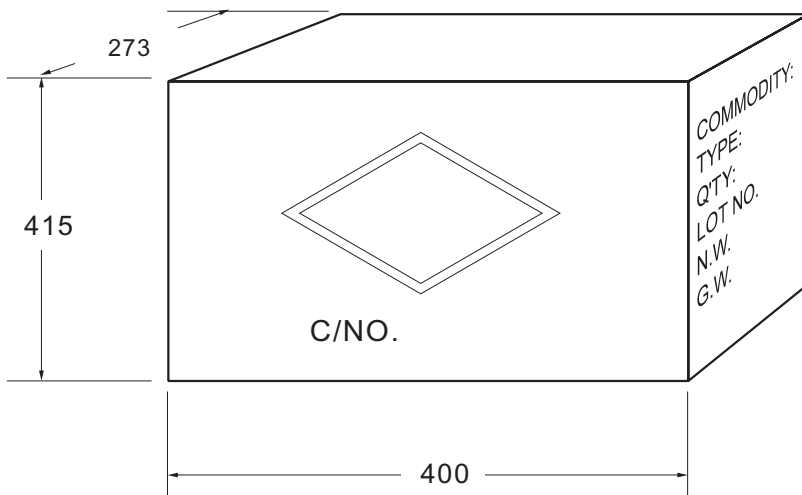

Box Dimensions : mm
Quantity per Box: 4,000 pcs

SHIPPING MARK

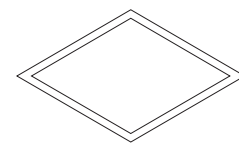

C/NO.
PRODUCT COUNTRY

SIDE MARK

COMMODITY:
TYPE:
Q'TY:
LOT NO.
N.W.
G.W.
PANJIT
INTERNATIONAL INC.



Bulk Packing

PACKAGE	INNER SIZE	BOX	CARTON SIZE	CARTON	APPROX. GROSS WEIGHT
	(m/m)	(EA)	(m/m)	(EA)	(Kg)
Bulk Packing					
A-405	198 x 84 x 20	10,000	459 x 214 x 256	50,000	18.2
AG / RB-20 / WOB	258x190x77	1,000	395x270x400	10,000	17.0
AM	260 x 190 x 80	1,000	400 x 273 x 415	10,000	15
CM / KBPC	193 x 193 x 46	50	405 x 210 x 265	500	18
CMW / KBPC-W	193 x 193 x 46	50	405 x 210 x 265	500	16.5
KBPC-P / CP-15/25/35/50	193 x 193 x 46	50	405 x 210 x 265	500	14.5
KBPC-PW / CPW-15/25/35/50	193 x 193 x 46	50	405 x 210 x 265	500	13
CP-3 / 6	260 x 190 x 80	400	400 x 273 x 415	4,000	8.5
CP-8 / 10	260 x 190 x 80	250	400 x 273 x 415	2,500	14
DIP	-	-	495 x 214 x 256	12,000	8.8
DO-15	200 x 85 x 25	1,000	459 x 214 x 256	40,000	17
DO-201AD	200 x 85 x 40	500	495 x 214 x 256	12,500	15.8
DO-201AE	200 x 85 x 40	500	495 x 214 x 256	12,500	15.8
DO-34	96 x 80 x 42	2,000	410 x 335 x 265	120,000	12
DO-35	96 x 80 x 42	2,000	410 x 335 x 265	120,000	13.8
DO-41	240 x 100 x 90	5,000	410 x 335 x 265	60,000	20
DO-41G	96 x 80 x 42	1,000	410 x 335 x 265	60,000	20
FL	270 x 225 x 50	500	463 x 283 x 185	3,000	18.2
GBJ	352 x 337 x 44	600	375 x 360 x 213	2,400	25.4
GBL	350 x 337 x 44	960	375 x 360 x 213	3,840	13.1
GBP	350 x 337 x 44	1,120	375 x 360 x 213	4,480	10.7
GBPC	195 x 195 x 40	50	460 x 215 x 260	500	14.5
GBPCW	195 x 195 x 40	50	460 x 215 x 260	500	13
GBU	350 x 337 x 44	800	375 x 360 x 213	3,200	17
GL	195 x 195 x 40	80	460 x 215 x 260	800	11
GPJ	500 x 150 x 145	750	572 x 306 x 218	1,500	17
KBJ	219 x 177 x 44	200	367 x 232 x 250	2,000	16.3
KBPM	490 x 150 x 110	1,200	510 x 335 x 240	4,800	19
KBU	270 x 225 x 50	200	463 x 283 x 185	1,200	10
MDI	350 x 337 x 44	6,000	375 x 360 x 390	48,000	14.4
P-600	208 x 90 x 83	500	495 x 214 x 256	5,000	11.9
R-1	198 x 84 x 20	1,000	495 x 214 x 256	50,000	18.2
SDIP	-	-	495 x 214 x 256	24,000	16.8
TO / ITO-220	555 x 145 x 95	2,000	572 x 306 x 218	8,000	19
TO-251AB	560 x 210 x 79	8,400	572 x 306 x 218	33,600	22
TO-247AD	-	-	536 x 243 x 100	1,500	13.2
KBP	258x190x77	1,000	395x270x400	10,000	18.0
KBL	230x147x50	200	460x245x275	3,000	17.25
K3 / K6	210x115x90	200	600x235x198	2,000	7.3/8.8
K8	210x115x90	200	600x235x198	2,000	13.8
K10/K15/K25/K35/K50M	193x193x46	50	405x210x265	500	17.0
K10/K15/K25/K35/K50P	193x193x46	50	405x210x265	500	17.0
K10/K15/K25/K35/K50W	193x193x46	50	405x210x265	500	17.0



Reel Packing

PACKAGE	REEL	COMPONENT SPACE	TAPE SPACE	REEL DIA	CARTON SIZE	CARTON	APPROX. GROSS WEIGHT
	(pcs)	(m/m)	(m/m)	(m/m)	(m/m)	(EA)	(Kg)
Reel Packing							
A-405	5,000	5	52	330	340 x 340 x 410	25,000	11.3
TO-263	800	16	24	330	375 x360 x 390	6,400	15
DO-15	4,000	5	52	330	340 x 340 x 410	20,000	11
DO-201AD	1,250	10	52	330	340 x 340 x 410	6,250	9.2
DO-201AE	1,250	10	52	330	340 x 340 x 410	6,250	9.2
DO-34	10,000	5	52	360	360 x 360 x 395	50,000	9.5
DO-35	10,000	5	52	360	360 x 360 x 395	50,000	12
DO-41	5,000	5	52	330	360 x 360 x 395	25,000	13
DO-41G	5,000	5	52	360	360 x 360 x 395	25,000	13
TO-252	3,000	8	16	330	375 x 360 x 390	42,000	20.2
MDI	3,000	8	12	330	375 x360 x 390	48,000	14.4
QUADRO-MELF	2,500	4	-	178	385 x 380 x 260	200,000	13.5
MELF/DL-41	5,000	4	-	330	350 x 350 x 300	100,000	14
MICRO-MELF	2,500	4	-	178	385 x 380 x 260	200,000	13.5
MINI-MELF	10,000 / 2,500	4	-	330 / 178	360 x 360 x 395 / 385 x 380 x 260	200,000	14.0 / 13.5
P-600	800	10	52	330	340 x 340 x 410	4,000	11
QFN 1.6 x 1.6	4,000	4	8	178	390 x 240 x 420	200,000	7.8
R-1	5,000	5	52	330	340 x 340 x 410	25,000	6.3
SDIP	1,500	12	16	330	375 x360 x 390	21,000	16.3
SMA	7,500 / 1,800	4	12	330 / 178	375 x360 x 390 / 390 x 240 x 420	120,000 / 72,000	17.5 / 10
SMB	3,000 / 500	8	12	330 / 178	375 x360 x 390 / 390 x 240 x 420	48,000 / 20,000	13.6 / 7.5
SMC	3,000 / 500	12	16	330 / 178	375 x360 x 390 / 390 x 240 x 420	42,000 / 15,000	6.2 / 7.3
SOD-123	10,000 / 3,000	4	8	330 / 178	375 x 360 x 213 / 390 x 270 x 400	120,000 / 240,000	6.4 / 9.4
SOD-123FL	10,000 / 3,000	4	8	330 / 178	375 x 360 x 213 / 390 x 270 x 400	120,000 / 240,000	6.4 / 9.4
SOD-323	12,000 / 5,000	4	8	330 / 178	375 x 360 x 213 / 390 x 270 x 400	144,000 / 400,000	10 / 15.2
SOT-23	12,000 / 3,000	4	8	330 / 178	375 x 360 x 213 / 390 x 270 x 400	144,000 / 240,000	6.4 / 9.4
SOT-323	12,000 / 3,000	4	8	330 / 178	375 x 360 x 213 / 390 x 270 x 400	144,000 / 240,000	6.4 / 9.4
SOT-363	10,000 / 3,000	4	8	330 / 178	735 x 365 x 292 / 390 x 240 x 420	300,000 / 150,000	15.66 / 7.0
SOT-353	10,000 / 3,000	4	8	330 / 178	735 x 365 x 292 / 390 x 240 x 420	300,000 / 150,000	15.66 / 7.0
TO-92	2,000	-	-	335	390 x 390 x 280	8,000	6.067
SOD-523	12,000 / 5,000	4	8	330 / 178	375 x 360 x 213 / 390 x 270 x 400	144,000 / 400,000	10 / 15.2
QFN 2.0 x 2.0	5,000 / 3,000 / 1,000	4	8	330 / 178 / 178	553 x 365 x 358 / 333 x 240 x 257 / 333 x 240 x 257	45,000 / 39,000 / 13,000	4.5 / 3.0 / 2.5
SOT23-6L	3,000 / 2,500 / 1,000	4	8	330 / 178 / 178	553 x 365 x 358 / 333 x 240 x 257 / 333 x 240 x 257	39,000 / 32,500 / 13,000	3.0 / 3.0 / 2.5
SOIC-08	3,000 / 1,500 / 1,000	4	8	330 / 330 / 178	553 x 365 x 358 / 553 x 365 x 358 / 333 x 240 x 257	39,000 / 13,500 / 13,000	6.5 / 5.0 / 3.5



Ammunition Packing

PACKAGE	AMMO (pcs)	COMPONENT SPACE (m/m)	TAPE SPACE (m/m)	BOX SIZE (m/m)	CARTON SIZE (m/m)	CARTON (EA)	APPROX. GROSS WEIGHT (Kg)
Ammunition Packing							
A-405	5,000	5	26	255 x 50 x 150	339 x 276 x 330	60,000	16.0
A-405	5,000	5	52	255 x 75 x 150	339 x 276 x 330	40,000	16.0
DO-15	3,000	5	52	255 x 75 x 150	339 x 276 x 330	24,000	11.9
DO-201AD	1,250	10	52	255 x 75 x 150	339 x 276 x 330	10,000	14.0
DO-201AE	1,250	10	52	255 x 75 x 150	339 x 276 x 330	10,000	14.0
DO-34	5,000	5	26	248 x 80 x 48	410 x 335 x 265	150,000	15.5
DO-34	5,000	5	52	248 x 80 x 75	410 x 335 x 265	100,000	14.1
DO-35	5,000	5	26	248 x 80 x 48	410 x 335 x 265	150,000	20.0
DO-35	5,000	5	52	248 x 80 x 75	410 x 335 x 265	100,000	15.7
DO-41	5,000	5	52	255 x 75 x 150	339 x 276 x 330	40,000	19.1
DO-41G	2,500	5	26	248 x 80 x 48	410 x 335 x 265	75,000	21.5
DO-41G	2,500	5	52	248 x 80 x 75	410 x 335 x 265	50,000	19.0
P-600	400	10	52	255 x 75 x 150	339 x 276 x 330	3,200	9.0
R-1	5,000	5	26	255 x 50 x 150	339 x 276 x 330	40,000	11.0
R-1	5,000	5	52	255 x 75 x 150	339 x 276 x 330	40,000	16.0



4. HIGH RELIABILITY TESTING SPEC.

NO	TEST ITEM	TEST CONDITION	REFERENCE DOCUMENT	LOT QUALITY LEVEL	REMARK
1	TEMPERATURE CYCLING (T.C.T)	Ta = -55 + 0, -3 °C 10min Ta = +150 +/- °C 10min FOR 20 CYCLE	MIL-STD-750D METHOD-1051.5	LTPD 10 S.s. = 22 ACCEPT FOR 0 FAILURE ONLY.	
2	HIGH TEMPERATURE STORAGE LIFE (H.T.S.L)	Ta = 150 +/- 5 °C TESTING TIME: 168 HRS 250 HRS 500 HRS	MIL-STD-750D METHOD-1031.2	LTPD10 S.s. = 22 ACCEPT FOR 0 FAILURE ONLY.	
3	SOLDERABILITY TEST	TEMPERATURE OF SOLDER POT = 245 +/- 5 °C TIME FOR DIPPING FLUX = 5-10 SEC TIME FOR DIPPING IN SOLDER = 5 +/- 0.5 SEC DIPPING DEPTH = 0.05 inch max FOR ONE CYCLE	MIL-STD-750D	METHOD-2026.10 LTPD 7 S.s. = 32 ACCEPT FOR 0 FAILURE ONLY.	
4	HIGH TEMPERATURE REVERSE BIAS (H.T.R.B)	Ta = 150 +/- 5 °C VR = 80 % VR (CUSTOM SECP) TESTING TIME: 168 HRS 250 HRS 500 HRS	MIL-STD-750D METHOD-1038.3	LTPD10 S.s. = 22 ACCEPT FOR 0 FAILURE ONLY.	
5	CONTINUE FORWARD OPERATING LIFE (C.F.O.L)	Ta = 55 °C I = IO +/- 10 % TESTING TIME: 168 HRS 250 HRS 500 HRS	MIL-STD-750D METHOD-1027.3	LTPD10 S.s. = 22 ACCEPT FOR 0 FAILURE ONLY.	
6	THERMAL SHOCK (T.S.T)	HOT TANK T = 100 °C + 10 / -2 °C t = 5 min COLD TANK T = 0 °C + 2 / -10 °C t = 5 min 15 CYCLE TIME BETWEEN TRANSFERRING DO'NOT EXCEED 10 SECOND.	MIL-STD-750D METHOD-1056.7	LTPD10 S.s. = 22 ACCEPT FOR 0 FAILURE ONLY.	
7	PRESSURE COOKER (P.C.T)	Ta = 121 °C P = 1.2 kg / cm ² TIME = 96 HRS	JEDEC JESD22-A102-C	LTPD10 S.s. = 22 ACCEPT FOR 0 FAILURE ONLY.	
8	INTERMITTENT FORWARD OPERATING LIFE (I.F.O.L)	I = Io x 1.0 POWER ON : 30 SEC POWER OFF : 50 SEC TESTING TIME: 2000 CYCLES	MIL-STD-750D METHOD 1036.3	LTPD10 S.s. = 22 ACCEPT FOR 0 FAILURE ONLY.	
9	FORWARD SURGE CURRENT (I.F.S.M)	SQ WAVE OR SINE WAVE IFSM-DATE SHEET SPEC. TIME = 8.3 Msec T = 1 CYCLE	MIL-STD-750D METHOD 4066.3	LTPD10 S.s. = 22 ACCEPT FOR 0 FAILURE ONLY.	
10	HUMIDITY	Ta = 85 °C RH = 85 % TESTING TIME: 168 HRS 250 HRS 500 HRS	MIL-STD-750D METHOD 1021.1	LTPD10 S.s. = 22 ACCEPT FOR 0 FAILURE ONLY.	
11	SOLDERABILITY RESISTANCE	TEMPERATURE OF SOLDER POT = 260 +/- 5 °C TIME FOR DIPPING IN SOLDER = 10 + 2 / -0 SEC DIPPING DEPTH = 1.57 +/- 0.79 mm BELOW BODY FOR ONE CYCLE	MIL-STD-750D METHOD 2031.1	LTPD10 S.s. = 22 ACCEPT FOR 0 FAILURE ONLY.	

SCHOTTKY PRODUCT TESTING TEMPERATURE 100 °C MAX (NORMAL)