

DATA SHEET

BZM5221B SERIES

SURFACE MOUNT ZENER DIODES

VOLTAGE 2.4 to 47 Volts

POWER 500 mWatts

MICRO-MELF

Unit : inch (mm)

FEATURES

- Planar Die construction
- 500mW Power Dissipation
- Ideally Suited for Automated Assembly Processes
- In compliance with EU RoHS 2002/95/EC directives

MECHANICAL DATA

- Case: Molded Glass MICRO-MELF
- Terminals: Solderable per MIL-STD-750, Method 2026
- Polarity: See Diagram Below
- Approx. Weight: 0.008 grams
- Mounting Position: Any
- Packing information

T/R - 2.5K per 7" plastic Reel

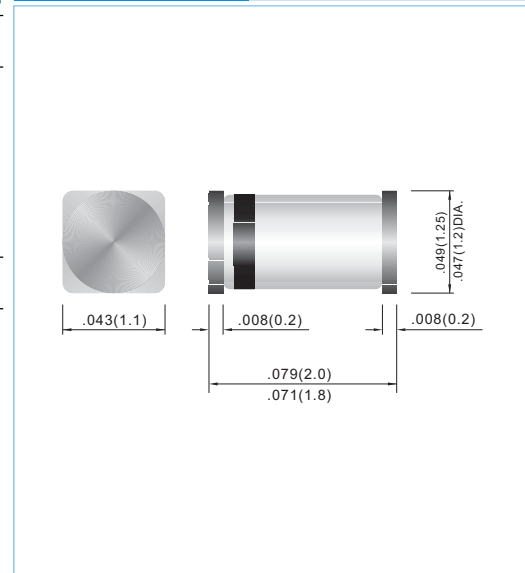

MAXIMUM RATINGS AND ELECTRICAL CHARACTERISTICS

Parameter	Symbol	Value	Units
Power Dissipation at Tamb=25 °C	P _{TOT}	500	mW
Junction Temperature	T _J	175	°C
Storage Temperature Range	T _s	-65 to +175	°C
Valid provided that leads at a distance of 10mm from case are kept at ambient temperature			

Parameter	Symbol	Min.	Typ.	Max.	Units
Thermal Resistance Junction to Ambient Air	R _{θJA}	--	--	0.3	K/mW
Forward Voltage at I _F = 100mA	V _F	--	--	1	V
Valid provided that leads at a distance of 10mm from case are kept at ambient temperature.					

Notes.

- STANDARD VOLTAGE TOLERANCE IS ± 5% AND :
- SUFFIX " A " FOR ± 3%
 - SUFFIX " B " FOR ± 5%
 - SUFFIX " C " FOR ± 10%
 - SUFFIX " D " FOR ± 20%

Part Number	Nominal Zener Voltage			Max. Zener Impedance				Max Reverse Leakage Current	
	V _Z @ I _{ZT}			Z _{ZT} @ I _{ZT}		Z _{ZK} @ I _{ZK}		I _R @ V _R	
	Nom. V	Min. V	Max. V	Ω	mA	Ω	mA	uA	V
BZM5221B	2.40	2.28	2.52	30	20.0	1200	0.25	100	1.0
BZM5222B	2.50	2.38	2.63	30	20.0	1250	0.25	100	1.0
BZM5223B	2.70	2.57	2.84	30	20.0	1300	0.25	75	1.0
BZM5224B	2.80	2.66	2.94	30	20.0	1400	0.25	75	1.0
BZM5225B	3.00	2.85	3.15	29	20.0	1600	0.25	50	1.0
BZM5226B	3.30	3.14	3.47	28	20.0	1600	0.25	25	1.0
BZM5227B	3.60	3.42	3.78	24	20.0	1700	0.25	15	1.0
BZM5228B	3.90	3.71	4.10	23	20.0	1900	0.25	10	1.0
BZM5229B	4.30	4.09	4.52	22	20.0	2000	0.25	5.0	1.0
BZM5230B	4.70	4.47	4.94	19	20.0	1900	0.25	5.0	2.0
BZM5231B	5.10	4.85	5.36	17	20.0	1600	0.25	5.0	2.0
BZM5232B	5.60	5.32	5.88	11	20.0	1600	0.25	5.0	3.0
BZM5233B	6.00	5.70	6.30	7	20.0	1600	0.25	5.0	3.5
BZM5234B	6.20	5.89	6.51	7	20.0	1000	0.25	5.0	4.0
BZM5235B	6.80	6.46	7.14	5	20.0	750	0.25	3.0	5.0
BZM5236B	7.50	7.13	7.88	6	20.0	500	0.25	3.0	6.0
BZM5237B	8.20	7.79	8.61	8	20.0	500	0.25	3.0	6.5
BZM5238B	8.70	8.27	9.14	8	20.0	600	0.25	3.0	6.5
BZM5239B	9.10	8.65	9.56	10	20.0	600	0.25	3.0	7.0
BZM5240B	10.00	9.50	10.50	17	20.0	600	0.25	3.0	8.0
BZM5241B	11.00	10.45	11.55	22	20.0	600	0.25	2.0	8.4
BZM5242B	12.00	11.40	12.60	30	20.0	600	0.25	1.0	9.1
BZM5243B	13.00	12.35	13.65	13	9.5	600	0.25	0.5	9.9
BZM5244B	14.00	13.30	14.70	15	9.5	600	0.25	0.1	10.0
BZM5245B	15.00	14.25	15.75	16	8.5	600	0.25	0.1	11.0
BZM5246B	16.00	15.20	16.80	17	7.8	600	0.25	0.1	12.0
BZM5247B	17.00	16.15	17.85	19	7.4	600	0.25	0.1	13.0
BZM5248B	18.00	17.10	18.90	21	7.0	600	0.25	0.1	14.0
BZM5249B	19.00	18.05	19.95	23	6.6	600	0.25	0.1	14.0
BZM5250B	20.00	19.00	21.00	25	6.2	600	0.25	0.1	15.0
BZM5251B	22.00	20.90	23.10	29	5.6	600	0.25	0.1	17.0
BZM5252B	24.00	22.80	25.20	33	5.2	600	0.25	0.1	18.0
BZM5253B	25.00	23.75	26.25	35	5.0	600	0.25	0.1	19.0
BZM5254B	27.00	25.65	28.35	41	4.6	600	0.25	0.1	21.0
BZM5255B	28.00	26.60	29.40	44	4.5	600	0.25	0.1	21.0
BZM5256B	30.00	28.50	31.50	49	4.2	600	0.25	0.1	23.0
BZM5257B	33.00	31.35	34.65	58	3.8	700	0.25	0.1	25.0
BZM5258B	36.00	34.20	37.80	70	3.4	700	0.25	0.1	27.0
BZM5259B	39.00	37.05	40.95	80	3.2	800	0.25	0.1	30.0
BZM5260B	43.00	40.85	45.15	93	3.0	900	0.25	0.1	33.0
BZM5261B	47.00	44.65	49.35	150	2.7	1000	0.25	0.1	36.0
BZM5262B	51.00	48.45	53.55	125	2.5	1100	0.25	0.1	39.0
BZM5263B	56.00	53.20	58.80	150	2.2	1300	0.25	0.1	43.0
BZM5264B	60.00	57.00	63.00	170	2.1	1400	0.25	0.1	46.0
BZM5265B	62.00	58.90	65.10	185	2.0	1400	0.25	0.1	47.0
BZM5266B	68.00	64.60	71.40	230	1.8	1600	0.25	0.1	52.0
BZM5267B	75.00	71.25	78.75	270	1.7	1700	0.25	0.1	56.0

RATING AND CHARACTERISTIC CURVES

