



**TABLE OF CONTENTS**

1.DATA SHEET

PAGE 1

2.MARKING

PAGE 4

3.TAPING

PAGE 5

4.PACKING

PAGE 6

5.HIGH RELIABILITY SPEC.

PAGE 10



## BC807 SERIES

### PNP GENERAL PURPOSE TRANSISTORS

**VOLTAGE** 45 Volts **POWER** 225 mWatts

SOT-23

Unit: inch (mm)

#### FEATURES

- General purpose amplifier applications
- PNP epitaxial silicon, planar design
- Collector current  $I_C = 500\text{mA}$
- Pb free product are available : 99% Sn above can meet RoHS environment substance directive request

#### MECHANICAL DATA

Case: SOT-23, Plastic

Terminals: Solderable per MIL-STD-750, Method 2026

Approx. Weight: 0.008 gram

Device Marking : BC807-16 : 7A

BC807-25 : 7B

BC807-40 : 7C

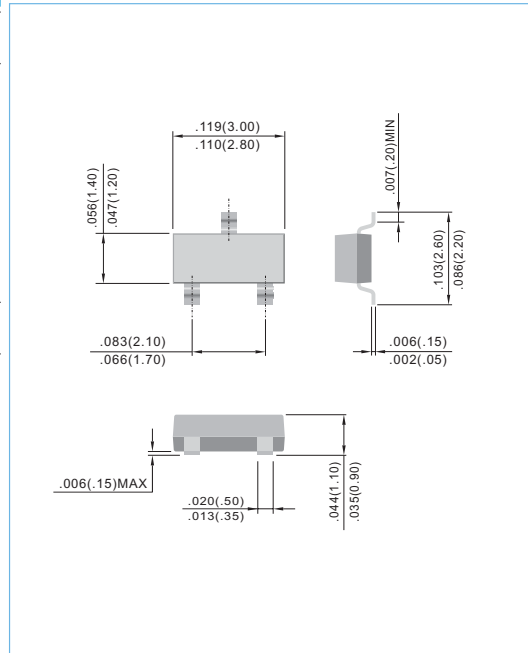
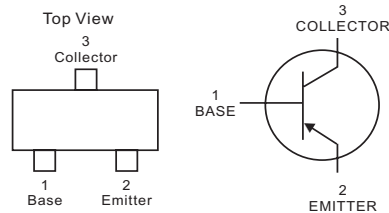

#### MAXIMUM RATINGS

PARAMETER	SYMBOL	Value	UNIT
Collector-Emitter Voltage	$V_{CEO}$	-45	v
Collector-Base Voltage	$V_{CBO}$	-50	v
Emitter-Base Voltage	$V_{EBO}$	-5.0	v
Collector Current - Continuous	$I_C$	-500	mA
Max Power Dissipation (Note 1)	$P_{TOT}$	225	mW
Junction and Storage Temperature Range	$T_J, T_{STG}$	-55 to 150	°C

#### THERMAL CHARACTERISTICS

PARAMETER	SYMBOL	Value	UNIT
Thermal Resistance , Junction to Ambient	$R_{\theta JA}$	556	°C/W

Note 1 : Transistor mounted on FR-5 board 1.0x0.75x0.062 in



**ELECTRICAL CHARACTERISTICS(T<sub>J</sub>=25°C,unless otherwise notes)**

PARAMETER	SYMBOL	MIN.	TYP.	MAX.	UNIT
Collector-Emitter Breakdown Voltage (I <sub>C</sub> =-10mA, I <sub>B</sub> =0)	V <sub>(BR)CEO</sub>	-45	-	-	V
Collector-Emitter Breakdown Voltage (V <sub>EB</sub> =0V, I <sub>C</sub> =-100uA)	V <sub>(BR)CES</sub>	-50	-	-	V
Emitter-Base Breakdown Voltage (I <sub>E</sub> =-10uA, I <sub>C</sub> =0)	V <sub>(BR)EBO</sub>	-5.0	-	-	V
Emitter-Base Cutoff Current (V <sub>EB</sub> =-4V)	I <sub>EBO</sub>	-	-	-100	nA
Collector-Base Cutoff Current (V <sub>CB</sub> =-20V, I <sub>E</sub> =0)	I <sub>CBO</sub>	T <sub>J</sub> =25°C	-	-0.1	nA
		T <sub>J</sub> =150°C	-	-5.0	uA
DC Current Gain (I <sub>C</sub> =-100mA, V <sub>CE</sub> =-1V)	h <sub>FE</sub>	BC807-16	100	250	-
		BC807-25	160	400	-
(I <sub>C</sub> =-500mA, V <sub>CE</sub> =-1V)		250	600	-	
Collector-Emitter Saturation Voltage (I <sub>C</sub> =-500mA, I <sub>B</sub> =-50mA)	V <sub>CE(SAT)</sub>	-	-	-0.7	V
Base-Emitter Voltage (I <sub>C</sub> =-500mA, V <sub>CE</sub> =-1.0V)	V <sub>BE(ON)</sub>	-	-	-1.2	V
Collector-Base Capacitance (V <sub>CB</sub> =-10V, I <sub>E</sub> =0, f=1MHz)	C <sub>CB0</sub>	-	7.0	-	pF
Current Gain-Bandwidth Product (I <sub>C</sub> =-10mA, V <sub>CE</sub> =-5V, f=100MHz)	f <sub>T</sub>	100	-	-	MHz

**ELECTRICAL CHARACTERISTICS CURVES**

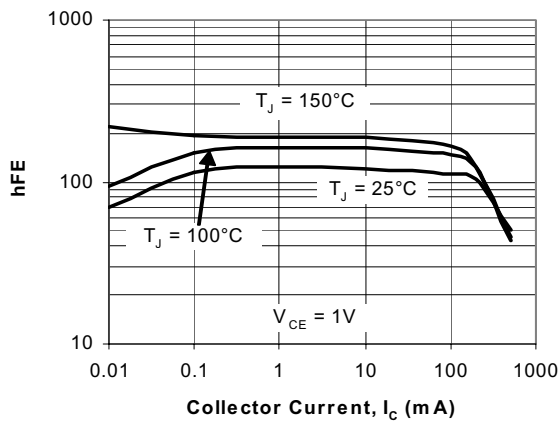

**Fig. 1. BC807-16 Typical h<sub>FE</sub> vs. I<sub>C</sub>**

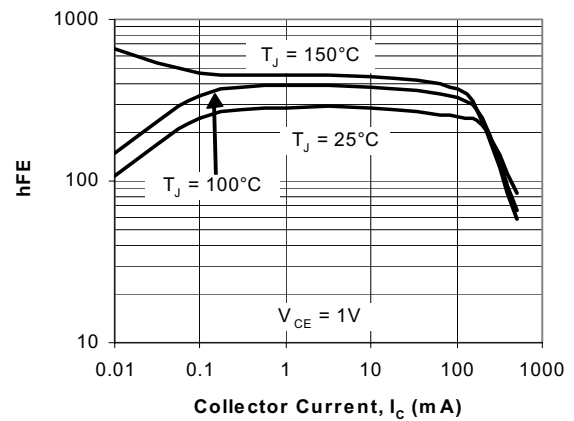

**Fig. 2. BC807-25 Typical h<sub>FE</sub> vs. I<sub>C</sub>**

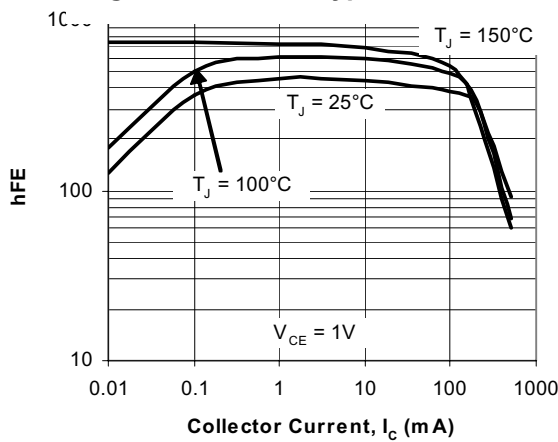

**Fig. 3. BC807-40 Typical h<sub>FE</sub> vs. I<sub>C</sub>**

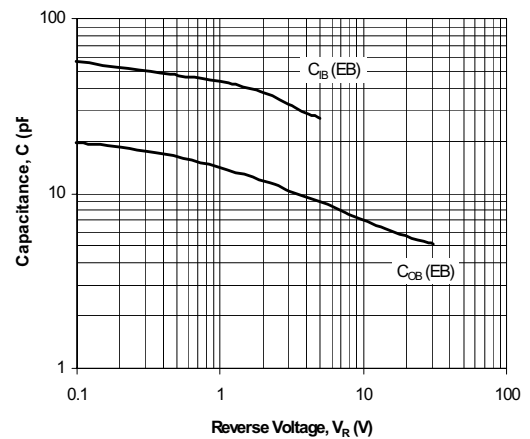

**Fig. 4. Typical Capacitances**



**MOUNTING PAD LAYOUT**

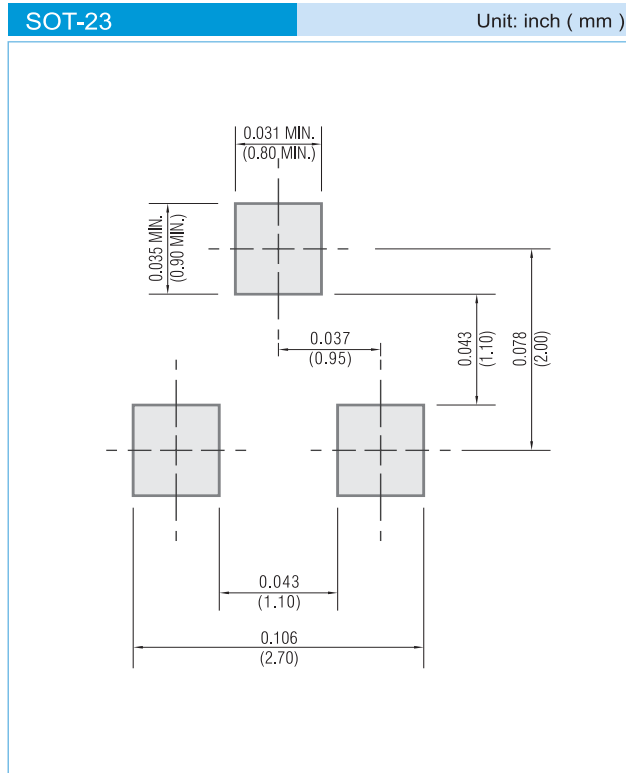

**ORDER INFORMATION**

- Packing information
  - T/R - 12K per 13" plastic Reel
  - T/R - 3K per 7" plastic Reel

**LEGAL STATEMENT**

**Copyright PanJit International, Inc 2006**

The information presented in this document is believed to be accurate and reliable. The specifications and information herein are subject to change without notice. Pan Jit makes no warranty, representation or guarantee regarding the suitability of its products for any particular purpose. Pan Jit products are not authorized for use in life support devices or systems. Pan Jit does not convey any license under its patent rights or rights of others.



## 2. MARKING

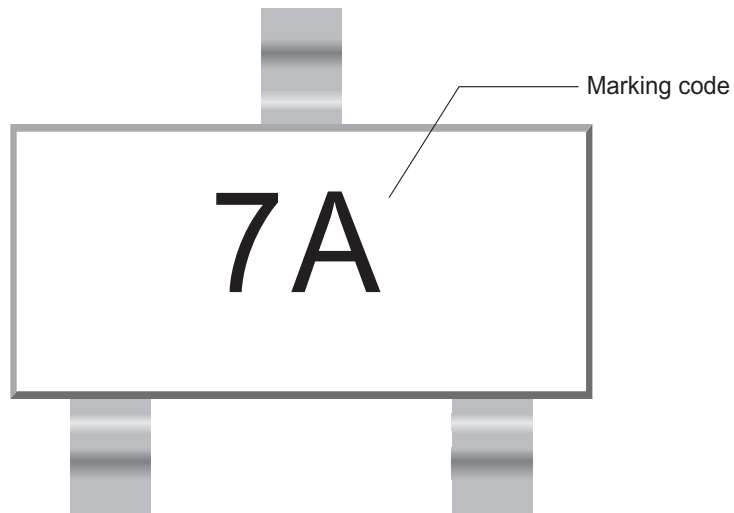



### 3. TAPING

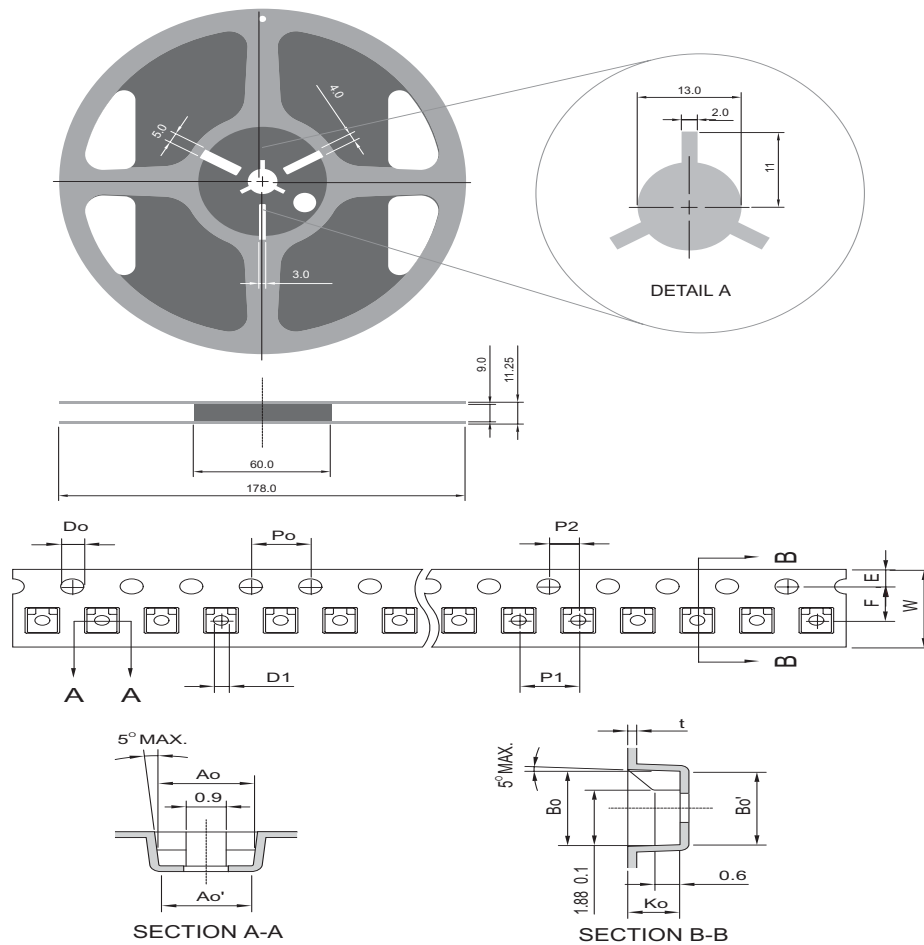

SYMBOL	mm (INCH)
TYPE SIZE 8.00 (0.314)	
Ao	3.15 ± 0.10(0.124 ± 0.004)
Bo	2.65 ± 0.10(0.104 ± 0.004)
Do	1.55 ± 0.05(0.610 ± 0.002)
D1	1.00 ± 0.10(0.039 ± 0.004)
E	1.75 ± 0.10(0.069 ± 0.004)
F	3.50 ± 0.05(0.137 ± 0.002)
Ko	1.17 ± 0.10(0.046 ± 0.004)
Po	4.00 ± 0.10(0.157 ± 0.004)
P1	4.00 ± 0.10(0.157 ± 0.004)
P2	2.00 ± 0.05(0.009 ± 0.002)
t	0.20 ± 0.05(0.008 ± 0.002)
W	8.00 ± 0.30(0.314 ± 0.012)
Ao'	3.00 ± 0.10(0.118 ± 0.004)
Bo'	2.55 ± 0.10(0.100 ± 0.004)

**NOTE:**

1. There shall be leader of 230 mm minimum which may consist of carrier and or cover tape follower by a minimum of 160 mm of carrier tape sealed with cover tape.
2. There shall be minimum of 160 mm of empty component pockets sealed with cover tape.
3. Devices are packed in accordance with EIA standard EIA-481-A and specifications given above.



## 4. PACKING

### REEL PACKING

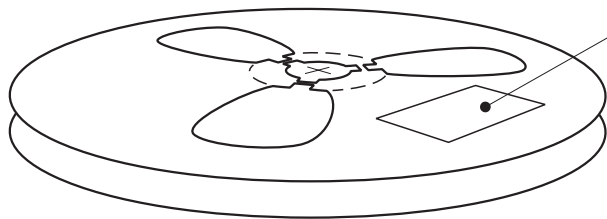

Quantity per Reel: 3,000 pcs

#### LABEL TYPE

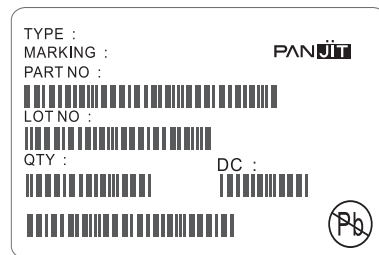

### CARTON

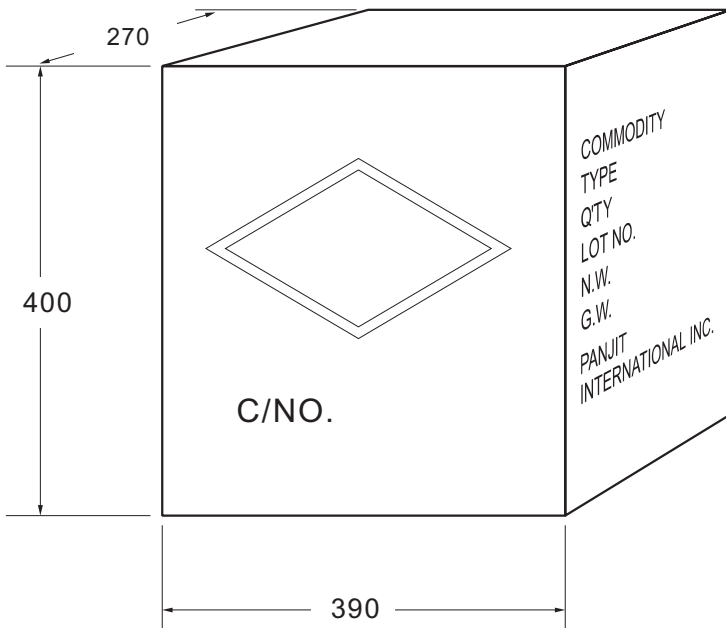

Box Dimensions : mm  
Quantity per Box: 240,000pcs

#### SHIPPING MARK

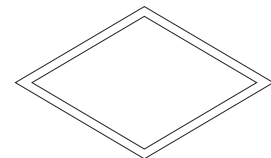

C/NO.  
PRODUCT COUNTRY

#### SIDE MARK

COMMODITY:  
TYPE:  
Q'TY:  
LOT NO.  
N.W.  
G.W.  
PANJIT  
INTERNATIONAL INC.



## Bulk Packing

PACKAGE	INNER SIZE	BOX	CARTON SIZE	CARTON	APPROX. GROSS WEIGHT
	(m/m)	(EA)	(m/m)	(EA)	(Kg)
<b>Bulk Packing</b>					
A-405	198 x 84 x 20	10,000	459 x 214 x 256	50,000	18.2
AG / RB-20 / WOB	258x190x77	1,000	395x270x400	10,000	17.0
AM	260 x 190 x 80	1,000	400 x 273 x 415	10,000	15
CM / KBPC	195 x 195 x 40	50	460 x 215 x 260	500	18
CMW / KBPC-W	195 x 195 x 40	50	460 x 215 x 260	500	16.5
KBPC-P / CP-15/25/35/50	195 x 195 x 40	50	460 x 215 x 260	500	14.5
KBPC-PW / CPW-15/25/35/50	195 x 195 x 40	50	460 x 215 x 260	500	13
CP-3 / 6	260 x 190 x 80	400	400 x 273 x 415	4,000	8.5
CP-8 / 10	260 x 190 x 80	250	400 x 273 x 415	2,500	14
DIP	-	-	495 x 214 x 256	12,000	8.8
DO-15	200 x 85 x 25	1,000	459 x 214 x 256	40,000	17
DO-201AD	200 x 85 x 40	500	495 x 214 x 256	12,500	15.8
DO-201AE	200 x 85 x 40	500	495 x 214 x 256	12,500	15.8
DO-34	96 x 80 x 42	2,000	410 x 335 x 265	120,000	12
DO-35	96 x 80 x 42	2,000	410 x 335 x 265	120,000	13.8
DO-41	240 x 100 x 90	5,000	410 x 335 x 265	60,000	20
DO-41G	96 x 80 x 42	1,000	410 x 335 x 265	60,000	20
FL	270 x 225 x 50	500	463 x 283 x 185	3,000	18.2
GBJ	352 x 337 x 44	600	375 x 360 x 213	2,400	25.4
GBL	350 x 337 x 44	960	375 x 360 x 213	3,840	13.1
GBP	350 x 337 x 44	1,120	375 x 360 x 213	4,480	10.7
GBPC	195 x 195 x 40	50	460 x 215 x 260	500	14.5
GBPCW	195 x 195 x 40	50	460 x 215 x 260	500	13
GBU	350 x 337 x 44	800	375 x 360 x 213	3,200	17
GL	195 x 195 x 40	80	460 x 215 x 260	800	11
GPJ	500 x 150 x 145	750	572 x 306 x 218	1,500	17
KBJ	219 x 177 x 44	200	367 x 232 x 250	2,000	16.3
KBPM	490 x 150 x 110	1,200	510 x 335 x 240	4,800	19
KBU	270 x 225 x 50	200	463 x 283 x 185	1,200	10
MDI	350 x 337 x 44	6,000	375 x 360 x 390	48,000	14.4
P-600	208 x 90 x 83	500	495 x 214 x 256	5,000	11.9
R-1	198 x 84 x 20	1,000	495 x 214 x 256	50,000	18.2
SDIP	-	-	495 x 214 x 256	24,000	16.8
TO / ITO-220	555 x 145 x 95	2,000	572 x 306 x 218	8,000	19
TO-251AB	560 x 210 x 79	8,400	572 x 306 x 218	33,600	22
TO-247AD	-	-	536 x 243 x 100	1,500	13.2
KBP	258x190x77	1,000	395x270x400	10,000	18.0
KBL	230x147x50	200	460x245x275	3,000	17.25
K3 / K6	210x115x90	200	600x235x198	2,000	7.3/8.8
K8	210x115x90	200	600x235x198	2,000	13.8
K10/K15/K25/K35/K50M	193x193x46	50	405x210x265	500	17.0
K10/K15/K25/K35/K50P	193x193x46	50	405x210x265	500	17.0
K10/K15/K25/K35/K50W	193x193x46	50	405x210x265	500	17.0





## Reel Packing

PACKAGE	REEL	COMPONENT SPACE	TAPE SPACE	REEL DIA	CARTON SIZE	CARTON	APPROX. GROSS WEIGHT
	(pcs)	(m/m)	(m/m)	(m/m)	(m/m)	(EA)	(Kg)
<b>Reel Packing</b>							
A-405	5,000	5	52	330	340 x 340 x 410	25,000	11.3
TO-263	800	16	24	330	375 x360 x 390	6,400	15
DO-15	4,000	5	52	330	340 x 340 x 410	20,000	11
DO-201AD	1,250	10	52	330	340 x 340 x 410	6,250	9.2
DO-201AE	1,250	10	52	330	340 x 340 x 410	6,250	9.2
DO-34	10,000	5	52	360	360 x 360 x 395	50,000	9.5
DO-35	10,000	5	52	360	360 x 360 x 395	50,000	12
DO-41	5,000	5	52	330	360 x 360 x 395	25,000	13
DO-41G	5,000	5	52	360	360 x 360 x 395	25,000	13
TO-252	3,000	8	16	330	375 x 360 x 390	42,000	20.2
MDI	3,000	8	12	330	375 x360 x 390	48,000	14.4
QUADRO-MELF	2,500	4	-	178	385 x 380 x 260	200,000	13.5
MELF/DL-41	5,000	4	-	330	350 x 350 x 300	100,000	14
MICRO-MELF	2,500	4	-	178	385 x 380 x 260	200,000	13.5
MINHMELF	10,000 / 2,500	4	-	330 / 178	360 x 360 x 395 / 385 x 380 x 260	200,000	14.0 / 13.5
P-600	800	10	52	330	340 x 340 x 410	4,000	11
QFN 1.6 x 1.6	4,000	4	8	178	390 x 240 x 420	200,000	7.8
R-1	5,000	5	52	330	340 x 340 x 410	25,000	6.3
SDIP	1,500	12	16	330	375 x360 x 390	21,000	16.3
SMA	7,500 / 1,800	4	12	330 / 178	375 x360 x 390 / 390 x 240 x 420	120,000 / 72,000	17.5 / 10
SMB	3,000 / 500	8	12	330 / 178	375 x360 x 390 / 390 x 240 x 420	48,000 / 20,000	13.6 / 7.5
SMC	3,000 / 500	12	16	330 / 178	375 x360 x 390 / 390 x 240 x 420	42,000 / 15,000	6.2 / 7.3
SOD-123	10,000 / 3,000	4	8	330 / 178	375 x 360 x 213 / 390 x 270 x 400	120,000 / 240,000	6.4 / 9.4
SOD-123FL	10,000 / 3,000	4	8	330 / 178	375 x 360 x 213 / 390 x 270 x 400	120,000 / 240,000	6.4 / 9.4
SOD-323	12,000 / 5,000	4	8	330 / 178	375 x 360 x 213 / 390 x 270 x 400	144,000 / 400,000	10 / 15.2
SOT-23	12,000 / 3,000	4	8	330 / 178	375 x 360 x 213 / 390 x 270 x 400	144,000 / 240,000	6.4 / 9.4
SOT-323	12,000 / 3,000	4	8	330 / 178	375 x 360 x 213 / 390 x 270 x 400	144,000 / 240,000	6.4 / 9.4
SOT-363	10,000 / 3,000	4	8	330 / 178	735 x 365 x 292 / 390 x 240 x 420	300,000 / 150,000	15.66 / 7.0
SOT-353	10,000 / 3,000	4	8	330 / 178	735 x 365 x 292 / 390 x 240 x 420	300,000 / 150,000	15.66 / 7.0
TO-92	2,000	-	-	335	390 x 390 x 280	8,000	6.067
SOD-523	12,000 / 5,000	4	8	330 / 178	375 x 360 x 213 / 390 x 270 x 400	144,000 / 400,000	10 / 15.2
QFN 2.0 x 2.0	5,000 / 3,000 / 1,000	4	8	330 / 178 / 178	553 x 365 x 358 / 333 x 240 x 257 / 333 x 240 x 257	45,000 / 39,000 / 13,000	4.5 / 3.0 / 2.5
SOT23-6L	3,000 / 2,500 / 1,000	4	8	330 / 178 / 178	553 x 365 x 358 / 333 x 240 x 257 / 333 x 240 x 257	39,000 / 32,500 / 13,000	3.0 / 3.0 / 2.5
SOIC-08	3,000 / 1,500 / 1,000	4	8	330 / 330 / 178	553 x 365 x 358 / 553 x 365 x 358 / 333 x 240 x 257	39,000 / 13,500 / 13,000	6.5 / 5.0 / 3.5



## Ammunition Packing

PACKAGE	AMMO (pcs)	COMPONENT SPACE (m/m)	TAPE SPACE (m/m)	BOX SIZE (m/m)	CARTON SIZE (m/m)	CARTON (EA)	APPROX. GROSS WEIGHT (Kg)
<b>Ammunition Packing</b>							
A-405	5,000	5	26	255 x 50 x 150	339 x 276 x 330	60,000	16.0
A-405	5,000	5	52	255 x 75 x 150	339 x 276 x 330	40,000	16.0
DO-15	3,000	5	52	255 x 75 x 150	339 x 276 x 330	24,000	11.9
DO-201AD	1,250	10	52	255 x 75 x 150	339 x 276 x 330	10,000	14.0
DO-201AE	1,250	10	52	255 x 75 x 150	339 x 276 x 330	10,000	14.0
DO-34	5,000	5	26	248 x 80 x 48	410 x 335 x 265	150,000	15.5
DO-34	5,000	5	52	248 x 80 x 75	410 x 335 x 265	100,000	14.1
DO-35	5,000	5	26	248 x 80 x 48	410 x 335 x 265	150,000	20.0
DO-35	5,000	5	52	248 x 80 x 75	410 x 335 x 265	100,000	15.7
DO-41	5,000	5	52	255 x 75 x 150	339 x 276 x 330	40,000	19.1
DO-41G	2,500	5	26	248 x 80 x 48	410 x 335 x 265	75,000	21.5
DO-41G	2,500	5	52	248 x 80 x 75	410 x 335 x 265	50,000	19.0
P-600	400	10	52	255 x 75 x 150	339 x 276 x 330	3,200	9.0
R-1	5,000	5	26	255 x 50 x 150	339 x 276 x 330	40,000	11.0
R-1	5,000	5	52	255 x 75 x 150	339 x 276 x 330	40,000	16.0



## 5. HIGH RELIABILITY TESTING SPEC.

NO	TEST ITEM	TEST CONDITION	REFERENCE DOCUMENT	LOT QUALITY LEVEL	REMARK
1	TEMPERATURE CYCLING (T.C.T)	Ta = -55 + 0, -3 °C 10min Ta = +150 +/- °C 10min FOR 20 CYCLE	MIL-STD-750D METHOD-1051.5	LTPD10 S.s. = 22 ACCEPT FOR 0 FAILURE ONLY.	
2	HIGH TEMPERATURE STORAGE LIFE (H.T.S.L)	Ta = 150 +/- 5 °C TESTING TIME: 168 HRS 250 HRS 500 HRS	MIL-STD-750D METHOD-1031.2	LTPD10 S.s. = 22 ACCEPT FOR 0 FAILURE ONLY.	
3	SOLDERABILITY TEST	TEMPERATURE OF SOLDER POT = 245 +/- 5 °C TIME FOR DIPPING FLUX = 5-10 SEC TIME FOR DIPPING IN SOLDER = 5 +/- 0.5 SEC DIPPING DEPTH = 0.05 inch max FOR ONE CYCLE	MIL-STD-750D	METHOD-2026.10 LTPD 7 S.s. = 32 ACCEPT FOR 0 FAILURE ONLY.	
4	HIGH TEMPERATURE REVERSE BIAS (H.T.R.B)	Ta = 150 +/- 5 °C VR = 80 % VR (CUSTOM SECP) TESTING TIME: 168 HRS 250 HRS 500 HRS	MIL-STD-750D METHOD-1038.3	LTPD10 S.s. = 22 ACCEPT FOR 0 FAILURE ONLY.	
5	CONTINUE FORWARD OPERATING LIFE (C.F.O.L)	Ta = 55 °C I = IO +/- 10 % TESTING TIME: 168 HRS 250 HRS 500 HRS	MIL-STD-750D METHOD-1027.3	LTPD10 S.s. = 22 ACCEPT FOR 0 FAILURE ONLY.	
6	THERMAL SHOCK (T.S.T)	HOT TANK T = 100 °C + 10 / -2 °C t = 5 min COLD TANK T = 0 °C + 2 / -10 °C t = 5 min 15 CYCLE TIME BETWEEN TRANSFERRING DO'NOT EXCEED 10 SECOND.	MIL-STD-750D METHOD-1056.7	LTPD10 S.s. = 22 ACCEPT FOR 0 FAILURE ONLY.	
7	PRESSURE COOKER (P.C.T)	Ta = 121 °C P = 1.2 kg / cm <sup>2</sup> TIME = 96 HRS	JEDEC JESD22-A102-C	LTPD10 S.s. = 22 ACCEPT FOR 0 FAILURE ONLY.	
8	INTERMITTENT FORWARD OPERATING LIFE (I.F.O.L)	I = Io x 1.0 POWER ON : 30 SEC POWER OFF : 50 SEC TESTING TIME: 2000 CYCLES	MIL-STD-750D METHOD 1036.3	LTPD10 S.s. = 22 ACCEPT FOR 0 FAILURE ONLY.	
9	FORWARD SURGE CURRENT (I.F.S.M)	SQ WAVE OR SINE WAVE IFSM=DATE SHEET SPEC. TIME = 8.3 Msec T = 1 CYCLE	MIL-STD-750D METHOD 4066.3	LTPD10 S.s. = 22 ACCEPT FOR 0 FAILURE ONLY.	
10	HUMIDITY	Ta = 85 °C RH = 85 % TESTING TIME: 168 HRS 250 HRS 500 HRS	MIL-STD-750D METHOD 1021.1	LTPD10 S.s. = 22 ACCEPT FOR 0 FAILURE ONLY.	
11	SOLDERABILITY RESISTANCE	TEMPERATURE OF SOLDER POT = 260 +/- 5 °C TIME FOR DIPPING IN SOLDER = 10 + 2 / -0 SEC DIPPING DEPTH = 1.57 +/- 0.79 mm BELOW BODY FOR ONE CYCLE	MIL-STD-750D METHOD 2031.1	LTPD10 S.s. = 22 ACCEPT FOR 0 FAILURE ONLY.	

\*SCHOTTKY PRODUCT TESTING TEMPERATURE 100 °C MAX (NORMAL)