



BAW56 / BAV70 / BAV99 / BAL99

SURFACE MOUNT SWITCHING DIODES

VOLTAGE 100 Volt **POWER** 250mWatt

SOT-23 Unit : inch(mm)

FEATURES

- Fast switching speed.
- Surface mount package ideally suited for automatic insertion
- Electrically identical to Standard JEDEC
- High Conductance
- Lead free in compliance with EU RoHS 2.0
- Green molding compound as per IEC 61249 standard

MECHANICAL DATA

- Case: SOT-23, Plastic
- Terminals: Solderable per MIL-STD-750, Method 2026
- Apporx. Weight: 0.0003 ounces, 0.0084 grams

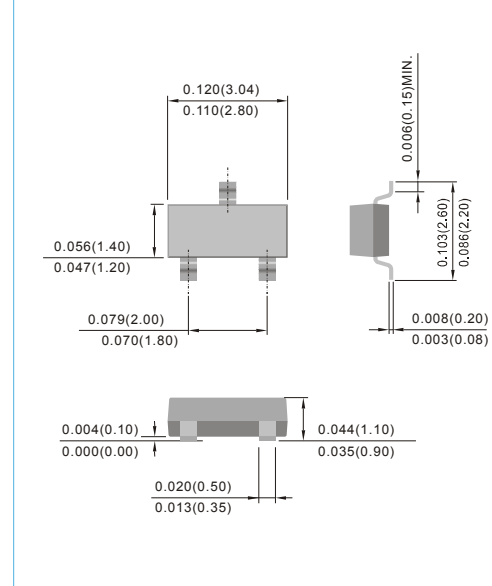

MAXIMUM RATINGS AND ELECTRICAL CHARACTERISTICS

Ratings at 25°C ambient temperature unless otherwise specified. For capacitive load, derate current by 20%.

PARAMETER	SYMBOL	BAW56	BAV70	BAV99	BAL99	UNITS
Marking Code	-	JC	JA	JB	JF	-
Reverse Voltage	V_R	75				V
Peak Reverse Voltage	V_{RM}	100				V
Rectified Current (Average), Half Wave Rectification with Resistive Load and $f \geq 50$ Hz	I_O	150				mA
Peak Forward Surge Current, 0.001ms	I_{FSM}	4.0				A
Power Dissipation Derate Above 25°C	P_{TOT}	250				mW
Maximum Forward Voltage	V_F	0.715 @ $I_F=1mA$ 0.855 @ $I_F=10mA$ 1.0 @ $I_F=50mA$ 1.25 @ $I_F=150mA$				V
Maximum DC Reverse Current at 25V 75V	I_R	0.03 2.5				μA
Maximum Junction Capacitance (Notes 1)	C_J	1.5				pF
Maximum Reverse Recovery Time (Notes 2)	t_{rr}	4.0				ns
Typical Thermal Resistance	$R_{\theta JA}$ $R_{\theta JC}$	360 205				$^{\circ}C / W$
Junction Temperature Range	T_J	-55 to +150				$^{\circ}C$
Circuit Figure	-	Common Anode	Common Cathode	Series	Single(Alt)	-

NOTE:

1. C_J at $V_R=0$, $f=1MHz$
2. From $I_F=10mA$ to $I_R=1mA$, $V_R=6Volts$, $R_L=100\Omega$

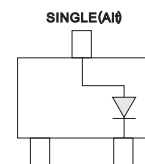
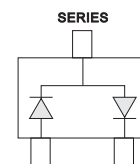
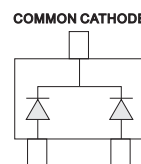
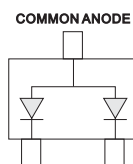



BAW56 / BAV70 / BAV99 / BAL99

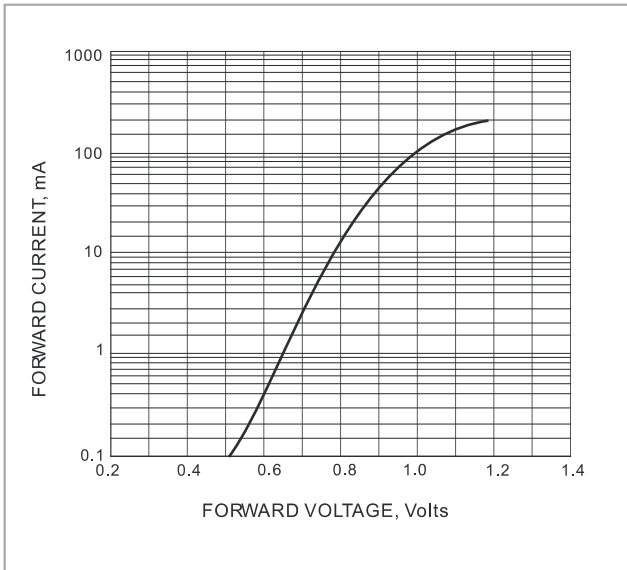

FIG. 1-TYPICAL FORWARD CHARACTERISTIC

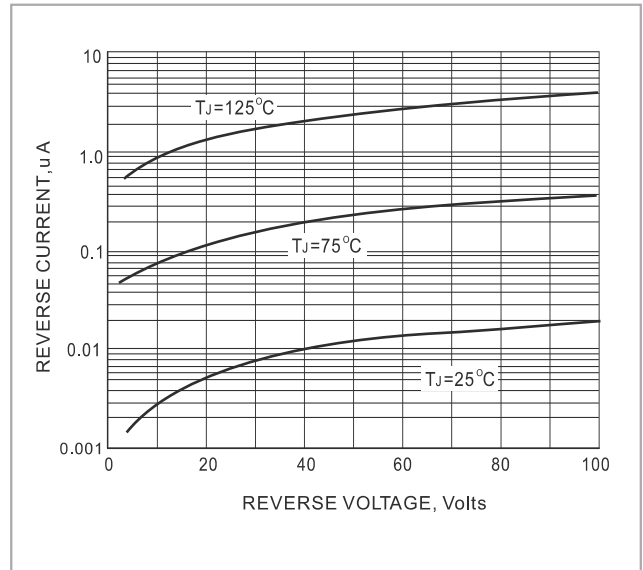

FIG. 2-TYPICAL REVERSE CHARACTERISTICS

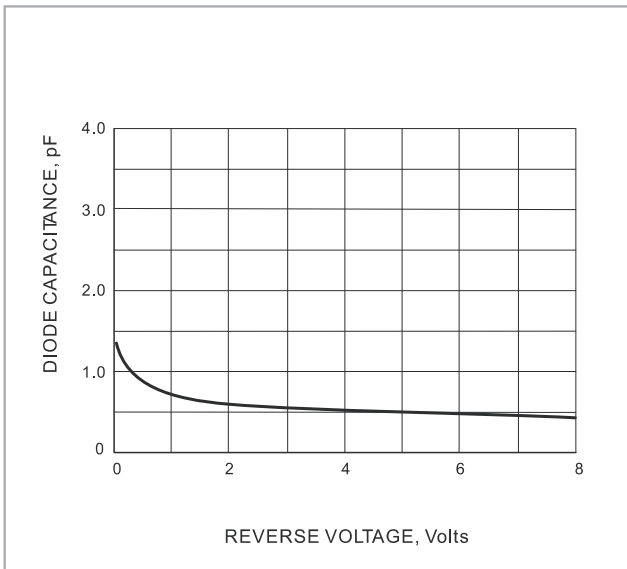

FIG. 3 TYPICAL JUNCTION CAPACITANCE

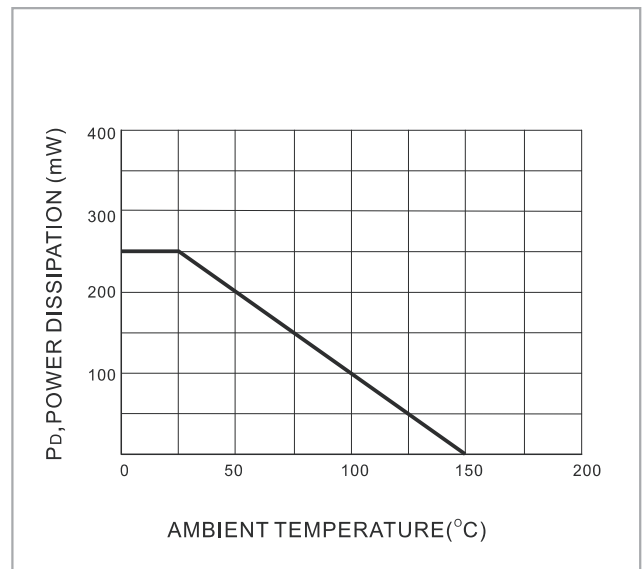

FIG. 4 POWER DERATING CURVE



BAW56 / BAV70 / BAV99 / BAL99

MOUNTING PAD LAYOUT

SOT-23

Unit : inch(mm)

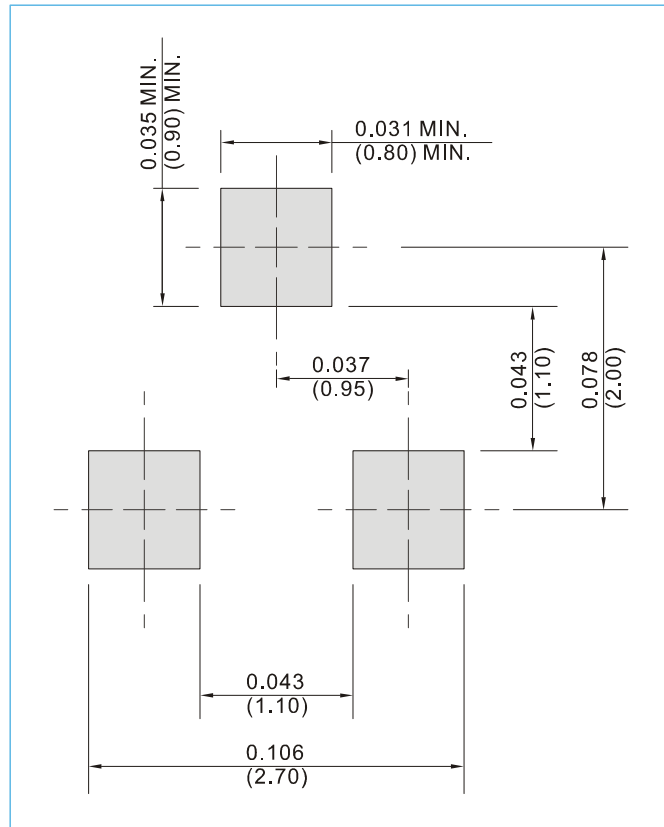

ORDER INFORMATION

- Packing information
 - T/R - 12K per 13" plastic Reel
 - T/R - 3K per 7" plastic Reel



BAW56 / BAV70 / BAV99 / BAL99

Part No_packing code_Version

BAW56_R1_00001

BAW56_R2_00001

For example :

RB500V-40_R2_00001

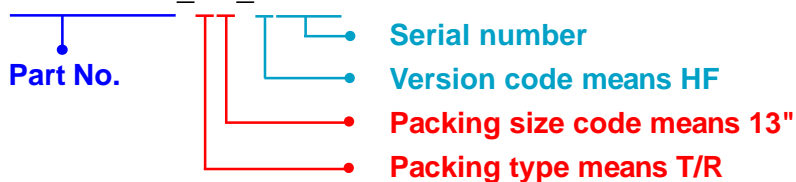

Packing Code XX				Version Code XXXXX		
Packing type	1 st Code	Packing size code	2 nd Code	HF or RoHS	1 st Code	2 nd ~5 th Code
Tape and Ammunition Box (T/B)	A	N/A	0	HF	0	serial number
Tape and Reel (T/R)	R	7"	1	RoHS	1	serial number
Bulk Packing (B/P)	B	13"	2			
Tube Packing (T/P)	T	26mm	X			
Tape and Reel (Right Oriented) (TRR)	S	52mm	Y			
Tape and Reel (Left Oriented) (TRL)	L	PANASERT T/B CATHODE UP (PBCU)	U			
FORMING	F	PANASERT T/B CATHODE DOWN (PBCD)	D			



BAW56 / BAV70 / BAV99 / BAL99

Disclaimer

- Reproducing and modifying information of the document is prohibited without permission from Panjit International Inc..
- Panjit International Inc. reserves the rights to make changes of the content herein the document anytime without notification. Please refer to our website for the latest document.
- Panjit International Inc. disclaims any and all liability arising out of the application or use of any product including damages incidentally and consequentially occurred.
- Panjit International Inc. does not assume any and all implied warranties, including warranties of fitness for particular purpose, non-infringement and merchantability.
- Applications shown on the herein document are examples of standard use and operation. Customers are responsible in comprehending the suitable use in particular applications. Panjit International Inc. makes no representation or warranty that such applications will be suitable for the specified use without further testing or modification.
- The products shown herein are not designed and authorized for equipments requiring high level of reliability or relating to human life and for any applications concerning life-saving or life-sustaining, such as medical instruments, transportation equipment, aerospace machinery et cetera. Customers using or selling these products for use in such applications do so at their own risk and agree to fully indemnify Panjit International Inc. for any damages resulting from such improper use or sale.
- Since Panjit uses lot number as the tracking base, please provide the lot number for tracking when complaining.