



TABLE OF CONTENTS

1.DATA SHEET PAGE 1

2.MARKING PAGE 4

3.TAPING PAGE 5

4.PACKING PAGE 6

5.HIGH RELIABILITY TESTING SPEC. PAGE 9



1.DATA SHEET

BAV99

SURFACE MOUNT SWITCHING DIODES

VOLTAGE 75 Volts **POWER** 250mWatts

SOT-23 Unit: inch (mm)

FEATURES

- Fast switching speed.
- Surface mount package Ideally Suited for Automatic insertion
- Electrically Identical to Standard JEDEC
- High Conductance
- Both normal and Pb free product are available :
- Normal : 80~95 %Sn, 5~20 % Pb
- Pb free : 99% Sn above can meet Rohs environment substance directive request

MECHANICAL DATA

Case: SOT-23, Plastic
 Terminals: Solderable per MIL-STD-202G, Method 208
 Approx. Weight: 8mg
 Marking Code: JG

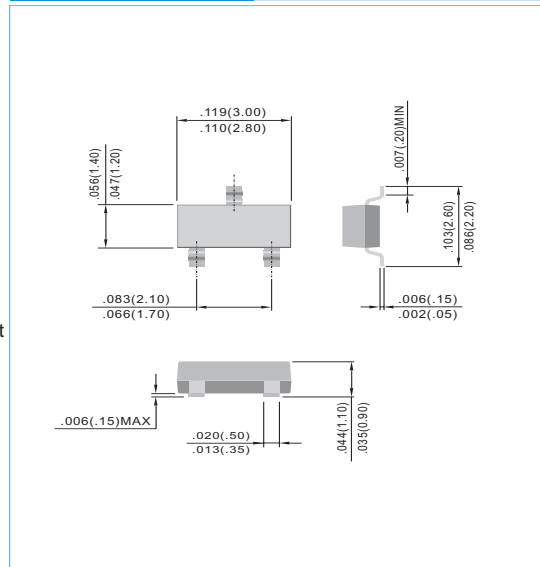

MAXIMUM RATINGS AND ELECTRICAL CHARACTERISTICS

Ratings at 25°C ambient temperature unless otherwise specified. For capacitive load, derate current by 20%.

PARAMETER	SYMBOL	BAV99	UNITS
Reverse Voltage	V_R	75	V
Peak Reverse Voltage	V_{RM}	100	V
Rectified Current (Average), Half Wave Rectification with Resistive Load and $f \geq 50$ Hz	I_o	150	mA
Peak Forward Surge Current, 1.0us	I_{FSM}	2.0	A
Power Dissipation Derate Above 25°C	P_{TOT}	250	mW
Maximum Forward Voltage	V_F	0.715 @ $I_F=0.001A$ 0.855 @ $I_F=0.01A$ 1.0 @ $I_F=0.05A$ 1.25 @ $I_F=0.15A$	V
Maximum DC Reverse Current at 25V 75V	I_R	0.03 2.5	μA
Maximum Junction Capacitance(Notes 1)	C_J	1.5	pF
Maximum Reverse Recovery Time (Notes 2)	T_{RR}	4.0	ns
Maximum Thermal Resistance	$R_{\theta JA}$	625	°C / W
Junction Temperature Range	T_J	-55 TO +150	°C

NOTE:

1. C_J at $V_R=0$, $f=1MHz$
2. From $I_F=10mA$ to $I_R=1mA$, $V_R=6Volts$, $R_L=100\Omega$

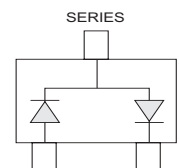

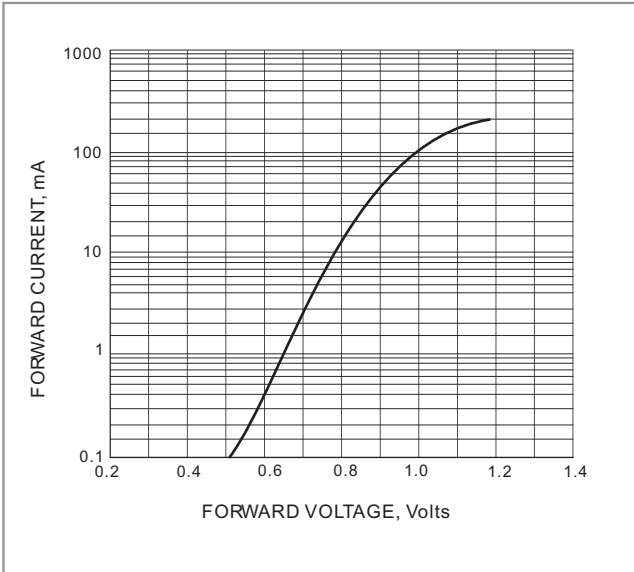

FIG. 1-TYPICAL FORWARD CHARACTERISTIC

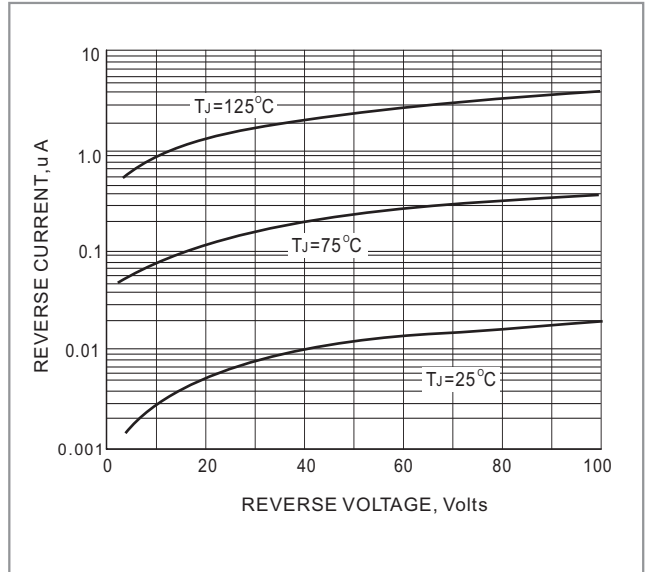

FIG. 2-TYPICAL REVERSE CHARACTERISTICS

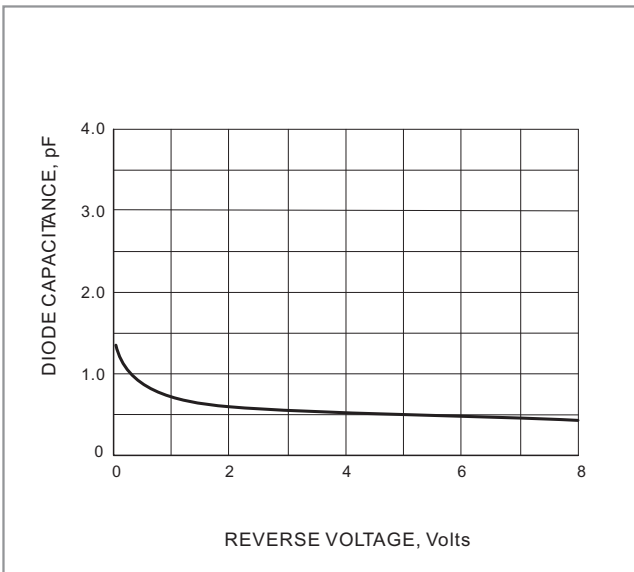

FIG. 3 TYPICAL JUNCTION CAPACITANCE

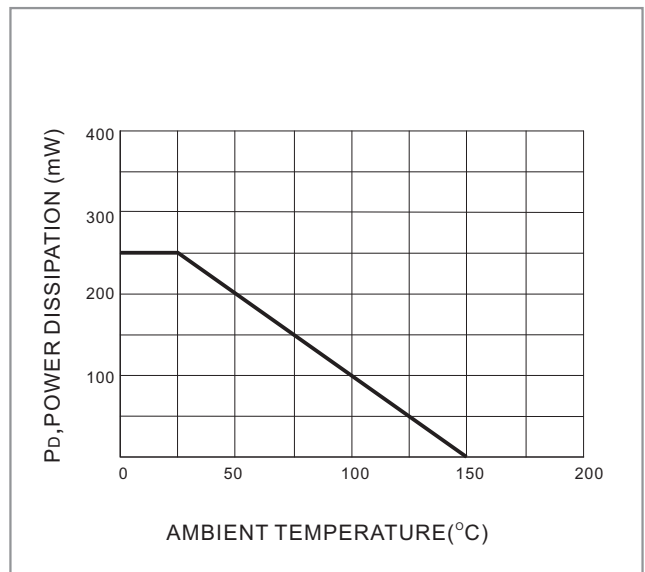
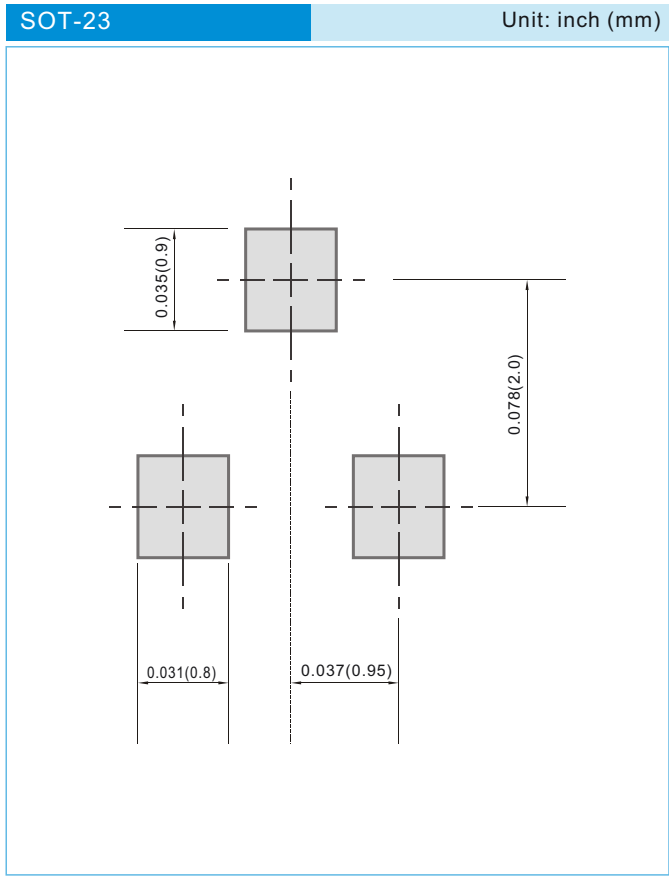

FIG. 4 POWER DERATING CURVE



MOUNTING PAD LAYOUT



ORDER INFORMATION

- Packing information
 - T/R - 12K per 13" plastic Reel
 - T/R - 3.0K per 7" plastic Reel

LEGAL STATEMENT

IMPORTANT NOTICE

This information is intended to unambiguously characterize the product in order to facilitate the customer's evaluation of the device in the application. The information will help the customer's technical experts determine that the device is compatible and interchangeable with similar devices made by other vendors. The information in this data sheet is believed to be reliable and accurate. The specifications and information herein are subject to change without notice. New products and improvements in products and product characterization are constantly in process. Therefore, the factory should be consulted for the most recent information and for any special characteristics not described or specified.

Copyright Pan Jit International Inc. 2003

All rights reserved. Reproduction in whole or in part is prohibited without the prior written consent of the copyright owner.

The information presented in this document does not form part of any quotation or contract. The information presented is believed to be accurate and reliable, and may change without notice in advance. No liability will be accepted by the publisher for any consequence of use. Publication thereof does not convey nor imply any license under patent or other industrial or intellectual property rights.



2. MARKING

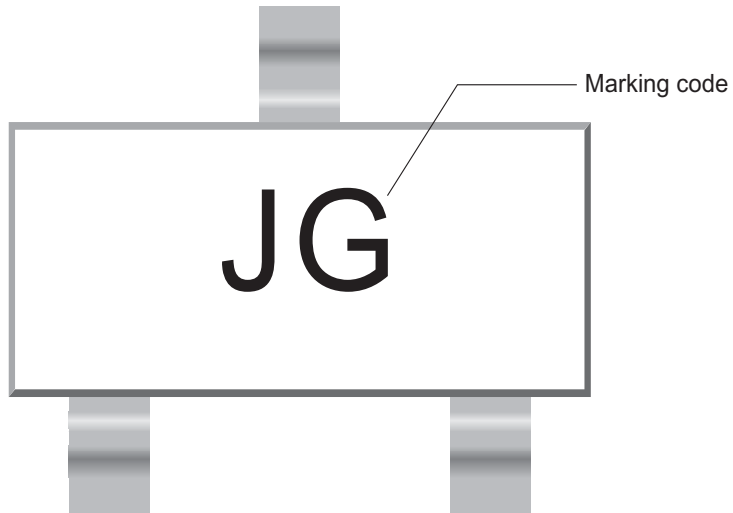



3. TAPING

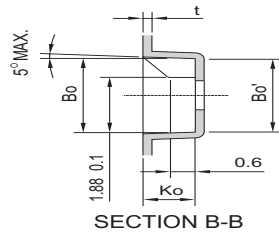
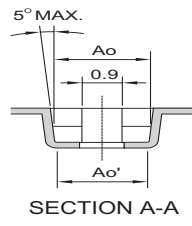
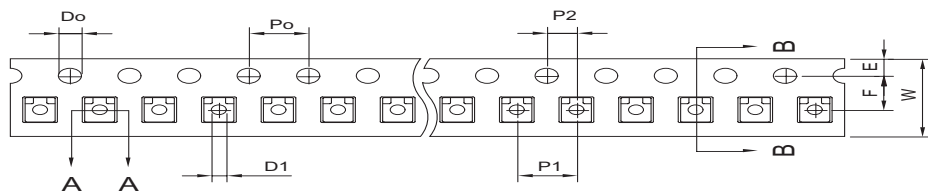
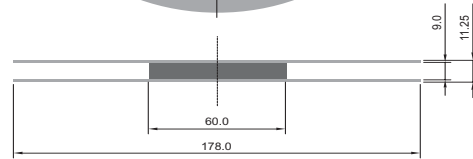
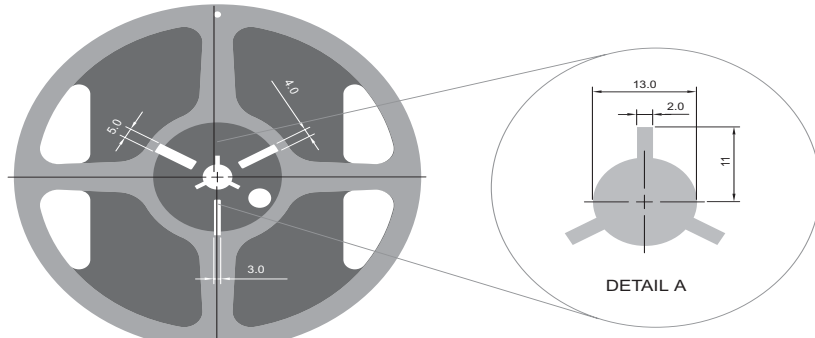

SYMBOL	mm (INCH)
TYPE SIZE 8.00 (0.314)	
Ao	3.15 ± 0.10(0.124 ± 0.004)
Bo	2.65 ± 0.10(0.104 ± 0.004)
Do	1.55 ± 0.05(0.610 ± 0.002)
D1	1.00 ± 0.10(0.039 ± 0.004)
E	1.75 ± 0.10(0.069 ± 0.004)
F	3.50 ± 0.05(0.137 ± 0.002)
Ko	1.17 ± 0.10(0.046 ± 0.004)
Po	4.00 ± 0.10(0.157 ± 0.004)
P1	4.00 ± 0.10(0.157 ± 0.004)
P2	2.00 ± 0.05(0.009 ± 0.002)
t	0.20 ± 0.05(0.008 ± 0.002)
W	8.00 ± 0.30(0.314 ± 0.012)
Ao'	3.00 ± 0.10(0.118 ± 0.004)
Bo'	2.55 ± 0.10(0.100 ± 0.004)

- NOTE:
1. There shall be leader of 230 mm minimum which may consist of carrier and or cover tape follower by a minimum of 160 mm of carrier tape sealed with cover tape.
 2. There shall e minimum of 160 mm of empty component pockets sealed with cover tape.
 3. Devices are packed in accordance whit EIA standard EIA-481-A and specifications given above.



4. PACKING

REEL PACKING

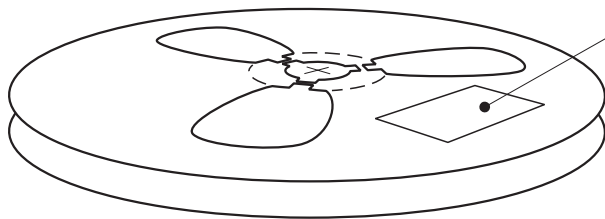

Quantity per Reel: 3,000 pcs

LABEL TYPE

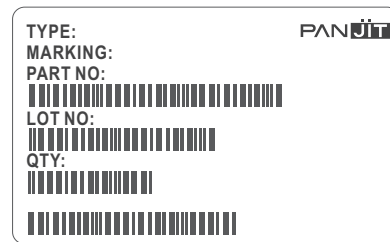

CARTON

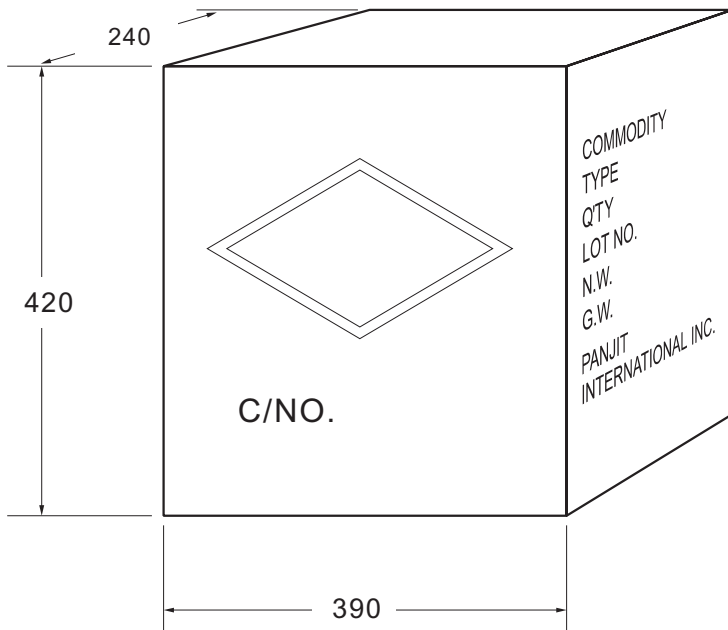

Box Dimensions : mm
Quantity per Box: 150,000pcs

SHIPPING MARK

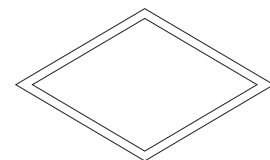

C/NO.
PRODUCT COUNTRY

SIDE MARK

COMMODITY:
TYPE:
Q'TY:
LOT NO.
N.W.
G.W.
PANJIT
INTERNATIONAL INC.



Bulk Packing

PACKAGE	INNER SIZE	BOX	CARTON SIZE	CARTON	APPROX. GROSS WEIGHT
	(m/m)	(EA)	(m/m)	(EA)	(Kg)
Bulk Packing					
R-1	198 x 84 x 20	1,000	459 x 214 x 256	50,000	12.4
A-405	198 x 84 x 20	1,000	459 x 214 x 256	50,000	13.4
DO-35	96 x 80 x 42	10,000	410 x 350 x 275	120,000	21.5
DO-41G	240 x 100 x 100	5,000	410 x 350 x 275	60,000	26.5
DO-41	198 x 84 x 20	1,000	459 x 214 x 256	50,000	19.1
DO-15	200 x 85 x 25	1,000	459 x 214 x 256	40,000	17.5
DO-201AE	200 x 85 x 40	500	459 x 214 x 256	12,500	17.0
DO-201AD	200 x 85 x 40	500	459 x 214 x 256	12,500	17.3
P600	208 x 90 x 83	500	459 x 214 x 256	5,000	11.3
AM	195 x 195 x 40	1,000	400 x 273 x 415	10,000	16.8
DIP	-	-	459 x 214 x 256	12,000	10.2
SDIP	-	-	459 x 214 x 256	24,000	15.5
FL	230 x 230 x 50	500	495 x 245 x 180	3,000	25.0
GBU	350 x 337 x 44	800	510 x 340 x 235	3,200	18.9
ITO/TO-220	555 x 145 x 95	2,000	570 x 306 x 218	8,000	13.4
GL	260 x 190 x 75	72	460 x 215 x 260	864	15.8
KBU	230 x 230 x 50	200	495 x 245 x 180	3,000	21.5
GBJ	352 x 337 x 44	600	375 x 360 x 213	2,400	13.1
TO-251AB	560 x 210 x 79	8,000	577 x 226 x 196	16,000	6.5
GBL	352 x 337 x 44	960	375 x 360 x 213	3,840	13.0
GBP	352 x 337 x 44	1,120	375 x 360 x 213	4,480	11.3
TO-3P	-	-	536 x 243 x 100	1,500	12.7
GBPC/W	195 x 195 x 41	50	460 x 215 x 260	500	9.8 / 8.8

Ammunition Packing

PACKAGE	AMMO	COMPONENT SPACE	TAPE SPACE	BOX SIZE	CARTON	CARTON	APPROX. GROSS WEIGHT
	(PCS)	(m/m)	(m/m)	(m/m)	(m/m)	(E/A)	(Kg)
Ammunition Packing							
R-1	5,000	5.0	26	255 x 50 x 150	339 x 276 x 330	60,000	12.4
R-1	5,000	5.0	52	255 x 75 x 150	339 x 276 x 330	40,000	12.4
A-405	5,000	5.0	26	255 x 50 x 150	339 x 276 x 330	60,000	13.4
A-405	5,000	5.0	52	255 x 75 x 150	339 x 276 x 330	40,000	13.4
DO-35	5,000	5.0	52	255 x 80 x 80	410 x 350 x 275	100,000	20.0
DO-41G	2,500	5.0	52	255 x 80 x 80	410 x 350 x 275	50,000	22.0
DO-41	5,000	5.0	52	255 x 75 x 150	339 x 276 x 330	40,000	19.1
DO-15	3,000	5.0	52	255 x 75 x 150	339 x 276 x 330	24,000	17.5
DO-201AE	1,250	10.0	52	255 x 75 x 150	339 x 276 x 330	10,000	17.0
DO-201AD	1,250	10.0	52	255 x 75 x 150	339 x 276 x 330	10,000	17.3
P600	400	10.0	52	255 x 75 x 150	339 x 276 x 330	3,200	11.3



Reel Packing

PACKAGE	REEL	COMPONENT SPACE	TAPE SPACE	REEL DIA	CARTON SIZE	CARTON	APPROX. GROSS WEIGHT
	(pcs)	(m/m)	(m/m)	(EA)	(EA)	(EA)	(Kg)
Reel Packing							
R-1	5,000	5.0	52	330	340 x 340 x 410	25,000	9.0
A-405	5,000	5.0	52	330	340 x 340 x 410	25,000	9.1
DO-35	10,000	5.0	52	360	380 x 380 x 420	50,000	13.0
DO-41G	5,000	5.0	52	360	380 x 380 x 420	25,000	14.5
DO-41	5,000	5.0	52	330	340 x 340 x 410	25,000	12.4
DO-15	4,000	5.0	52	330	340 x 340 x 410	20,000	11.8
DO-201AE	1,250	10.0	52	330	340 x 340 x 410	6,250	11.0
DO-201AD	1,250	10.0	52	330	340 x 340 x 410	6,250	11.6
P600	800	10.0	52	330	340 x 340 x 410	4,000	11.4
SMA	7,500 / 1,800	4.0	-	330 / 178	375 x 360 x 390 / 390 x 240 x 420	120,000 / 72,000	17.5 / 8.3
SMB	3,000 / 500	4.0	-	330 / 178	375 x 360 x 390 / 390 x 240 x 420	48,000 / 20,000	13.6 / 7.5
SMC	3,000 / 500	12.0	-	330 / 178	375 x 360 x 390 / 390 x 240 x 420	42,000 / 15,000	16.2 / 7.3
SDIP	1,500	12.0	-	330	375 x 360 x 390	21,000	16.3
MDI	3,000 / 500	8.0	-	330 / 178	375 x 360 x 390	48,000 / 30,000	14.4
D ² PCK	800	16.0	-	330	375 x 360 x 390	6,400	15.6
TO-252	3,000	8.0	-	330 / 178	375 x 360 x 390	42,000	16.5
SOD-123	10,000 / 3,000	4.0	-	330 / 178	375 x 360 x 213 / 390 x 240 x 420	120,000 / 150,000	8.0 / 10.0
SOD-323	12,000 / 5,000	4.0	-	330 / 178	375 x 360 x 213 / 390 x 240 x 420	144,000 / 250,000	9.6 / 10.0
SOT-23	12,000 / 3,000	4.0	-	330 / 178	375 x 360 x 213 / 390 x 240 x 420	144,000 / 150,000	9.6 / 10.0
SOT-323	12,000 / 3,000	4.0	-	330 / 178	375 x 360 x 213 / 390 x 240 x 420	144,000 / 150,000	9.6 / 10.0
SOT-363	3,000	4.0	-	178	438 x 438 x 220	120,000	-
SOT-23-6L	3,000	4.0	-	178	438 x 438 x 220	120,000	-
MICRO-MELF	2,500	4.0	-	178	640 x 405 x 150	200,000	15.7
QUADRO-MELF	2,500	4.0	-	178	640 x 405 x 150	200,000	15.7
MINI-MELF	2,500	4.0	-	178	640 x 405 x 150	200,000	15.7
DL-41	5,000	4.0	-	330	350 x 350 x 350	100,000	22.0



5. HIGH RELIABILITY TESTING SPEC.

NO	TEST ITEM	TEST CONDITION	REFERENCE DOCUMENT	LOT QUALITY LEVEL	REMARK
1	TEMPERATURE CYCLING (T.C.T)	Ta= -55+0,-3°C 10min Ta= +150+/-°C 10min FOR 20 CYCLE	MIL - STD - 750D METHOD - 1051.5	LTPD 10 S.s.=22 ACCEPT FOR 0 FAILURE ONLY.	
2	HIGH TEMPERATURE STORAGE LIFE (H.T.S.L)	Ta=150 +/- 5°C TESTING TIME: 168HRS 250HRS 500HRS	MIL-STD-750D METHOD-1031.2	LTPD10 S.s.=22 ACCEPT FOR 0 FAILURE ONLY.	
3	SOLDERABILITY TEST	TEMPERATURE OF SOLDER POT=260 +/- 5 TIME FOR DIPPING FLUX=5-10SEC TIME FOR DIPPING IN SOLDER=5+/-0. 5SEC DIPPING DEPTH=0.05 inch max FOR ONE CYCLE	MIL-STD-750D	METHOD-2026.10 LTPD 7 S.s.=32 ACCEPT FOR 0 FAILURE ONLY.	
4	HIGH TEMPERATURE REVERSE BIAS (H.T.R.B)	Ta=150 +/- 5°C VR=80%VR(CUSTOM SECP) TESTING TIME: 48HRS 96HRS 168HRS 250HRS 500HRS	MIL-STD-750D METHOD-1038.3	LTPD10 S.s.=22 ACCEPT FOR 0 FAILURE ONLY.	
5	CONTINUE FORWARD OPERATING LIFE (C.F.O.L)	Ta=55 °C I=IO +/-10% TESTING TIME: 168HRS 250HRS 500HRS	MIL-STD-750D METHOD-1027.3	LTPD10 S.s.=22 ACCEPT FOR 0 FAILURE ONLY.	
6	THERMAL SHOCK (T.S.T)	HOT TANK T=100°C+10/-2°C t=5min COLD TANK T=0°C+2/-10°C t=5min 15 CYCLE TIME BETWEEN TRANSFERRING DO'NOT EXCEED 10 SECOND.	MIL-STD-750D METHOD-1056.7	LTPD10 S.s.=22 ACCEPT FOR 0 FAILURE ONLY.	
7	PRESSURE COOKER (P.C.T)	Ta=121°C P=1.2kg/cm ² TIME=96HRS	JEDEC JESD22-A102-C	LTPD10 S.s.=22 ACCEPT FOR 0 FAILURE ONLY.	
8	INTERMITTENT FORWARD OPERATING LIFE (I.F.O.L)	I = Io x 1.0 POWER ON : 30SEC POWER OFF : 50SEC TESTING TIME: 2000 CYCLES	MIL-STD-750D METHOD 1036.3	LTPD10 S.s.=22 ACCEPT FOR 0 FAILURE ONLY.	
9	FORWARD SURGE CURRENT (I.F.S.M)	SQ WAVE OR SINE WAVE IFSM=DATE SHEET SPEC. TIME=8.3Msec T=1 CYCLE	MIL-STD-750D METHOD 4066.3	LTPD10 S.s.=22 ACCEPT FOR 0 FAILURE ONLY.	
10	HUMIDITY	Ta=85°C RH=85% TESTING TIME: 168HRS 250HRS 500HRS	MIL-STD-750D METHOD 1021.1	LTPD10 S.s.=22 ACCEPT FOR 0 FAILURE ONLY.	
11	SOLDERABILITY RESISTANCE	TEMPERATURE OF SOLDER POT =260+/-5°C TIME FOR DIPPING IN SOLDER =10+2/-0 SEC DIPPING DEPTH=1.57+0.79 mm BELOW BODY FOR ONE CYCLE	MIL-STD-750D METHOD 2031.1	LTPD10 S.s.=22 ACCEPT FOR 0 FAILURE ONLY.	

SCHOTTKY PRODUCT TESTING TEMPERATURE 125 °C MAX(NORMAL)