



**TABLE OF CONTENTS**

1.DATA SHEET PAGE 1

2.MARKING PAGE 3

3.PACKING PAGE 4



# AM150~AM1510

## 1.5 AMPERE SILICON MINIATURE SINGLE-PHASE BRIDGES

**VOLTAGE** 50 to 600 Volts **CURRENT** 1.5 Amperes

**Reconnized File # E111753**

### FEATURES

- Ratings to 1000V PRV
- Surge overload rating: 30 Amperes peak
- Ideal for printed circuit board
- Reliable low cost construction utilizing molded plastic technique
- Mounting position: Any
- Pb free product are available : 99% Sn above can meet RoHS environment substance directive request

### MECHANICAL DATA

Case: Reliable low cost construction utilizing molded plastic technique results in inexpensive product.  
 Terminals: Leads solderable per MIL-STD-750, Method 2026  
 Polarity : Polarity symbols marking on body.  
 Weight: 0.05 ounce, 1.3 grams

AM Unit: inch (mm)

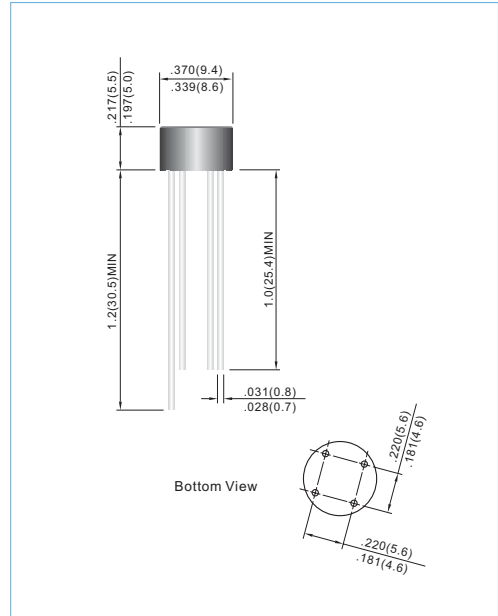

### MAXIMUM RATINGS AND ELECTRICAL CHARACTERISTICS

Rating at 25°C ambient temperature unless otherwise specified. Resistive or inductive load, 60Hz.  
 For Capacitive load derate current by 20%.

PARAMETER	SYMBOL	AM150	AM151	AM152	AM154	AM156	AM158	AM1510	UNITS
Maximum Recurrent Peak Reverse Voltage	$V_{RRM}$	50	100	200	400	600	800	1000	V
Maximum RMS Bridge Input Voltage	$V_{RMS}$	35	70	140	280	420	560	700	V
Maximum DC Blocking Voltage	$V_{DC}$	50	100	200	400	600	800	1000	V
Maximum Average Forward Current $T_A=50^\circ\text{C}$	$I_{F(AV)}$	1.5							A
Peak Forward Surge Current: 8.3ms single half sine-wave superimposed on rated load (JEDEC method)	$I_{FSM}$	50							A
$I^2t$ Rating for fusing ( $t < 8.35\text{ms}$ )	$I^2t$	10							A <sup>2</sup> t
Maximum Forward Voltage Drop per Bridge Element at 1.0A	$V_F$	1.0							V
Maximum DC Reverse Current at Rated DC Blocking Voltage	$I_R$	10 @ $T_A=25^\circ\text{C}$ 1000 @ $T_A=100^\circ\text{C}$							$\mu\text{A}$
Typical Junction capacitance (Note 1)	$C_j$	24							pF
Typical thermal resistance per leg ((Note 2)	$R_{\theta JA}$	36							$^\circ\text{C} / \text{W}$
Typical thermal resistance per leg ((Note 2)	$R_{\theta JL}$	13							
Operating and Storage Temperature Range	$T_j$	-55 to + 125							$^\circ\text{C}$
Storage Temperature Range	$T_{STG}$	-55 to + 150							$^\circ\text{C}$

NOTES:

1. Measured at 1.0 MHz and applied reverse voltage of 4.0 Volts.
2. Thermal resistance from junction to ambient and from junction to lead mounted on P.C.B. with 0.47 X 0.47"(12 X 12mm) copper pads.



# AM150~AM1510

## RATING AND CHARACTERISTIC CURVES

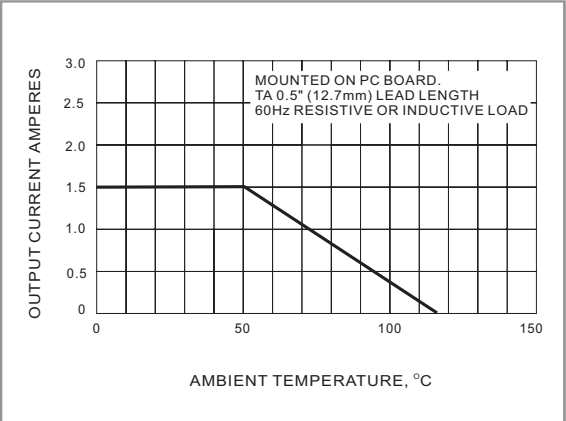

**FIG.1 DERATING CURVE FOR OUTPUT RECTIFIED CURRENT**

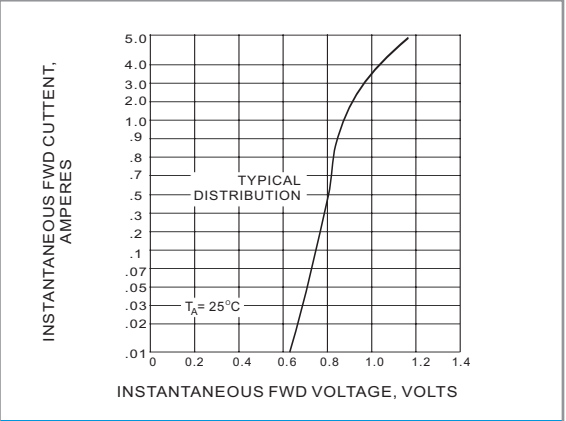

**FIG.2 TYPICAL FORWARD CHARACTERISTICS**

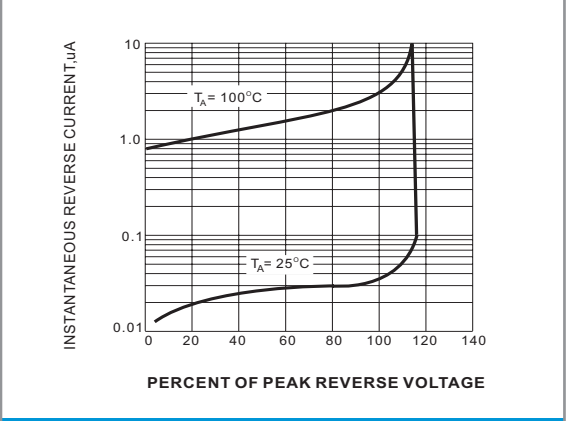

**FIG.3 TYPICAL REVERSE CHARACTERISTICS**

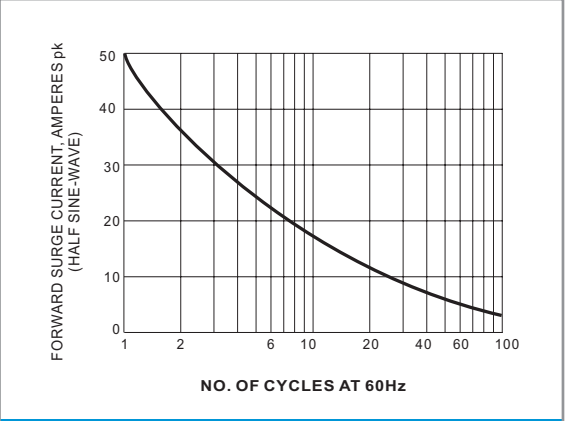

**FIG.4 MAX NON-REPETITIVE SURGE CURRENT**



## 2. MARKING

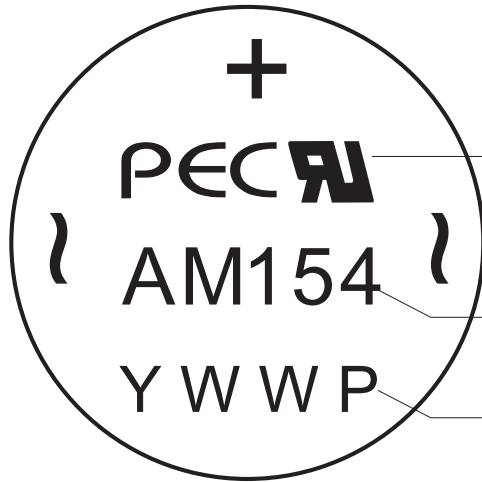

1nd line: PEC PanJit logo

2nd line: Marking code

3rd line: Y- Last digit of calendar year  
WW-Weekly  
P- Production line



### 3. PACKING

#### BULK PACKING

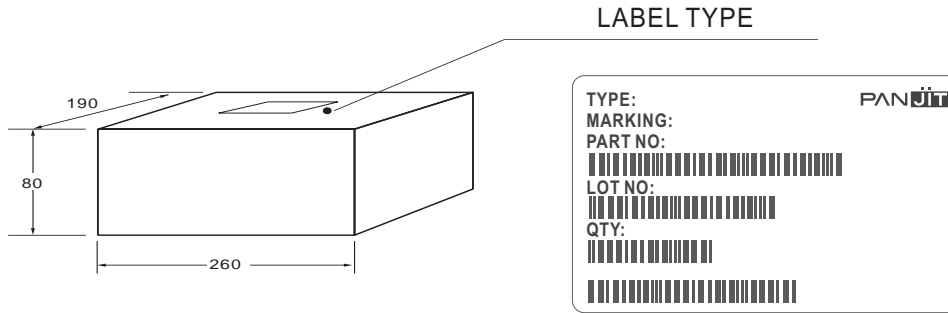

Box Dimensions : mm  
Quantity per Box : 1,000pcs

#### CARTON

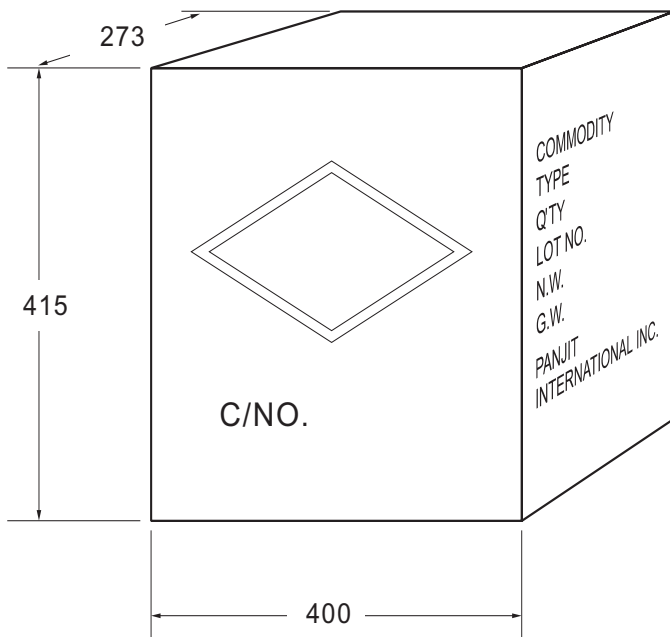

Box Dimensions : mm  
Quantity per Box : 10,000pcs

#### SHIPPING MARK

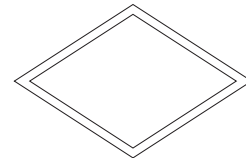

C/NO.  
PRODUCT COUNTRY

#### SIDE MARK

COMMODITY:  
TYPE:  
Q'TY:  
LOT NO.  
N.W.  
G.W.  
PANJIT  
INTERNATIONAL INC.



## Bulk Packing

PACKAGE	INNER SIZE	BOX	CARTON SIZE	CARTON	APPROX. GROSS WEIGHT
	(m/m)	(EA)	(m/m)	(EA)	(Kg)
<b>Bulk Packing</b>					
A-405	198 x 84 x 20	10,000	459 x 214 x 256	50,000	18.2
AM	260 x 190 x 80	1,000	400 x 273 x 415	10,000	15
CM / W	195 x 195 x 40	50	460 x 215 x 260	500	18
CP-15 / 25 / 35	195 x 195 x 40	50	460 x 215 x 260	500	11
CP-3 / 6	260 x 190 x 80	400	400 x 273 x 415	4,000	8.5
CP-8 / 10	260 x 190 x 80	250	400 x 273 x 415	2,500	14
DIP	-	-	495 x 214 x 256	12,000	8.8
DO-15	200 x 85 x 25	1,000	459 x 214 x 256	40,000	17
DO-201AD	200 x 85 x 40	500	495 x 214 x 256	12,500	15.8
DO-201AE	200 x 85 x 40	500	495 x 214 x 256	12,500	15.8
DO-34	96 x 80 x 42	2,000	410 x 335 x 265	120,000	12
DO-35	96 x 80 x 42	2,000	410 x 335 x 265	120,000	13.8
DO-41	240 x 100 x 90	5,000	410 x 335 x 265	60,000	20
DO-41G	96 x 80 x 42	1,000	410 x 335 x 265	60,000	20
FI	208 x 90 x 83	500	490 x 225 x 380	10,000	20.4
FL	270 x 225 x 50	500	463 x 283 x 185	3,000	18.2
GBJ	352 x 337 x 44	800	375 x 360 x 213	3,200	25.4
GBL	350 x 337 x 44	960	375 x 360 x 213	3,840	13.1
GBP	350 x 337 x 44	1,120	375 x 360 x 213	4,480	10.7
GBPC	195 x 195 x 40	50	460 x 215 x 260	500	12
GBPCW	195 x 195 x 40	50	460 x 215 x 260	500	18
GBU	350 x 337 x 44	800	375 x 360 x 213	3,200	17
GL	195 x 195 x 40	80	460 x 215 x 260	800	11
GPJ	500 x 150 x 145	750	572 x 306 x 218	1,500	17
KBJ	219 x 177 x 44	200	367 x 232 x 250	2,000	16.3
KBPC / W	195 x 195 x 40	50	460 x 215 x 260	500	18
KBPM	490 x 150 x 110	1,200	510 x 335 x 240	4,800	19
KBU	270 x 225 x 50	200	463 x 283 x 185	1,200	10
MDI	350 x 337 x 44	6,000	375 x 360 x 390	48,000	14.4
P-600	208 x 90 x 83	500	495 x 214 x 256	5,000	11.9
R-1	198 x 84 x 20	1,000	495 x 214 x 256	50,000	18.2
SDIP	-	-	495 x 214 x 256	24,000	16.8
TO / ITO-220	555 x 145 x 95	2,000	572 x 306 x 218	8,000	19
TO-251AB	560 x 210 x 79	8,400	572 x 306 x 218	33,600	22
TO-247AD	-	-	536 x 243 x 100	1,500	13.2
RB/WOB	258x190x77	1,000	395x270x400	10,000	15.0/17.0
KBP	258x190x77	1,000	395x270x400	10,000	18.0
KBL	230x147x50	200	460x245x275	3,000	17.25
K3/K6	210x115x90	200	600x235x198	2,000	7.3/8.8
K8	210x115x90	200	600x235x198	2,000	13.8
K10/K15/K25/K35/K50M	193x193x46	50	405x210x265	500	17.0
K10/K15/K25/K35/K50P	193x193x46	50	405x210x265	500	12.0
K10/K15/K25/K35/K50W	193x193x46	50	405x210x265	500	17.0



## Reel Packing

PACKAGE	REEL	COMPONENT SPACE	TAPE SPACE	REEL DIA	CARTON SIZE	CARTON	APPROX. GROSS WEIGHT
	(pcs)	(m/m)	(m/m)	(m/m)	(m/m)	(EA)	(Kg)
<b>Reel Packing</b>							
A-405	5,000	5.0	52	330	340 x 340 x 410	25,000	11.3
TO-263	2,500	8.0	24	330	375 x360 x 390	35,000	18
DO-15	4,000	5.0	52	330	340 x 340 x 410	20,000	11
DO-201AD	1,250	10.0	52	330	340 x 340 x 410	6,250	9.2
DO-201AE	1,250	10.0	52	330	340 x 340 x 410	6,250	9.2
DO-34	10,000	5.0	52	360	360 x 360 x 395	50,000	9.5
DO-35	10,000	5.0	52	360	360 x 360 x 395	50,000	12
DO-41	5,000	5.0	52	330	360 x 360 x 395	25,000	13
DO-41G	5,000	5.0	52	360	360 x 360 x 395	25,000	13
TO-252	800	16.0	16	330	350 x 337 x 44	6,400	15
MDI	3,000	8.0	12	330	375 x360 x 390	48,000	14.4
MELF/DL-41	5,000	4.0	-	330	350 x 350 x 300	100,000	14
MICRO-MELF	2,500	4.0	-	178	385 x 380 x 260	200,000	13.5
MINI-MELF	10,000 / 2,500	4.0	-	330 / 178	360 x 360 x 395 / 385 x 380 x 260	200,000 / 120,000	14.0 / 13.5
P-600	800	10.0	52	330	340 x 340 x 410	4,000	11
QFN 1.6 x 1.6	4,000	4.0	8	178	390 x 240 x 420	200,000	7.8
R-1	5,000	5.0	52	330	340 x 340 x 410	25,000	6.3
SDIP	1,500	12.0	16	330	375 x360 x 390	21,000	16.3
SMA	7,500 / 1,800	4.0	12	330 / 178	375 x360 x 390 / 390 x 240 x 420	120,000 / 72,000	17.5 / 10
SMB	3,000 / 500	4.0	12	330 / 178	375 x360 x 390 / 390 x 240 x 420	48,000 / 20,000	13.6 / 7.5
SMC	3,000 / 500	12.0	16	330 / 178	375 x360 x 390 / 390 x 240 x 420	42,000 / 15,000	6.2 / 7.3
SOD-123	10,000 / 3,000	4.0	8	330 / 178	375 x 360 x 213 / 390 x 240 x 420	120,000 / 150,000	6.4
SOD-123FL	10,000 / 3,000	4.0	8	330 / 178	375 x 360 x 213 / 390 x 240 x 420	120,000 / 150,000	6.4
SOD-323	12,000 / 5,000	4.0	8	330 / 178	375 x 360 x 213 / 390 x 240 x 420	144,000 / 250,000	10
SOT-23	10,000 / 3,000	4.0	8	330 / 178	375 x 360 x 213 / 390 x 240 x 420	144,000 / 150,000	6.4
SOT-323	10,000 / 3,000	4.0	8	330 / 178	375 x 360 x 213 / 390 x 240 x 420	144,000 / 150,000	6.4
SOT-363	10,000 / 3,000	4.0	8	330 / 178	735 x 365 x 292 / 390 x 240 x 420	300,000 / 150,000	15.66 / 7.0
SOT-353	10,000 / 3,000	4.0	8	330 / 178	735 x 365 x 292 / 390 x 240 x 420	300,000 / 150,000	15.66 / 7.0
TO-92	2,000	-	-	335	390 x 390 x 280	8,000	6.067
SOD-523	12,000 / 5,000	4.0	8	330 / 178	375 x 360 x 213 / 390 x 240 x 420	144,000 / 250,000	10
QFN 2.0 x 2.0	5,000 / 3,000 / 1,000	4.0	8	330 / 178 / 178	553 x 365 x 358 / 333 x 240 x 257 / 333 x 240 x 257	45,000 / 39,000 / 13,000	4.5 / 3.0 / 2.5
SOT23-6L	3,000 / 2,500 / 1,000	4.0	8	330 / 178 / 178	553 x 365 x 358 / 333 x 240 x 257 / 333 x 240 x 257	39,000 / 32,500 / 13,000	3.0 / 3.0 / 2.5
SOIC-08	3,000 / 1,500 / 1,000	4.0	8	330 / 330 / 178	553 x 365 x 358 / 553 x 365 x 358 / 333 x 240 x 257	39,000 / 13,500 / 13,000	6.5 / 5.0 / 3.5



## Ammunition Packing

PACKAGE	AMMO	COMPONENT SPACE	TAPE SPACE	BOX SIZE	CARTON SIZE	CARTON	APPROX. GROSS WEIGHT
	(pcs)	(m/m)	(m/m)	(m/m)	(m/m)	(EA)	(Kg)
<b>Ammunition Packing</b>							
A-405	5,000	5	26	255 x 50 x 150	399 x 276 x 330	60,000	16.0
A-405	5,000	5	52	255 x 75 x 150	399 x 276 x 330	40,000	16.0
DO-15	3,000	5	52	255 x 75 x 150	399 x 276 x 330	24,000	11.9
DO-201AD	1,250	10	52	255 x 75 x 150	399 x 276 x 330	10,000	14.0
DO-201AE	1,250	10	52	255 x 75 x 150	399 x 276 x 330	10,000	14.0
DO-34	5,000	5	26	248 x 80 x 48	410 x 335 x 265	150,000	15.5
DO-34	5,000	5	52	248 x 80 x 75	410 x 335 x 265	100,000	14.1
DO-35	5,000	5	26	248 x 80 x 48	410 x 335 x 265	150,000	20.0
DO-35	5,000	5	52	248 x 80 x 75	410 x 335 x 265	100,000	15.7
DO-41	5,000	5	52	255 x 75 x 150	399 x 276 x 330	40,000	19.1
DO-41G	2,500	5	26	248 x 80 x 48	410 x 335 x 265	75,000	21.5
DO-41G	2,500	5	52	248 x 80 x 75	410 x 335 x 265	50,000	19.0
P-600	400	10	52	255 x 75 x 150	399 x 276 x 330	3,200	9.0
R-1	5,000	5	26	255 x 50 x 150	399 x 276 x 330	40,000	16.0
R-1	5,000	5	52	255 x 75 x 150	399 x 276 x 330	40,000	16.0