



TABLE OF CONTENTS

1.DATA SHEET

PAGE 1

2.MARKING

PAGE 6

3.TAPING

PAGE 7

4.PACKING

PAGE 8

5.HIGH RELIABILITY TEST SPEC.

PAGE 13



1SMB3EZ6.8~1SMB3EZ51

GLASS PASSIVATED JUNCTION SILICON ZENER DIODES

VOLTAGE 6.8 to 51 Volts **POWER** 3.0 Watts

SMB / DO-214AA Unit: inch (mm)

FEATURES

- Low profile package
- Built-in strain relief
- Glass passivated junction
- Low inductance
- Typical I_D less than 1.0 μ A above 11V
- Plastic package has Underwriters Laboratory Flammability Classification 94V-O
- High temperature soldering : 260°C /10 seconds at terminals
- In compliance with EU RoHS 2002/95/EC directives

MECHANICAL DATA

- Case: JEDEC DO-214AA, Molded plastic over passivated junction
- Terminals: Solder plated, solderable per MIL-STD-750, Method 2026
- Polarity: Indicated by cathode band
- Standard packing: 12mm tape (E1A-481)
- Weight: 0.0032 ounce, 0.092 gram

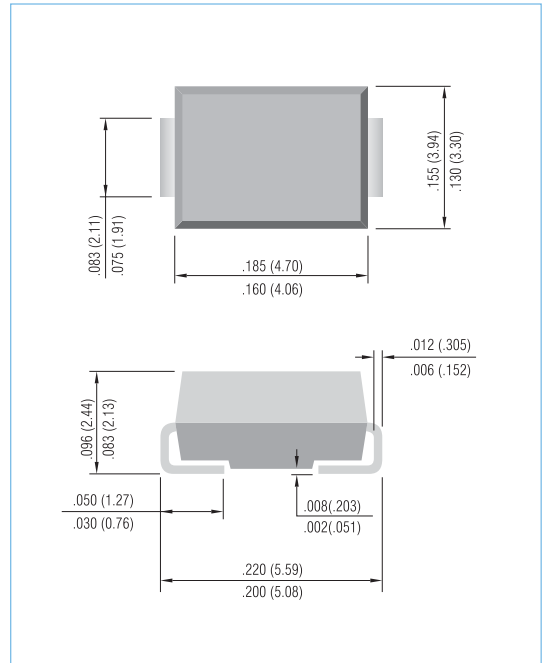

MAXIMUM RATINGS AND ELECTRICAL CHARACTERISTICS

Ratings at 25°C ambient temperature unless otherwise specified.

Parameter	Symbol	Value	Units
Pwak Pulse Power Dissipation on $T_L=50^\circ\text{C}$ (Notes A) Derate above 50°C	P_D	3.0 30.0	Watts mW/°C
Peak Forward Surge Current 8.3ms single half sine-wave superimposed on rated load (JEDEC method)	I_{FSM}	15	Amps
Operating Junction and Storage Temperature Range	T_J, T_{STG}	-55 to + 150	°C

NOTES:

A. Mounted on 5.0mm² (.013mm thick) land areas.

B. Measured on 8.3ms, and single half sine-wave or equivalent square wave, duty cycle=4 pulses per minute maximum



1SMB3EZ6.8~1SMB3EZ51

Part Number	Nominal Zener Voltage			Maximum Zener Impedance				Max Reverse Leakage Current		Marking Code
	V _Z @ I _{ZT}			Z _{ZT} @ I _{ZT}	I _{ZT}	Z _{ZK} @ I _{ZK}	I _{ZK}	I _R @ V _R		
	Nom. V	Min. V	Max. V	Ω	mA	Ω	mA	μA	V	
3.0 Watt ZENER										
1SMB3EZ6.8	6.8	6.46	7.14	2	110	700	1	5	4	6V8B
1SMB3EZ7.5	7.5	7.13	7.88	2	100	700	0.5	5	5	7V5B
1SMB3EZ8.2	8.2	7.79	8.61	2	91	700	0.5	5	6	8V2B
1SMB3EZ8.7	8.7	8.27	9.14	2	85	700	0.5	4	6.6	8V7B
1SMB3EZ9.1	9.1	8.65	9.56	3	82	700	0.5	3	7	9V1B
1SMB3EZ10	10	9.5	10.5	4	75	700	0.25	3	7.6	10B
1SMB3EZ11	11	10.45	11.55	4	68	700	0.25	1	8.4	11B
1SMB3EZ12	12	11.4	12.6	5	63	700	0.25	1	9.1	12B
1SMB3EZ13	13	12.35	13.65	5	58	700	0.25	0.5	9.9	13B
1SMB3EZ14	14	13.3	14.7	5	53	700	0.25	0.5	10.6	14B
1SMB3EZ15	15	14.25	15.75	6	50	700	0.25	0.5	11.4	15B
1SMB3EZ16	16	15.2	16.8	6	47	700	0.25	0.5	12.2	16B
1SMB3EZ17	17	16.15	17.85	6	44	750	0.25	0.5	13	17B
1SMB3EZ18	18	17.1	18.9	6	42	750	0.25	0.5	13.7	18B
1SMB3EZ19	19	18.05	19.95	7	40	750	0.25	0.5	14.4	19B
1SMB3EZ20	20	19	21	7	37	750	0.25	0.5	15.2	20B
1SMB3EZ22	22	20.9	23.1	8	34	750	0.25	0.5	16.7	22B
1SMB3EZ24	24	22.8	25.2	9	31	750	0.25	0.5	18.2	24B
1SMB3EZ25	25	23.75	26.25	10	30	750	0.25	0.5	19	25B
1SMB3EZ27	27	25.65	28.35	10	28	750	0.25	0.5	20.6	27B
1SMB3EZ28	28	26.6	29.4	12	27	750	0.25	0.5	21.3	28B
1SMB3EZ30	30	28.5	31.5	16	25	1000	0.25	0.5	22.5	30B
1SMB3EZ33	33	31.35	34.65	20	23	1000	0.25	0.5	25.1	33B
1SMB3EZ36	36	34.2	37.8	22	21	1000	0.25	0.5	27.4	36B
1SMB3EZ39	39	37.05	40.95	28	19	1000	0.25	0.5	29.7	39B
1SMB3EZ43	43	40.85	45.15	33	17	1500	0.25	0.5	32.7	43B
1SMB3EZ47	47	44.65	49.35	38	16	1500	0.25	0.5	35.8	47B
1SMB3EZ51	51	48.45	53.55	45	15	1500	0.25	0.5	38.8	51B



1SMB3EZ6.8~1SMB3EZ51

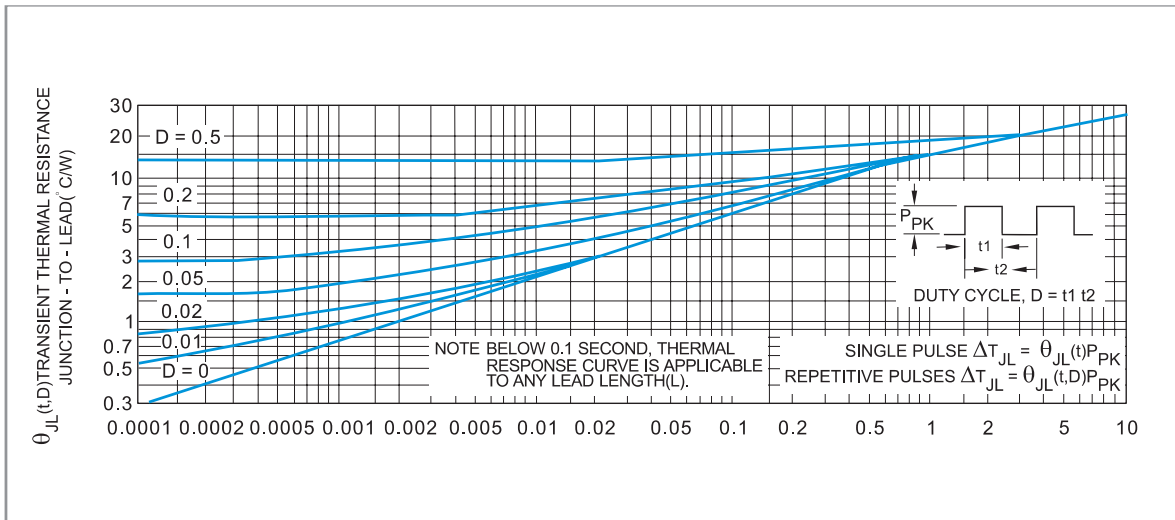

FIGURE 1. TYPICAL THERMAL RESPONSE L,

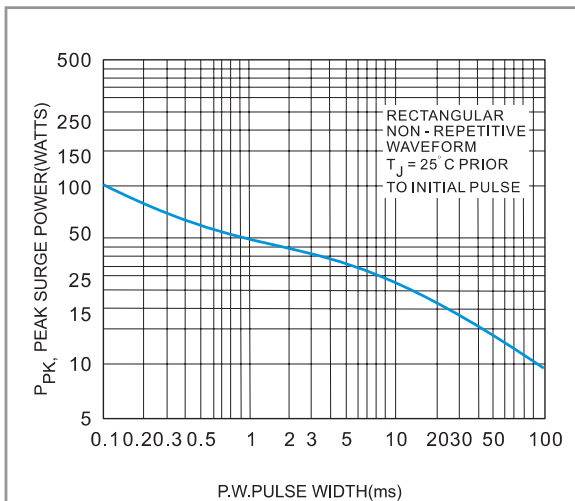

FIGURE 2. MAXIMUM SURGE POWER

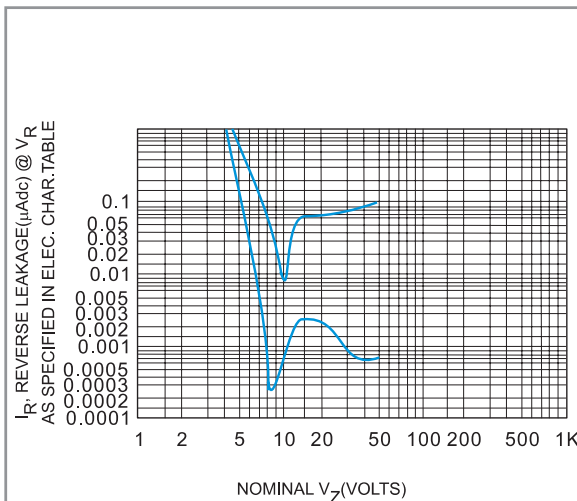

FIGURE 3. TYPICAL REVERSE LEAKAGE

APPLICATION NOTE:

Since the actual voltage available from a given zener diode is temperature dependent, it is necessary to determine junction temperature under any set of operating conditions in order to calculate its value. The following procedure is recommended:

Lead Temperature, T_L , should be determined from:

$$T_L = LA P_D + T_A$$

LA is the lead-to-ambient thermal resistance ($^{\circ}C/W$) and P_D is the power dissipation. The value for LA will vary and depends on the device mounting method. LA is generally $30-40^{\circ}C/W$ for the various clips and tie points in common use and for printed circuit board wiring.

The temperature of the lead can also be measured using a thermocouple placed on the lead as close as possible to the tie point. The thermal mass connected to the tie point is normally large enough so that it will not significantly respond to heat surges generated in the diode as a result of pulsed operation once steady-state conditions are achieved. Using the measured value of T_L , the junction temperature may be determined by:

$$T_J = T_L + T_{JL}$$

T_{JL} is the increase in junction temperature above the lead temperature and may be found from Figure 2 for a train of power pulses or from Figure 10 for dc power.

$$T_{JL} = J_L P_D$$

For worst-case design, using expected limits of I_Z , limits of P_D and the extremes of T_J (T_J) may be estimated. Changes in voltage, V_Z , can then be found from:

$$V = V_Z T_J$$

V_Z , the zener voltage temperature coefficient, is found from Figures 5 and 6.

Under high power-pulse operation, the zener voltage will vary with time and may also be affected significantly by the zener resistance. For best regulation, keep current excursions as low as possible.

Data of Figure 2 should not be used to compute surge capability. Surge limitations are given in Figure 3. They are lower than would be expected by considering only junction temperature, as current crowding effects cause temperatures to be extremely high in small spots resulting in device degradation should the limits of Figure 3 be exceeded.



1SMB3EZ6.8~1SMB3EZ51

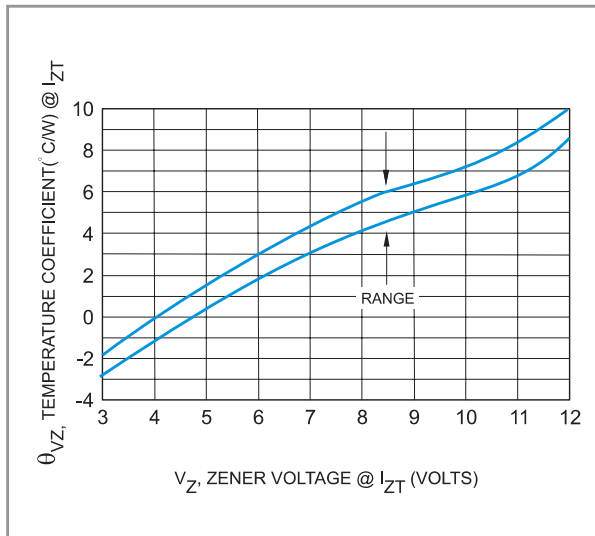

FIGURE 4. UNITS TO 12 VOLTS

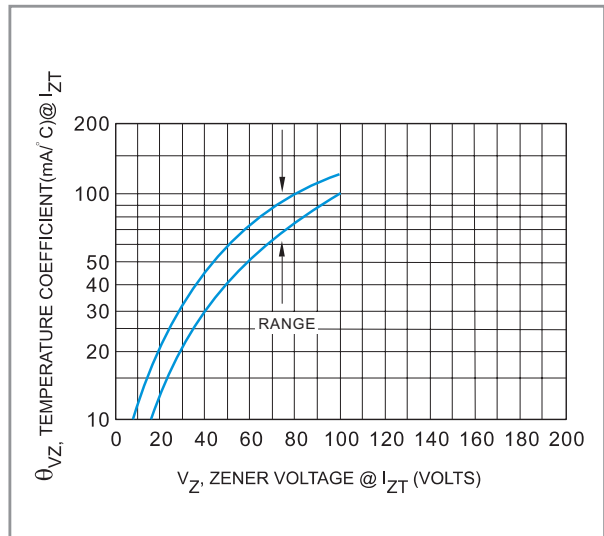

FIGURE 5. UNIT 10 TO 200 VOLTS

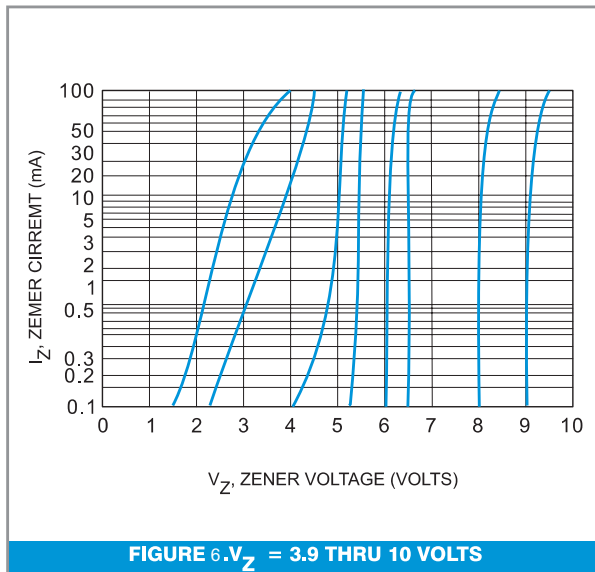

FIGURE 6. $V_Z = 3.9$ THRU 10 VOLTS

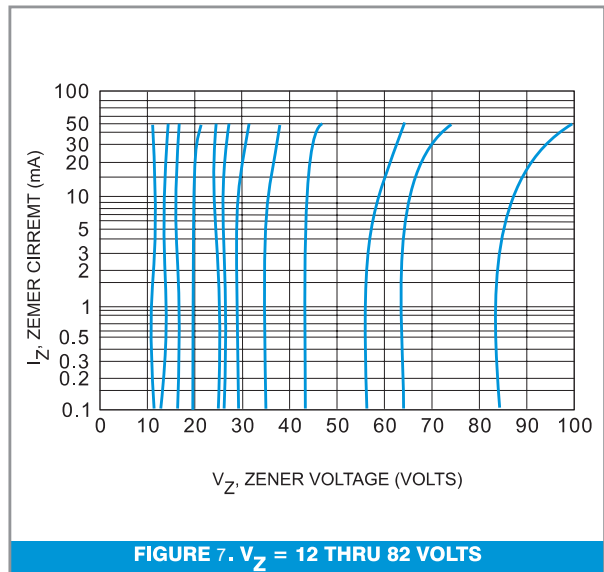

FIGURE 7. $V_Z = 12$ THRU 82 VOLTS

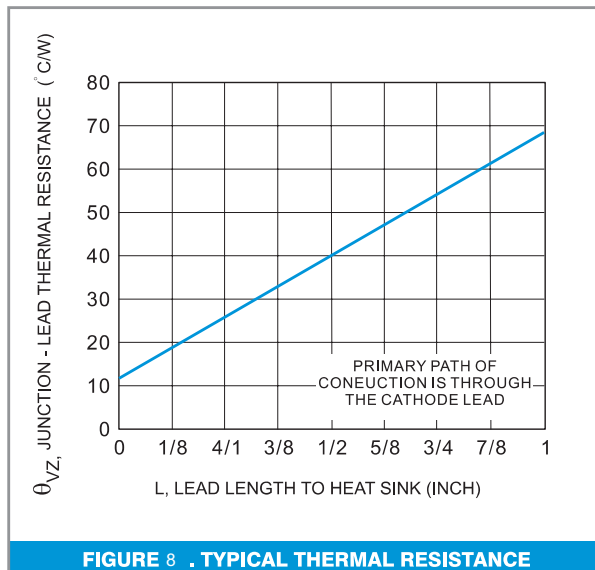
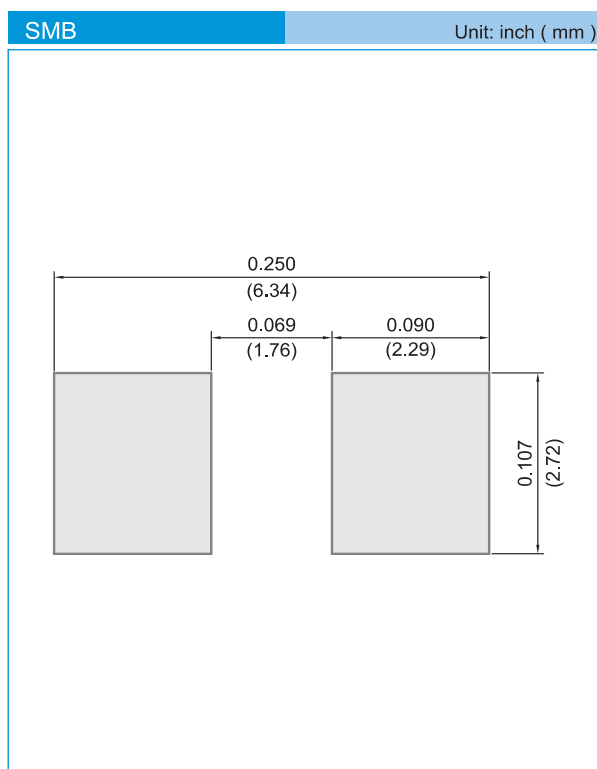

FIGURE 8 . TYPICAL THERMAL RESISTANCE



1SMB3EZ6.8~1SMB3EZ51

MOUNTING PAD LAYOUT



ORDER INFORMATION

- Packing information
 - T/R - 3K per 13" plastic Reel
 - T/R - 0.5K per 7" plastic Reel

LEGAL STATEMENT

Copyright PanJit International, Inc 2008

The information presented in this document is believed to be accurate and reliable. The specifications and information herein are subject to change without notice. Pan Jit makes no warranty, representation or guarantee regarding the suitability of its products for any particular purpose. Pan Jit products are not authorized for use in life support devices or systems. Pan Jit does not convey any license under its patent rights or rights of others.



2. MARKING

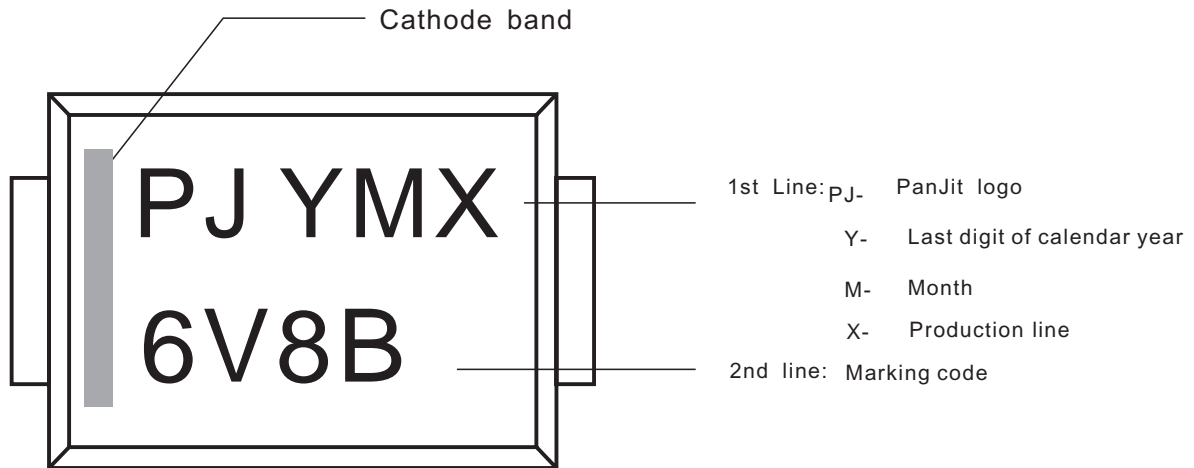



3. TAPING

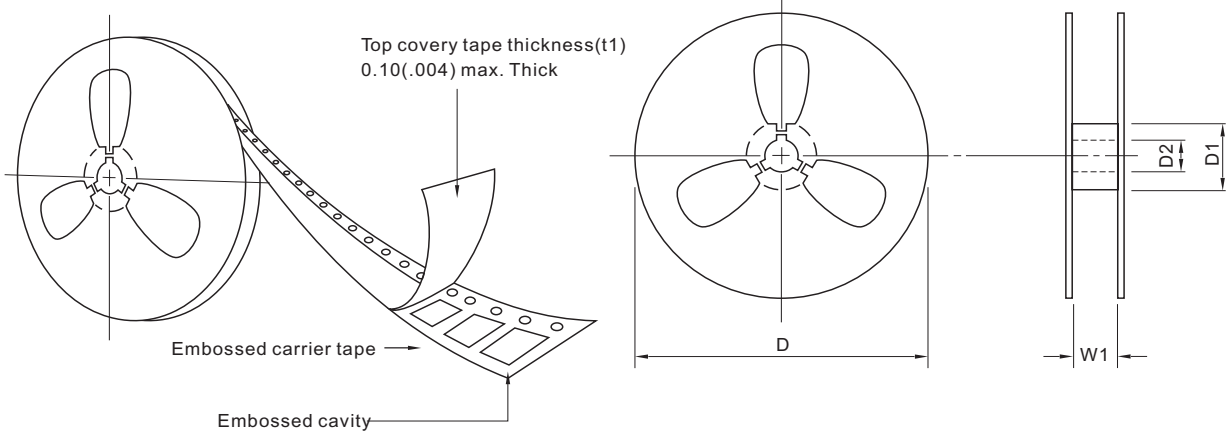
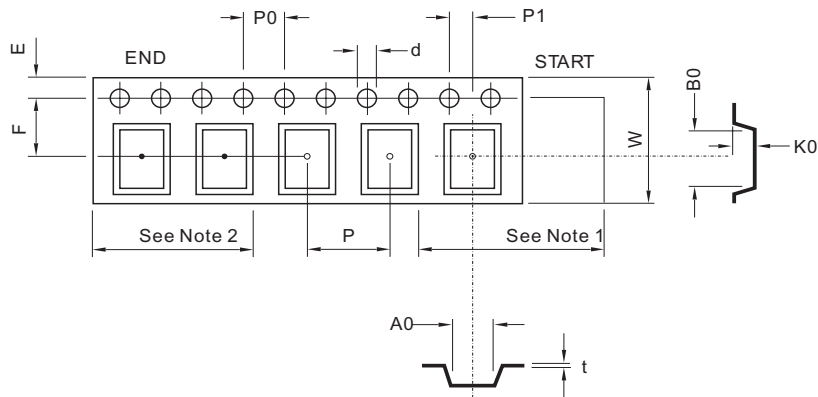

SYMBOL	mm(inch)
TYPE SIZE	12.00 (0.472)
Ao	3.81 ± 0.10 (0.15 ± 0.003)
Bo	5.74 ± 0.10 (0.22 ± 0.003)
d	1.55 ± 0.05 (0.06 ± 0.001)
D	330.0 ± 2.0 (13.0 ± 0.078)
D1	50.0 min (1.97 min)
D2	13.0 ± 0.2 (0.51 ± 0.007)
E	1.75 ± 0.10 (0.068 ± 0.003)
F	5.50 ± 0.05 (0.21 ± 0.001)
Ko	2.41 ± 0.10 (0.09 ± 0.003)
P	8.00 ± 0.10 (0.31 ± 0.003)
Po	4.00 ± 0.10 (0.15 ± 0.003)
P1	2.00 ± 0.05 (0.07 ± 0.001)
t	0.26 ± 0.10 (0.01 ± 0.003)
W	12.00 ± 3.00 (0.472 ± 0.118)
W1	14.40Maxum (0.56)

Note:

1. There shall be leader of 230 mm minimum which may consist of carrier and or cover tape follower by a minimum of 160 mm of carrier tape sealed with cover tape.
2. There shall be minimum of 160 mm of empty component pockets sealed with cover tape.
3. Devices are packed in accordance whit EIA standard EIA-481-A and specifications given above.



4. PACKING

REEL PACKING

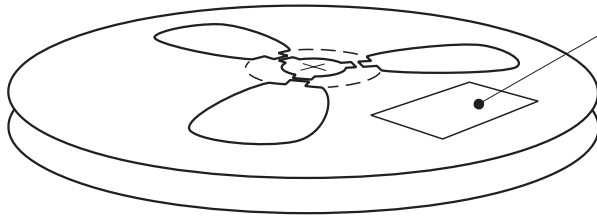

Quantity per Reel: 3,000 pcs

LABEL TYPE

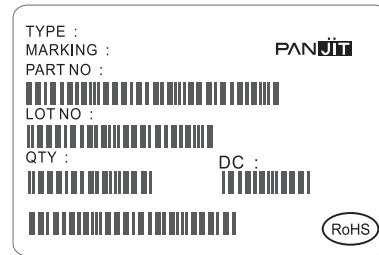

CARTON

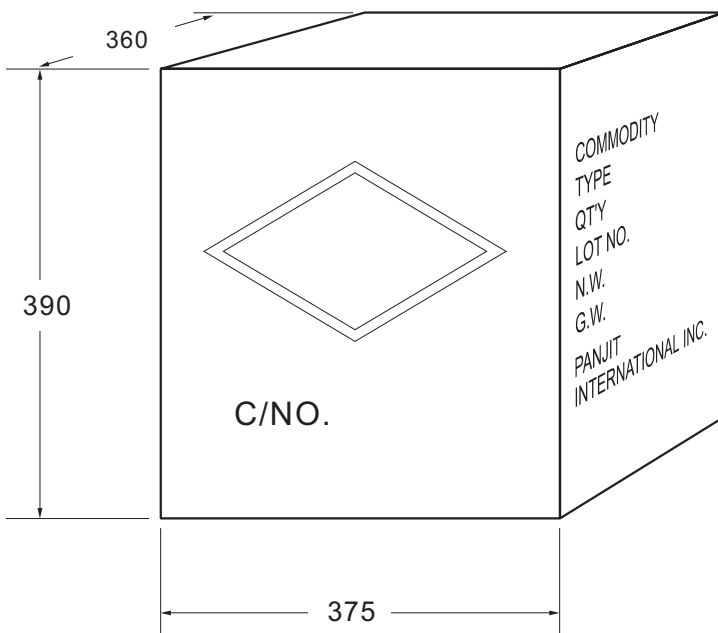

Box Dimensions : mm
Quantity per Box: 48,000pcs

SHIPPING MARK

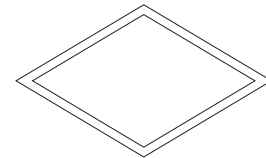

C/NO.
PRODUCT COUNTRY

SIDE MARK

COMMODITY:
TYPE:
Q'TY:
LOT NO.
N.W.
G.W.
PANJIT
INTERNATIONAL INC.



Bulk Packing

PACKAGE	INNER SIZE	BOX	CARTON SIZE	CARTON	APPROX. GROSS WEIGHT
	(m/m)	(EA)	(m/m)	(EA)	(Kg)
Bulk Packing					
A-405	198 x 84 x 20	1,000	459 x 214 x 256	50,000	12.7
AG / RB-10 (WOB)	258 x 190 x 77	1,000	395 x 270 x 400	10,000	15
AM	258 x 190 x 77	1,000	395 x 270 x 400	10,000	15
CM / KBPC	193 x 193 x 46	50	405 x 210 x 265	500	17
CMW / KBPC-W	193 x 193 x 46	50	405 x 210 x 265	500	17
KBPC-P /CP	193 x 193 x 46	50	405 x 210 x 265	500	9.5
KBPC-PW /CPW	193 x 193 x 46	50	405 x 210 x 265	500	9.5
CP-3 / 6 (K-3 / K-6)	219 x 115 x 90	200	600 x 235 x 198	2,000	7.3/8.8
CP-8 / 10 (K-8)	219 x 115 x 90	200	600 x 235 x 198	2,000	13.8
DIP	-	-	459 x 214 x 256	12,000	6.5
DO-15	200 x 85 x 25	1,000	459 x 214 x 256	40,000	20.7
DO-201AD	200 x 85 x 40	500	459 x 214 x 256	12,500	16
DO-201AE	200 x 85 x 40	500	459 x 214 x 256	12,500	16
DO-34	240 x 100 x 90	2,000	406 x 335 x 257	120,000	14.5
DO-35	240 x 100 x 90	2,000	406 x 335 x 257	120,000	17.1
DO-41	198 x 84 x 20	1,000	459 x 214 x 265	50,000	19.3
DO-41G	240 x 100 x 90	1,000	406 x 335 x 257	60,000	18.5
FL	230 x 230 x 50	500	495 x 245 x 180	3,000	18.4
GBJ (TUBE)	556 x 150 x 100	800	578 x 340 x 235	3,200	25.5
GBJ (BOX)	350 x 337 x 44	600	375 x 360 x 213	2,400	14.3
GBL	350 x 337 x 44	960	375 x 360 x 213	3,840	13.1
GBP	350 x 337 x 44	1,120	375 x 360 x 213	4,480	10.6
GBPC	193 x 193 x 46	50	405 x 210 x 265	500	17
GBPCW	193 x 193 x 46	50	405 x 210 x 265	500	17
GBU (TUBE)	488 x 150 x 100	800	510 x 310 x 235	3,200	22.6
GBU (BOX)	350 x 337 x 44	800	375 x 360 x 213	3,200	15.2
KBJ	220 x 176 x 45	200	375 x 230 x 260	2,000	15
KBPF	242 x 208 x 35	500	426 x 252 x 365	10,000	19.2
KBU	276 x 158 x 59	200	493 x 287 x 320	3,000	24
P-600	208 x 90 x 83	500	459 x 214 x 256	5,000	11.3
R-1	198 x 84 x 20	1,000	459 x 214 x 256	50,000	12.7
TO-220	540 x 145 x 85	2,000	555 x 306 x 200	8,000	20.5
ITO-220	540 x 145 x 85	2,000	555 x 306 x 200	8,000	22.9
TO-251AB	555 x 145 x 85	8,400	555 x 306 x 200	33,600	22
TO-3P / TO-247AD	-	-	536 x 243 x 100	1,500	13.9
TO-3PS / TO-247S	-	-	511 x 243 x 107	1,500	12.2



Reel Packing

PACKAGE	REEL SIZE	REEL	COMPONENT SPACE	TAPE SPACE	REEL DIA	CARTON SIZE	CARTON	APPROX. GROSS WEIGHT
	(inch)	(pcs)	(m/m)	(m/m)	(m/m)	(m/m)	(EA)	(Kg)
Reel Packing								
R-1	-	5,000	5.0	52	330	340 x 340 x 410	25,000	7.8
A-405	-	5,000	5.0	52	330	340 x 340 x 410	25,000	11
DO-15	-	4,000	5.0	52	330	340 x 340 x 410	20,000	11.4
DO-201AD	-	1,250	10.0	52	330	340 x 340 x 410	6,250	9.2
DO-201AE	-	1,250	10.0	52	330	340 x 340 x 410	6,250	9.2
DO-34	15	10,000	5.0	52	360	360 x 360 x 395	50,000	10.1
DO-35	15	10,000	5.0	52	360	360 x 360 x 395	50,000	11.2
DO-41	-	5,000	5.0	52	330	340 x 340 x 410	25,000	11.8
DO-41G	15	5,000	5.0	52	360	360 x 360 x 395	25,000	10.9
P-600	-	800	10.0	52	330	340 x 340 x 410	4,000	9.8
DPAK/TO-252	13	3,000	8.0	16	330	375 x 360 x 390	42,000	18.8
D2PAK/TO-263	13	800	16.0	24	330	375 x 360 x 390	6,400	14.4
MDI	13	3,000	8.0	12	330	375 x 360 x 390	48,000	14.7
SDIP	13	1,500	12.0	16	330	375 x 360 x 390	21,000	14.3
QUADRO-MELF	13	10,000	4.0	-	330	360 x 360 x 395	200,000	14.9
QUADRO-MELF	7	2,500	4.0	-	178	385 x 380 x 260	200,000	13.3
MELF/DL-41	13	5,000	4.0	-	330	360 x 360 x 395	100,000	23.5
MELF/DL-41	7	1,500	4.0	-	178	385 x 380 x 260	84,000	18.3
MICRO-MELF	13	10,000	4.0	-	330	360 x 360 x 395	200,000	11.5
MICRO-MELF	7	2,500	4.0	-	178	385 x 380 x 260	200,000	9.3
MINI-MELF	13	10,000	4.0	-	330	360 x 360 x 395	200,000	14.6
MINI-MELF	7	2500	4.0	-	178	385 x 380 x 260	200,000	12.7
SMA	13	7,500	4.0	12	330	375 x 360 x 390	120,000	17.3
SMA	7	1,800	4.0	12	178	390 x 240 x 420	72,000	10
SMB	13	3,000	8.0	12	330	375 x 360 x 390	48,000	13.2
SMB	7	500	8.0	12	178	390 x 240 x 420	20,000	6.5
SMC	13	3,000	8.0	16	330	375 x 360 x 390	42,000	18
SMC	7	500	8.0	16	178	390 x 240 x 420	15,000	8.3
SOD-123	13	10,000	4.0	8	330	375 x 360 x 213	120,000	6.5
SOD-123	7	3,000	4.0	8	178	390 x 270 x 400	240,000	9.9
SOD-123FL	13	10,000	4.0	8	330	375 x 360 x 213	120,000	7.2
SOD-123FL	7	3,000	4.0	8	178	390 x 270 x 400	240,000	10.6



Reel Packing

PACKAGE	REEL SIZE	REEL	COMPONENT SPACE	TAPE SPACE	REEL DIA	CARTON SIZE	CARTON	APPROX. GROSS WEIGHT
	(inch)	(pcs)	(m/m)	(m/m)	(m/m)	(m/m)	(EA)	(Kg)
Reel Packing								
SOD-323	13	12,000	4.0	8	330	375 x 360 x 213	144,000	5.9
SOD-323	7	5,000	4.0	8	178	390 x 270 x 400	400,000	9.4
SOD-523	13	12,000	4.0	8	330	375 x 360 x 213	144,000	5.4
SOD-523	7	5,000	4.0	8	178	390 x 270 x 400	400,000	9.1
SOD-723	7	8,000	2.0	8	178	390 x 270 x 400	640,000	8.5
SOD-923	7	8,000	2.0	8	178	390 x 270 x 400	640,000	7.7
SOT-23	13	12,000	4.0	8	330	375 x 360 x 213	144,000	7
SOT-23	7	3,000	4.0	8	178	390 x 270 x 400	240,000	8.3
SOT-323	13	12,000	4.0	8	330	375 x 360 x 213	144,000	6.1
SOT-323	7	3,000	4.0	8	178	390 x 270 x 400	240,000	7.9
SOT-363	13	10,000	4.0	8	330	375 x 360 x 213	120,000	7.1
SOT-363	7	3,000	4.0	8	178	390 x 270 x 400	240,000	10.2
SOT-23 (ESD)	7	3,000	4.0	8	178	455 x 270 x 440	240,000	9.5
SOT-323 (ESD)	7	3,000	4.0	8	178	455 x 270 x 440	240,000	9.1
SOT-363 (ESD)	7	3,000	4.0	8	178	455 x 270 x 440	240,000	10
SOT-353	13	10,000	4.0	8	330	375 x 360 x 213	120,000	7.2
SOT-353	7	3,000	4.0	8	178	390 x 270 x 400	240,000	10
SOT-553	13	10,000	4.0	8	330	375 x 360 x 213	120,000	5.2
SOT-553	7	4,000	4.0	8	178	390 x 270 x 400	320,000	9.4
SOT-563	13	10,000	4.0	8	330	375 x 360 x 213	120,000	5.2
SOT-563	7	4,000	4.0	8	178	390 x 270 x 400	320,000	9.4
SOT23-5L	13	10,000	4.0	8	330	375 x 360 x 213	120,000	7.9
SOT23-5L	7	3,000	4.0	8	178	390 x 270 x 400	240,000	14.5
SOT23-6L	13	10,000	4.0	8	330	375 x 360 x 213	120,000	7.9
SOT23-6L	7	3,000	4.0	8	178	390 x 270 x 400	240,000	14.5
SOT-143	13	10,000	4.0	8	330	375 x 360 x 213	120,000	7
SOT-143	7	3,000	4.0	8	178	390 x 270 x 400	240,000	12.8
SOIC-08	13	3,000	8.0	12	330	375 x 360 x 213	48,000	14.2
QFN 1.2 x 1.5	7	3,000	4.0	8	178	390 x 270 x 400	240,000	7.1
QFN 1.6 x 1.6	7	4,000	4.0	8	178	390 x 240 x 420	200,000	7.8
QFN 2.0 x 2.0	7	3,000	4.0	8	178	390 x 270 x 400	240,000	7.1



Ammunition Packing

PACKAGE	AMMO	COMPONENT SPACE	TAPE SPACE	BOX SIZE	CARTON	CARTON	APPROX. GROSS WEIGHT
	(PCS)	(m/m)	(m/m)	(m/m)	(m/m)	(E/A)	(Kg)
Ammunition Packing							
A-405	5,000	5	26	255 x 47 x 150	339 x 276 x 330	60,000	12.4
A-405	5,000	5	52	255 x 75 x 150	339 x 276 x 330	40,000	16
DO-15	3,000	5	52	255 x 75 x 150	339 x 276 x 330	24,000	13.3
DO-201AD	1,250	10	52	255 x 47 x 122	339 x 276 x 330	10,000	13.4
DO-201AE	1,250	10	52	255 x 47 x 122	339 x 276 x 330	10,000	13.4
DO-34	5,000	5	26	248 x 80 x 48	406 x 335 x 257	150,000	14.6
DO-34	5,000	5	52	248 x 80 x 75	406 x 335 x 257	100,000	12.7
DO-35	5,000	5	26	248 x 80 x 48	406 x 335 x 257	150,000	16.7
DO-35	5,000	5	52	248 x 80 x 75	406 x 335 x 257	100,000	15.2
DO-41	5,000	5	52	255 x 75 x 150	339 x 276 x 330	40,000	16
DO-41G	2,500	5	26	248 x 80 x 48	406 x 335 x 257	75,000	17.1
DO-41G	2,500	5	52	248 x 80 x 75	406 x 335 x 257	50,000	15.7
P-600	400	10	52	255 x 47 x 122	339 x 276 x 330	3,200	8.1
R-1	3,000	5	26	255 x 47 x 73	310 x 268 x 170	36,000	6.3
R-1	3,000	5	52	256 x 73 x 73	310 x 268 x 170	24,000	6.4
R-1	5,000	5	52	255 x 73 x 122	339 x 276 x 274	40,000	10.3



5. HIGH RELIABILITY TESTING SPEC.

NO	TEST ITEM	TEST CONDITION	REFERENCE DOCUMENT	LOT QUALITY LEVEL	REMARK
1	TEMPERATURE CYCLING (T.C.T)	Ta = -55 + 0, -3 °C 10min Ta = + 150 +/- °C 10min FOR 20 CYCLE	MIL-STD-750D METHOD-1051.5	LTPD 10 S.s. = 22 ACCEPT FOR 0 FAILURE ONLY.	
2	HIGH TEMPERATURE STORAGE LIFE (H.T.S.L)	Ta = 150 +/- 5 °C TESTING TIME: 168 HRS 500 HRS	MIL-STD-750D METHOD-1031.2	LTPD10 S.s. = 22 ACCEPT FOR 0 FAILURE ONLY.	
3	SOLDERABILITY TEST	TEMPERATURE OF SOLDER POT = 245 +/- 5 °C TIME FOR DIPPING FLUX = 5 -10 SEC TIME FOR DIPPING IN SOLDER = 5 +/- 0.5 SEC DIPPING DEPTH = 0.05 inch max FOR ONE CYCLE	MIL-STD-750D	METHOD-2026.10 LTPD 7 S.s. = 32 ACCEPT FOR 0 FAILURE ONLY.	
4	HIGH TEMPERATURE REVERSE BIAS (H.T.R.B)	Ta = 150 +/- 5 °C VR = 80 % VR (CUSTOM SECP) TESTING TIME: 168 HRS 500 HRS	MIL-STD-750D METHOD-1038.3	LTPD10 S.s. = 22 ACCEPT FOR 0 FAILURE ONLY.	
5	CONTINUE FORWARD OPERATING LIFE (C.F.O.L)	Ta = 55 °C I = IO +/- 10 % TESTING TIME: 168 HRS 500 HRS	MIL-STD-750D METHOD-1027.3	LTPD10 S.s. = 22 ACCEPT FOR 0 FAILURE ONLY.	
6	THERMAL SHOCK (T.S.T)	HOT TANK T = 100 °C + 10 / -2 °C t = 5 min COLD TANK T = 0 °C + 2 / -10 °C t = 5 min 15 CYCLE TIME BETWEEN TRANSFERRING DO NOT EXCEED 10 SECOND.	MIL-STD-750D METHOD-1056.7	LTPD10 S.s. = 22 ACCEPT FOR 0 FAILURE ONLY.	
7	PRESSURE COOKER (P.C.T)	Ta = 121 °C P = 1.2 kg / cm ² TIME = 96 HRS	JEDEC JESD22-A102-C	LTPD10 S.s. = 22 ACCEPT FOR 0 FAILURE ONLY.	
8	INTERMITTENT FORWARD OPERATING LIFE (I.F.O.L)	I = Io x 1.0 POWER ON : 30 SEC POWER OFF : 50 SEC TESTING TIME: 2000 CYCLES	MIL-STD-750D METHOD 1036.3	LTPD10 S.s. = 22 ACCEPT FOR 0 FAILURE ONLY.	
9	FORWARD SURGE CURRENT (I.F.S.M)	SQ WAVE OR SINE WAVE IFSM=DATE SHEET SPEC. TIME = 8.3 Msec T = 1 CYCLE	MIL-STD-750D METHOD 4066.3	LTPD10 S.s. = 22 ACCEPT FOR 0 FAILURE ONLY.	
10	HUMIDITY	Ta = 85 °C RH = 85 % TESTING TIME: 168 HRS 500 HRS	MIL-STD-750D METHOD 1021.1	LTPD10 S.s. = 22 ACCEPT FOR 0 FAILURE ONLY.	
11	SOLDERABILITY RESISTANCE	TEMPERATURE OF SOLDER POT = 260 +/- 5 °C TIME FOR DIPPING IN SOLDER = 10 + 2 / -0 SEC DIPPING DEPTH = 1.57 +/- 0.79 mm BELOW BODY FOR ONE CYCLE	MIL-STD-750D METHOD 2031.1	LTPD10 S.s. = 22 ACCEPT FOR 0 FAILURE ONLY.	

SCHOTTKY PRODUCT TESTING TEMPERATURE 100 °C +/- 5°C MAX(NORMAL)