



PJP6000

60V N-Channel Enhancement Mode MOSFET

FEATURES

- $R_{DS(ON)}$, V_{GS} @ 10V, I_{DS} @ 30A=14m Ω
- Advanced Trench Process Technology
- High Density Cell Design For Ultra Low On-Resistance
- Specially Designed for Converters and Power Motor Controls
- Fully Characterized Avalanche Voltage and Current
- In compliance with EU RoHS 2002/95/EC directives

MECHANICAL DATA

- Case: TO-220AB Molded Plastic
- Terminals : Solderable per MIL-STD-750, Method 2026
- Marking : P6000

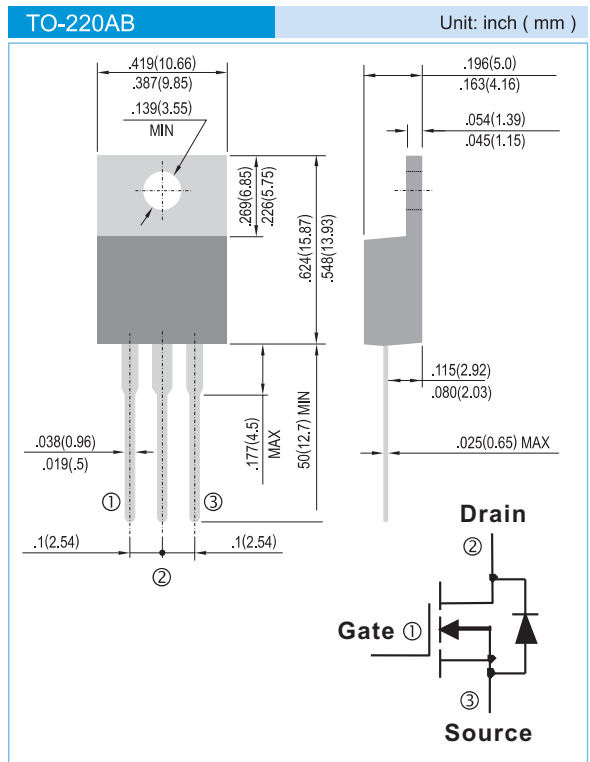

Maximum RATINGS and Thermal Characteristics ($T_A=25^\circ\text{C}$ unless otherwise noted)

PARAMETER	Symbol	Limit	Units
Drain-Source Voltage	V_{DS}	60	V
Gate-Source Voltage	V_{GS}	± 20	V
Continuous Drain Current	I_D	60	A
Pulsed Drain Current ¹⁾	I_{DM}	210	A
Maximum Power Dissipation	P_D	90 53.5	W
Operating Junction and Storage Temperature Range	T_J, T_{STG}	-55 to +150	$^\circ\text{C}$
Avalanche Energy with Single Pulse $I_{AS}=37\text{A}, V_{DD}=30\text{V}, L=0.3\text{mH}$	E_{AS}	410	mJ
Junction-to-Case Thermal Resistance	$R_{\theta JC}$	1.4	$^\circ\text{C/W}$
Junction-to Ambient Thermal Resistance(PCB mounted) ²	$R_{\theta JA}$	62	$^\circ\text{C/W}$

Note: 1. Maximum DC current limited by the package

PAN JIT RESERVES THE RIGHT TO IMPROVE PRODUCT DESIGN, FUNCTIONS AND RELIABILITY WITHOUT NOTICE



PJP6000

ELECTRICAL CHARACTERISTICS (T_A=25°C unless otherwise noted)

Parameter	Symbol	Test Condition	Min.	Typ.	Max.	Units
Static						
Drain-Source Breakdown Voltage	BV _{DSS}	V _{GS} =0V, I _D =250μA	60	-	-	V
Gate Threshold Voltage	V _{GS(th)}	V _{DS} =V _{GS} , I _D =250μA	1	-	3	V
Drain-Source On-State Resistance	R _{DS(on)}	V _{GS} =10V, I _D =30A	-	12	14	mΩ
		V _{GS} =10V, I _D =30A, T _C =125°C	-	-	26	
Zero Gate Voltage Drain Current	I _{DSS}	V _{DS} =60V, V _{GS} =0V	-	-	1	μA
		V _{DS} =60V, V _{GS} =0V, T _C =125°C	-	-	10	
Gate Body Leakage	I _{GSS}	V _{GS} =±20V, V _{DS} =0V	-	-	±100	nA
Forward Transconductance	g _{fs}	V _{DS} >I _{D(ON)} XR _{DS(ON)max} , I _D =15A	25	-	-	S
Dynamic						
Total Gate Charge	Q _g	V _{DS} =30V, I _D =30A V _{GS} =10V	-	40	-	nC
Gate-Source Charge	Q _{gs}		-	3.8	-	
Gate-Drain Charge	Q _{gd}		-	12	-	
Turn-On Delay Time	t _{d(on)}	V _{DD} =30V, R _L =15Ω I _D =2A, V _{GEN} =10V R _G =2.5Ω	-	14.6	20	ns
Turn-On Rise Time	t _r		-	14.2	18	
Turn-Off Delay Time	t _{d(off)}		-	40	60	
Turn-Off Fall Time	t _f		-	7.3	9.5	
Input Capacitance	C _{iss}	V _{DS} =25V, V _{GS} =0V f=1.0MHz	-	1480	-	pF
Output Capacitance	C _{oss}		-	190	-	
Reverse Transfer Capacitance	C _{rss}		-	135	-	
Source-Drain Diode						
Max. Diode Forward Current	I _s	-	-	-	60	A
Diode Forward Voltage	V _{SD}	I _s =30A, V _{GS} =0V	-	0.94	1.2	V

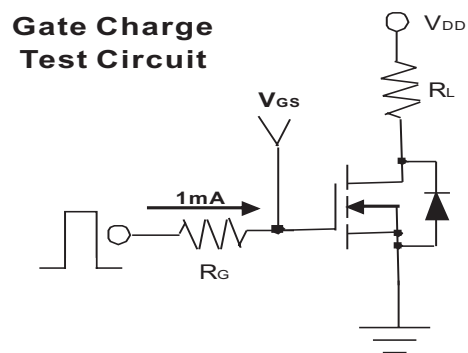
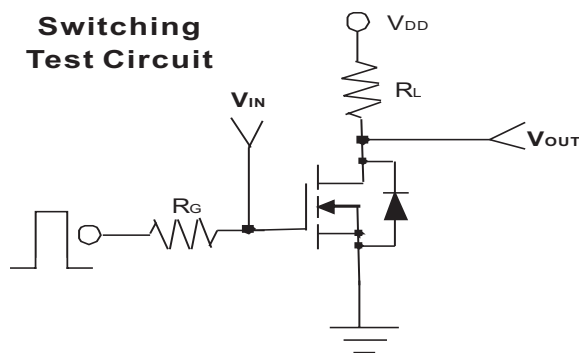



PJP6000

Typical Characteristics Curves ($T_J=25^\circ\text{C}$, unless otherwise noted)

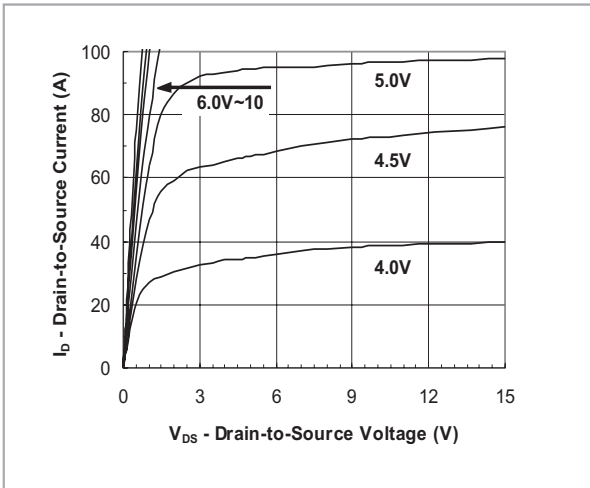

FIG.1- Output Characteristic

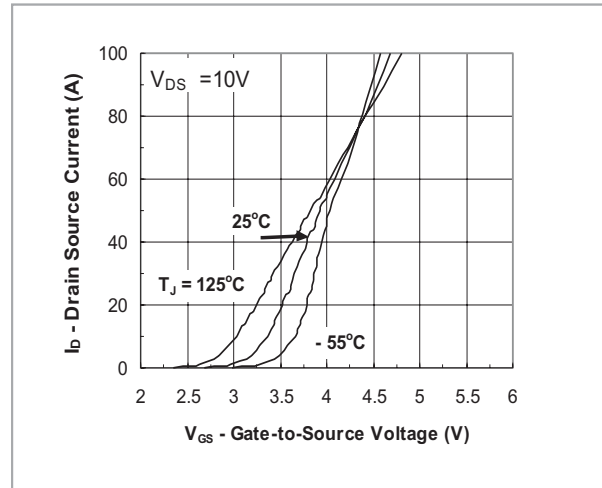

FIG.2- Transfer Characteristic

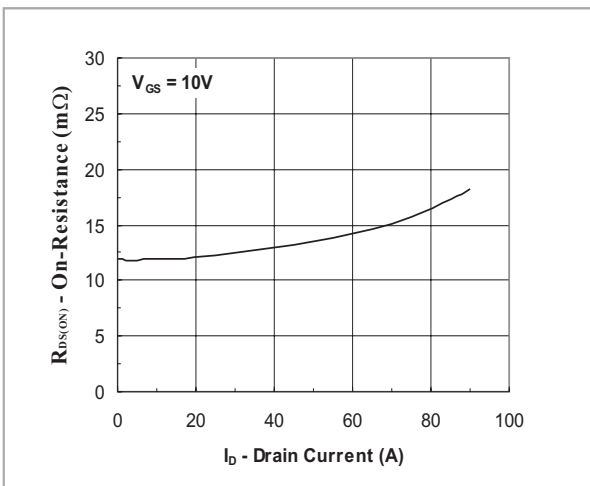

FIG.3- On Resistance vs Drain Current

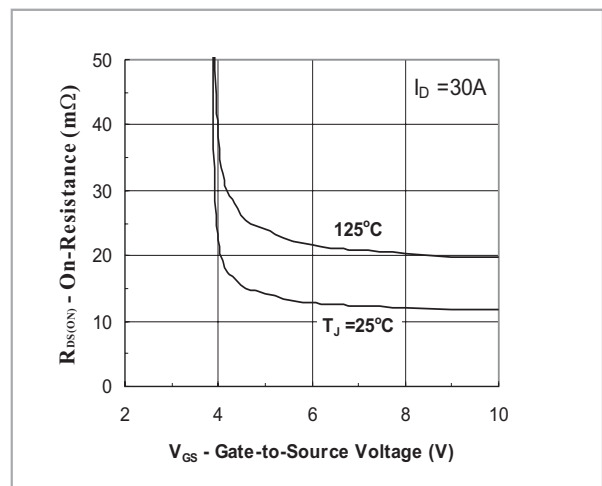

FIG.4- On Resistance vs Gate to Source Voltage

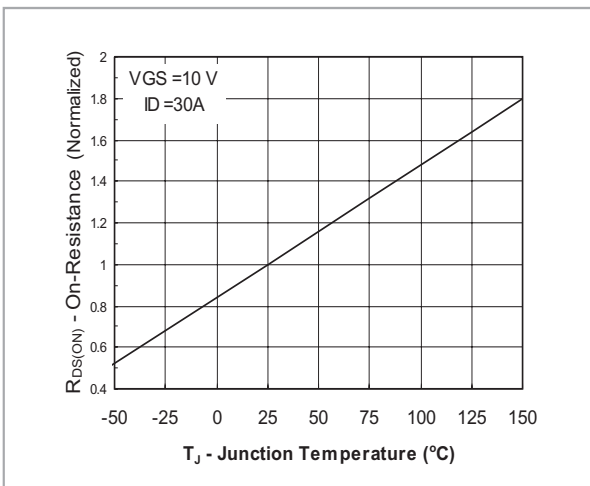

FIG.5- On Resistance vs Junction Temperature

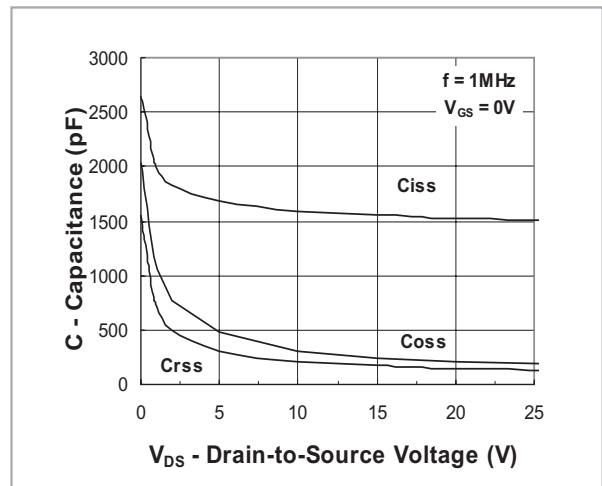

FIG.6 - Capacitance



PJP6000

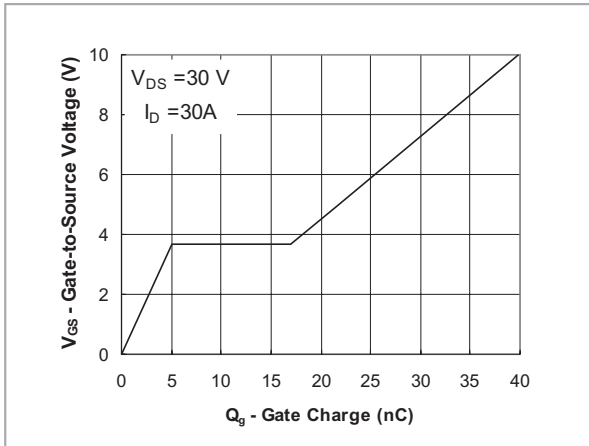

Fig. 7 - Gate Charge

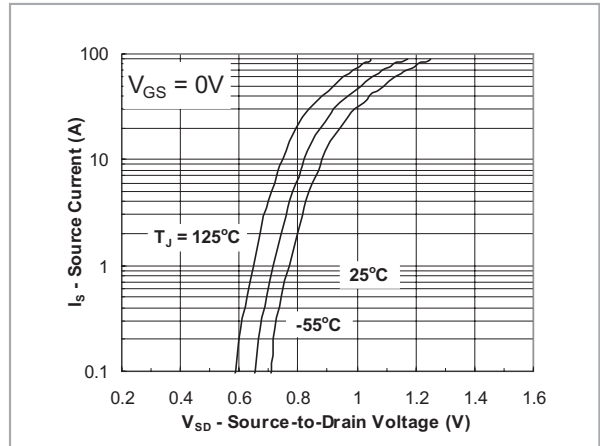

Fig. 10 - Source-Drain Diode Forward Voltage

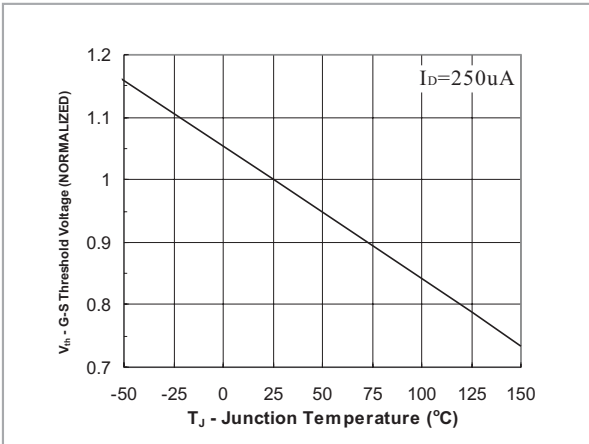

Fig. 8 - Threshold Voltage vs Junction Temperature

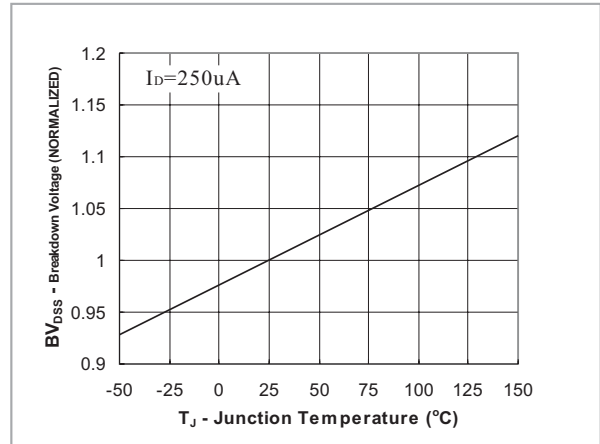

Fig. 9 - Breakdown Voltage vs Junction Temperature

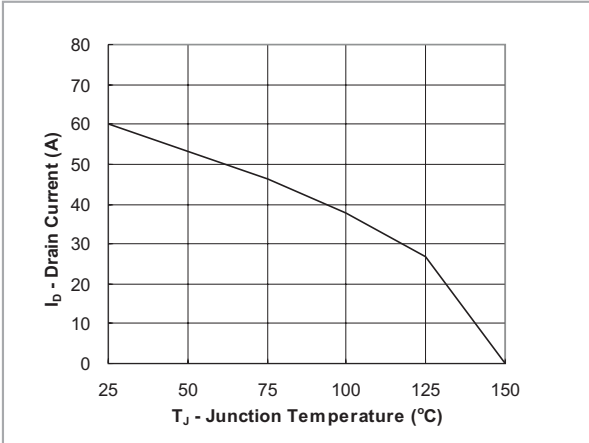

Fig. 11 - Maximum Drain Current vs Junction Temperature

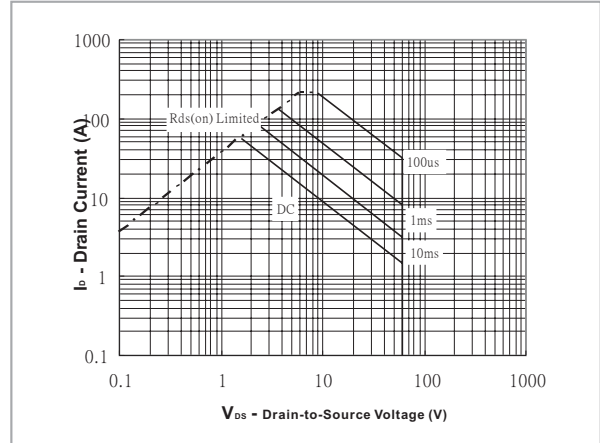
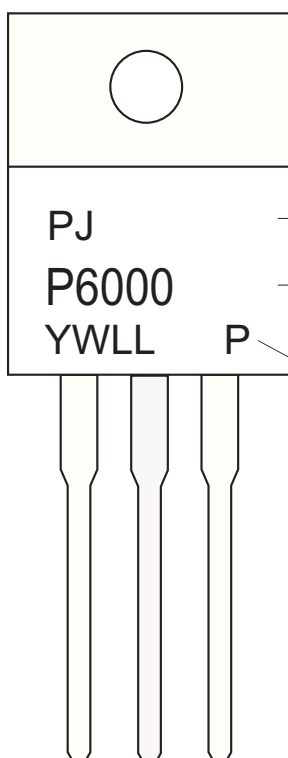

Fig. 12 - Safe Operation Area



2. MARKING



1st line: PanJit logo

2nd line: Marking code

3rdline:

Y- Last digit of calendar year

WW- Weekly

LL-The latest two digits of wafer lot #

P-FIXED



3. PACKING

INNER BOX

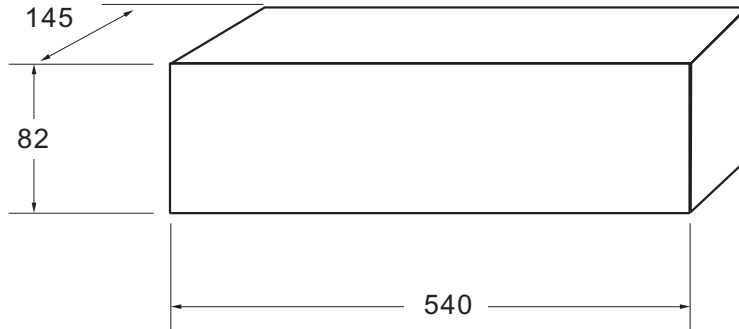

Box Dimensions : mm
Quantity per Carton: 2,000 pcs

CARTON

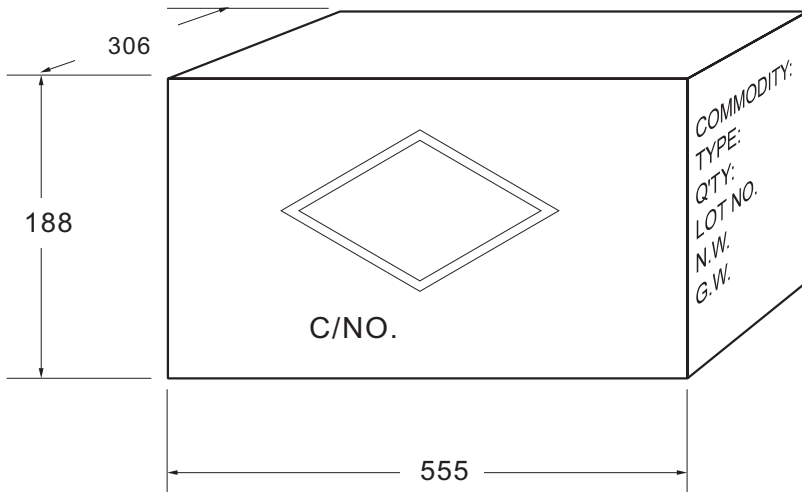

Box Dimensions : mm
Quantity per Box: 8,000 pcs

SHIPPING MARK

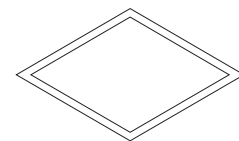

C/NO.
PRODUCT COUNTRY

SIDE MARK

COMMODITY:
TYPE:
Q'TY:
LOT NO.
N.W.
G.W.
PANJIT
INTERNATIONAL INC.



Bulk Packing

PACKAGE	INNER BOX SIZE	BOX	CARTON SIZE	CARTON	APPROX. GROSS WEIGHT
	(m/m)	(EA)	(m/m)	(EA)	(Kg)
Bulk Packing					
A-405	198 x 84 x 20	1,000	459 x 214 x 256	50,000	18.2
AG / RB-20 / WOB	258 x 190 x 77	1,000	395 x 270 x 400	10,000	17
AM	258 x 190 x 77	1,000	395 x 270 x 400	10,000	15
CM / KBPC	193 x 193 x 46	50	405 x 210 x 265	500	17
CMW / KBPC-W	193 x 193 x 46	25	405 x 210 x 265	250	8.5
KBPC-P /CP-15 / 25 / 35 / 50	193 x 193 x 46	50	405 x 210 x 265	500	12
KBPC-PW /CPW-15 / 25 / 35 / 50	193 x 193 x 46	25	405 x 210 x 265	250	6
CP-3 / 6	219 x 115 x 90	200	600 x 235 x 198	2,000	7.3/8.8
CP-8 / 10	219 x 115 x 90	200	600 x 235 x 198	2,000	13.8
DIP	-	-	495 x 214 x 256	12,000	9
DO-15	200 x 85 x 25	1,000	459 x 214 x 256	40,000	20.2
DO-201AD	200 x 85 x 40	500	495 x 214 x 256	12,500	15.8
DO-201AE	200 x 85 x 40	500	495 x 214 x 256	12,500	15.9
DO-34	96 x 80 x 42	2,000	410 x 335 x 265	120,000	14.4
DO-35	96 x 80 x 42	2,000	410 x 335 x 265	120,000	17.4
DO-41	198 x 84 x 20	1,000	459 x 214 x 265	50,000	19.4
DO-41G	96 x 80 x 42	1,000	410 x 335 x 265	60,000	18
FL	230 x 230 x 50	500	495 x 245 x 180	3,000	18.4
FI	488 x 150 x 100	1,200	510 x 340 x 235	24,000	18
GBJ (TUBE)	556 x 150 x 100	800	578 x 340 x 235	3,200	25.4
GBJ (BOX)	350 x 337 x 44	600	375 x 360 x 213	2,400	14.4
GBL	350 x 337 x 44	960	375 x 360 x 213	3,840	13.1
GBP	350 x 337 x 44	1,120	375 x 360 x 213	4,480	10.9
GBPC	193 x 193 x 46	50	405 x 210 x 265	500	17
GBPCW	193 x 193 x 46	25	405 x 210 x 265	250	8.5
GBU (TUBE)	488 x 150 x 100	800	510 x 310 x 235	3,200	23.2
GBU (BOX)	350 x 337 x 44	800	375 x 360 x 213	3,200	16.9
GL	195 x 195 x 40	80	460 x 215 x 260	800	11
GPJ	500 x 150 x 145	750	572 x 306 x 218	1,500	17
KBJ	221 x 176 x 45	200	376 x 263 x 241	2,000	15
KBPF	242 x 208 x 35	500	426 x 252 x 365	10,000	19.2
KBU	276 x 158 x 59	200	493 x 287 x 320	3,000	24
MDI	350 x 337 x 44	6,000	375 x 360 x 390	48,000	14.4
P-600	208 x 90 x 83	500	459 x 214 x 256	5,000	12.1
R-1	198 x 84 x 20	1,000	459 x 214 x 256	50,000	11.8
SDIP	-	-	495 x 214 x 256	24,000	12.4
TO-220	540 x 145 x 82	2,000	555 x 306 x 188	8,000	22
ITO-220	540 x 145 x 82	2,000	555 x 306 x 188	8,000	19.6
TO-251AB	555 x 145 x 95	8,400	572 x 306 x 218	33,600	22
TO-3P / TO-247AD	-	-	536 x 243 x 100	1,500	13
KBL	230 x 147 x 50	200	460 x 245 x 275	3,000	17.25
K3 / K6	219 x 115 x 90	200	600 x 235 x 198	2,000	7.3/8.8
K8	210 x 115 x 90	200	600 x 235 x 198	2,000	13.8



Reel Packing

PACKAGE	REEL SIZE (inch)	REEL (pcs)	COMPONENT SPACE (m/m)	TAPE SPACE (m/m)	REEL DIA (m/m)	CARTON SIZE (m/m)	CARTON (EA)	APPROX. GROSS WEIGHT (Kg)
Reel Packing								
R-1	-	5,000	5.0	52	330	340 x 340 x 410	25,000	7.9
A-405	-	5,000	5.0	52	330	340 x 340 x 410	25,000	11.3
DO-15	-	4,000	5.0	52	330	340 x 340 x 410	20,000	11
DO-201AD	-	1,250	10.0	52	330	340 x 340 x 410	6,250	9.6
DO-201AE	-	1,250	10.0	52	330	340 x 340 x 410	6,250	9.6
DO-34	15	10,000	5.0	52	360	360 x 360 x 395	50,000	9.5
DO-35	15	10,000	5.0	52	360	360 x 360 x 395	50,000	11.4
DO-41	-	5,000	5.0	52	330	340 x 340 x 410	25,000	11.8
DO-41G	15	5,000	5.0	52	360	360 x 360 x 395	25,000	11.3
P-600	-	800	10.0	52	330	340 x 340 x 410	4,000	10
DDPAK/TO-252	13	3,000	8.0	16	330	375 x 360 x 390	42,000	20.1
D2PAK/TO-263	13	800	16.0	24	330	375 x 360 x 390	6,400	14.7
MDI	13	3,000	8.0	12	330	375 x 360 x 390	48,000	14.6
SDIP	13	1,500	12.0	16	330	375 x 360 x 390	21,000	14.9
QUADRO-MELF	7	2,500	4.0	-	178	385 x 380 x 260	200,000	13.5
MELF/DL-41	13	5,000	4.0	-	330	360 x 360 x 395	200,000	23.4
MICRO-MELF	7	2,500	4.0	-	178	385 x 380 x 260	200,000	9.1
MINI-MELF	13	10,000	4.0	-	330	360 x 360 x 395	200,000	14.8
MINI-MELF	7	2500	4.0	-	178	385 x 380 x 260	120,000	13
SMA	13	7,500	4.0	12	330	375 x 360 x 390	120,000	17.5
SMA	7	1,800	4.0	12	178	390 x 240 x 420	72,000	10
SMB	13	3,000	8.0	12	330	375 x 360 x 390	48,000	13.6
SMB	7	500	8.0	12	178	390 x 240 x 420	20,000	6.5
SMC	13	3,000	8.0	16	330	375 x 360 x 390	42,000	18.4
SMC	7	500	8.0	16	178	390 x 240 x 420	15,000	8.5
SOD-123	13	10,000	4.0	8	330	375 x 360 x 213	120,000	6.4
SOD-123	7	3,000	4.0	8	178	390 x 270 x 400	240,000	9.4
SOD-123FL	13	10,000	4.0	8	330	375 x 360 x 213	120,000	6.4
SOD-123FL	7	3,000	4.0	8	178	390 x 270 x 400	240,000	9.4
SOD-323	13	12,000	4.0	8	330	375 x 360 x 213	144,000	10
SOD-323	7	5,000	4.0	8	178	390 x 270 x 400	400,000	15.2
SOD-523	13	12,000	4.0	8	330	375 x 360 x 213	144,000	10
SOD-523	7	5,000	4.0	8	178	390 x 270 x 400	400,000	15.2
SOT-23	13	12,000	4.0	8	330	375 x 360 x 213	144,000	6.4
SOT-23	7	3,000	4.0	8	178	390 x 270 x 400	240,000	9.4
SOT-323	13	12,000	4.0	8	330	375 x 360 x 213	144,000	6.4
SOT-323	7	3,000	4.0	8	178	390 x 270 x 400	240,000	9.4
SOT-363	13	10,000	4.0	8	330	375 x 360 x 213	120,000	7.1
SOT-363	7	3,000	4.0	8	178	390 x 270 x 400	240,000	10.2
SOT-353	13	10,000	4.0	8	330	375 x 360 x 213	120,000	7.2
SOT-353	7	3,000	4.0	8	178	390 x 270 x 400	240,000	10
SOT23-6L	13	10,000	4.0	8	330	375 x 360 x 213	120,000	7.9
SOT23-6L	7	3,000	4.0	8	178	390 x 270 x 400	240,000	14.5
SOT-143	13	10,000	4.0	8	330	375 x 360 x 213	120,000	7
SOT-143	7	3,000	4.0	8	178	390 x 270 x 400	240,000	12.8
QFN 1.2 x 1.5	7	3,000	4.0	8	178	390 x 270 x 400	240,000	7.1
QFN 1.6 x 1.6	7	4,000	4.0	8	178	390 x 240 x 420	200,000	7.8
QFN 2.0 x 2.0	7	3,000	4.0	8	178	390 x 270 x 400	240,000	7.1
SOIC-08	13	3,000	8.0	12	330	375 x 360 x 390	48,000	14.2



Ammunition Packing

PACKAGE	AMMO	COMPONENT SPACE	TAPE SPACE	INNER BOX SIZE	CARTON SIZE	CARTON	APPROX. GROSS WEIGHT
	(pcs)	(m/m)	(m/m)	(m/m)	(m/m)	(EA)	(Kg)
Ammunition Packing							
A-405	5,000	5	26	255 x 47 x 150	339 x 276 x 330	60,000	12.4
A-405	5,000	5	52	255 x 75 x 150	339 x 276 x 330	40,000	16
DO-15	3,000	5	52	255 x 75 x 150	339 x 276 x 330	24,000	12.9
DO-201AD	1,250	10	52	255 x 47 x 122	339 x 276 x 330	10,000	13.3
DO-201AE	1,250	10	52	255 x 47 x 122	339 x 276 x 330	10,000	13.3
DO-34	5,000	5	26	248 x 80 x 48	406 x 335 x 257	150,000	14.7
DO-34	5,000	5	52	248 x 80 x 75	406 x 335 x 257	100,000	12.4
DO-35	5,000	5	26	248 x 80 x 48	406 x 335 x 257	150,000	16.7
DO-35	5,000	5	52	248 x 80 x 75	406 x 335 x 257	100,000	15
DO-41	5,000	5	52	255 x 75 x 150	339 x 276 x 330	40,000	16.6
DO-41G	2,500	5	26	248 x 80 x 48	406 x 335 x 257	75,000	22.7
DO-41G	2,500	5	52	248 x 80 x 75	406 x 335 x 257	50,000	15.7
P-600	400	10	52	255 x 47 x 122	339 x 276 x 330	3,200	7.8
R-1	3,000	5	26	255 x 47 x 73	310 x 268 x 170	36,000	6.8
R-1	3,000	5	52	256 x 73 x 73	310 x 268 x 170	24,000	6.2
R-1	5,000	5	52	255 x 73 x 122	339 x 276 x 274	40,000	10.1



4. HIGH RELIABILITY TESTING SPEC.

NO	TEST ITEM	TEST CONDITION	REFERENCE DOCUMENT	LOT QUALITY LEVEL	REMARK
1	TEMPERATURE CYCLING (T.C.T)	Ta = -55 + 0, -3 °C 10min Ta = + 150 +/- - °C 10min FOR 20 CYCLE	MIL-STD-750D METHOD-1051.5	LTPD 10 S.s. = 22 ACCEPT FOR 0 FAILURE ONLY.	
2	HIGH TEMPERATURE STORAGE LIFE (H.T.S.L)	Ta = 150 +/- - 5 °C TESTING TIME: 168 HRS 500 HRS	MIL-STD-750D METHOD-1031.2	LTPD10 S.s. = 22 ACCEPT FOR 0 FAILURE ONLY.	
3	SOLDERABILITY TEST	TEMPERATURE OF SOLDER POT = 245 +/- - 5 °C TIME FOR DIPPING FLUX = 5 -10 SEC TIME FOR DIPPING IN SOLDER = 5 +/- - 0.5 SEC DIPPING DEPTH = 0.05 inch max FOR ONE CYCLE	MIL-STD-750D	METHOD-2026.10 LTPD 7 S.s. = 32 ACCEPT FOR 0 FAILURE ONLY.	
4	HIGH TEMPERATURE REVERSE BIAS (H.T.R.B)	Ta = 150 +/- - 5 °C VR = 80 % VR (CUSTOM SECP) TESTING TIME: 168 HRS 500 HRS	MIL-STD-750D METHOD-1038.3	LTPD10 S.s. = 22 ACCEPT FOR 0 FAILURE ONLY.	
5	CONTINUE FORWARD OPERATING LIFE (C.F.O.L)	Ta = 55 °C I = IO +/- -10 % TESTING TIME: 168 HRS 500 HRS	MIL-STD-750D METHOD-1027.3	LTPD10 S.s. = 22 ACCEPT FOR 0 FAILURE ONLY.	
6	THERMAL SHOCK (T.S.T)	HOT TANK T = 100 °C + 10 / -2 °C t = 5 min COLD TANK T = 0 °C + 2 / -10 °C t = 5 min 15 CYCLE TIME BETWEEN TRANSFERRING DO'NOT EXCEED 10 SECOND.	MIL-STD-750D METHOD-1056.7	LTPD10 S.s. = 22 ACCEPT FOR 0 FAILURE ONLY.	
7	PRESSURE COOKER (P.C.T)	Ta = 121 °C P = 1.2 kg / cm ² TIME = 96 HRS	JEDEC JESD22-A102-C	LTPD10 S.s. = 22 ACCEPT FOR 0 FAILURE ONLY.	
8	INTERMITTENT FORWARD OPERATING LIFE (I.F.O.L)	I = IO x 1.0 POWER ON : 30 SEC POWER OFF : 50 SEC TESTING TIME: 2000 CYCLES	MIL-STD-750D METHOD 1036.3	LTPD10 S.s. = 22 ACCEPT FOR 0 FAILURE ONLY.	
9	FORWARD SURGE CURRENT (I.F.S.M)	SQ WAVE OR SINE WAVE IFSM=DATE SHEET SPEC. TIME = 8.3 Msec T = 1 CYCLE	MIL-STD-750D METHOD 4066.3	LTPD10 S.s. = 22 ACCEPT FOR 0 FAILURE ONLY.	
10	HUMIDITY	Ta = 85 °C RH = 85 % TESTING TIME: 168 HRS 500 HRS	MIL-STD-750D METHOD 1021.1	LTPD10 S.s. = 22 ACCEPT FOR 0 FAILURE ONLY.	
11	SOLDERABILITY RESISTANCE	TEMPERATURE OF SOLDER POT = 260 +/- -5 °C TIME FOR DIPPING IN SOLDER = 10 + 2 / -0 SEC DIPPING DEPTH = 1.57 +/- 0.79 mm BELOW BODY FOR ONE CYCLE	MIL-STD-750D METHOD 2031.1	LTPD10 S.s. = 22 ACCEPT FOR 0 FAILURE ONLY.	

SCHOTTKY PRODUCT TESTING TEMPERATURE 100 °C +/- 5°C MAX(NORMAL)