

QUAD SCHOTTKY DATA LINE BUS TERMINATOR

This highly integrated device is designed as rail to rail overvoltage protection clamp for up to four high frequency data lines. It is ideal in portable applications where small form factors are required.

FEATURES

- Low Forward Voltage Drop for Improved Voltage Protection
- Very Fast Switching
- Ultra Small SOT-363 Package Utilizing Minimal Board Space
- Lead Free Plating, 100% Matte Tin Finish, RoHS Compliant

APPLICATIONS

- PDAs
- Portable Computers

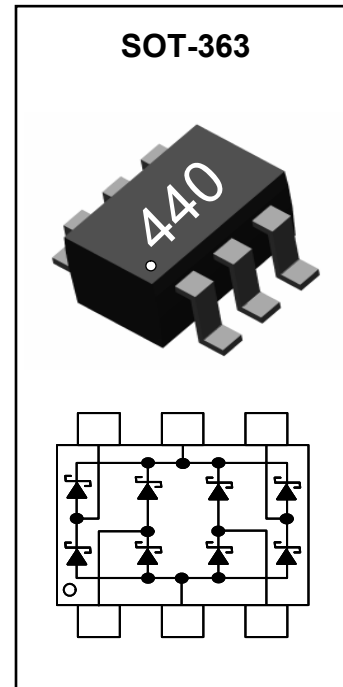

MAXIMUM RATINGS $T_A = 25^\circ\text{C}$, unless otherwise noted

Rating	Symbol	Value	Units
Marking Code		440	
Reverse Voltage	V_R	30	V
Continuous Forward Current	I_F	200	mA
Non-Repetitive Surge Current, $t=1\text{s}$	I_{FSM}	600	mA
Power Dissipation (Note 1)	P_D	200	mW
Operating Junction Temperature Range	T_J	-55 to +125	$^\circ\text{C}$
Storage Temperature Range	T_{STG}	-65 to +125	$^\circ\text{C}$

Note 1: Device mounted on FR-4 board 1.0 inch x 0.85 inch x 0.062 inch, with minimum pad layout

THERMAL CHARACTERISTICS

Characteristic	Symbol	Value	Units
Thermal Resistance, Junction to Ambient	R_{thja}	625	$^\circ\text{C/W}$

ELECTRICAL CHARACTERISTICS (Each Diode)

$T_J = 25^\circ\text{C}$, unless otherwise noted

Characteristic	Symbol	Min	Typ	Max	Units
Reverse Breakdown Voltage (Note 2)	V_{BR}	30	-	-	V
Forward Voltage (Note 2)	$I_F = 0.1\text{mA}$	-	0.225	0.280	V
	$I_F = 1.0\text{mA}$	-	0.280	0.350	
	$I_F = 10\text{mA}$	-	0.350	0.450	
	$I_F = 30\text{mA}$	-	0.390	0.550	
	$I_F = 100\text{mA}$	-	0.460	1.0	
Reverse Leakage Current (Note 2)	I_R	-	-	2.0	μA
Total Capacitance $V_R = 0\text{V}$, $f = 1.0\text{MHz}$	Data Line to Ground	-	19	-	pF
	Between Data Lines	-	12	-	
Reverse Recovery Time	t_{rr}	-	-	5.0	ns

Note 2: Short duration test pulse to minimize self heating

ELECTRICAL CHARACTERISTIC CURVES (Each Diode)

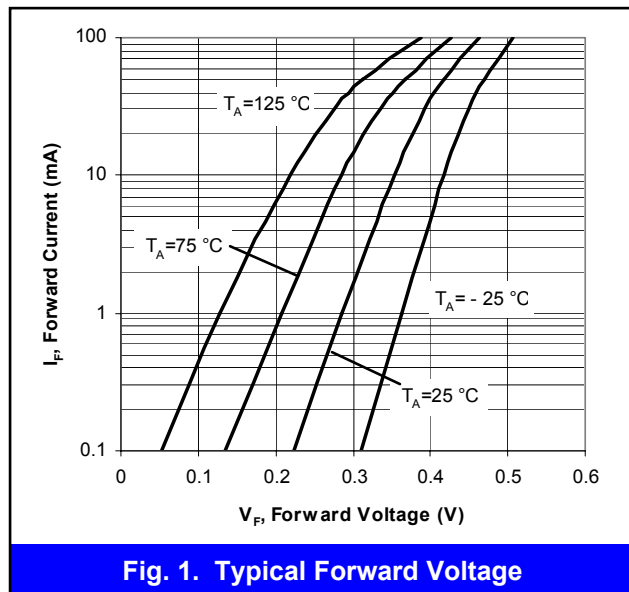

Fig. 1. Typical Forward Voltage

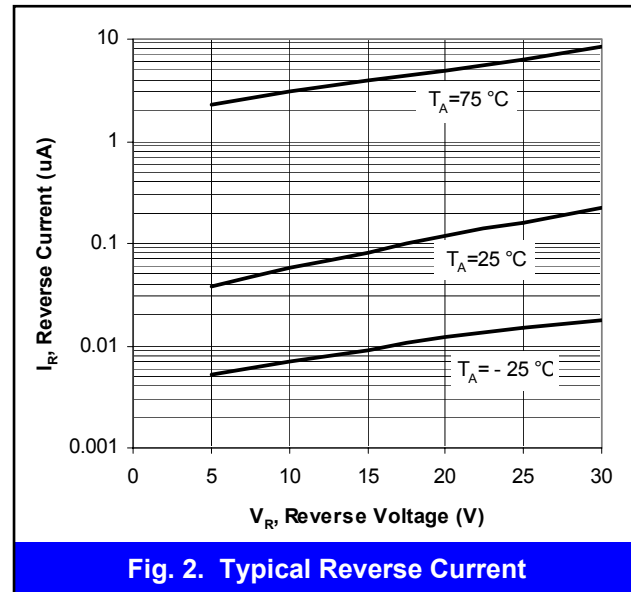
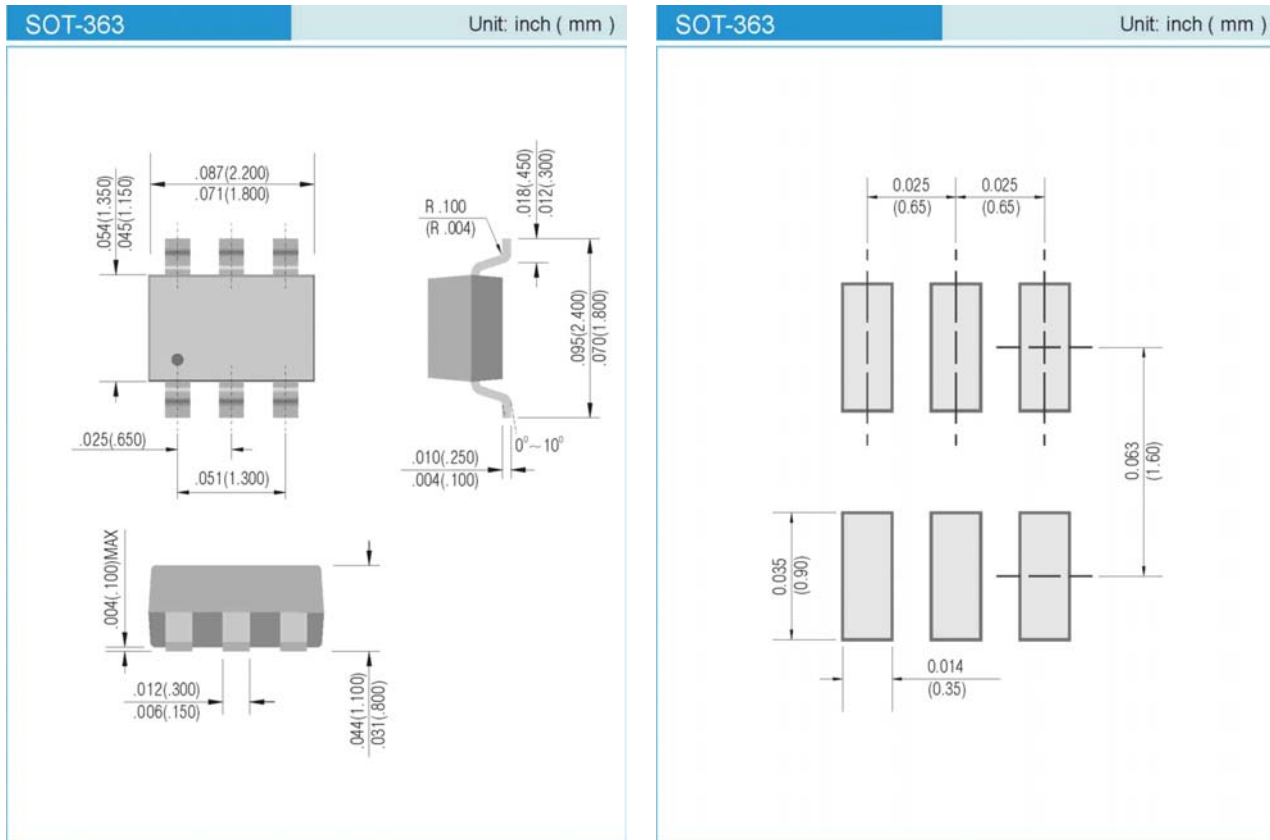

Fig. 2. Typical Reverse Current

PACKAGE LAYOUT AND SUGGESTED PAD DIMENSIONS



ORDERING INFORMATION

PJ4L40 T/R7 - 7 inch reel, 3K units per reel

PJ4L40 T/R13 - 13 inch reel, 10K units per reel

Copyright PanJit International, Inc 2008

The information presented in this document is believed to be accurate and reliable. The specifications and information herein are subject to change without notice. Pan Jit makes no warranty, representation or guarantee regarding the suitability of its products for any particular purpose. Pan Jit products are not authorized for use in life support devices or systems. Pan Jit does not convey any license under its patent rights or rights of others.

Note :

- 1.To protect data lines and the power line, connect pins 2 and 3 directly to the positive supply rail (V_{CC}).In this configuration the data lines are referenced to the supply voltage. An external TVS diode may be added between the supply rail and ground in order to prevent over-voltage on the supply rail.
- 2.In applications where no positive supply reference is available, or complete supply isolation is desired, an external TVS diode may be used as the reference.The steering diodes will begin to conduct when the voltage on the protected line exceeds the working voltage of the TVS (plus one diode drop).