



TABLE OF CONTENTS

1.DATA SHEET

PAGE 1

2.MARKING

PAGE 4

3.TAPING

PAGE 5

4.PACKING

PAGE 6

5.HIGH RELIABILITY TEST SPEC.

PAGE 11



TB1S-05~TB10S-05

MICRO SURFACE MOUNT GLASS PASSIVATED SINGLE-PHASE BRIDGE RECTIFIER

VOLTAGE 100~1000 Volts **CURRENT** 0.5 Amperes

TDI(MICRO DIP)

Unit : Inch(mm)

FEATURES

- Glass passivated chip junction
- Ideally Suited for Automatic Assembly
- Save space on printed circuit boards
- Body Thick Very Thin <1.5mm
- Low Forward Voltage Drop
- Surge Overload Rating to 14A peak
- In compliance with EU RoHS 2002/95/EC directives
- Plastic Material:UL Flammability Classification Rating 94V-0

MECHANICAL DATA

- Case : TDI, Plastic
- Terminals : Solderable per MIL-STD-750, Method 2026
- Polarity: As Marked on case
- Marking: Type number
- Weight: 0.090 grams (Approx.)

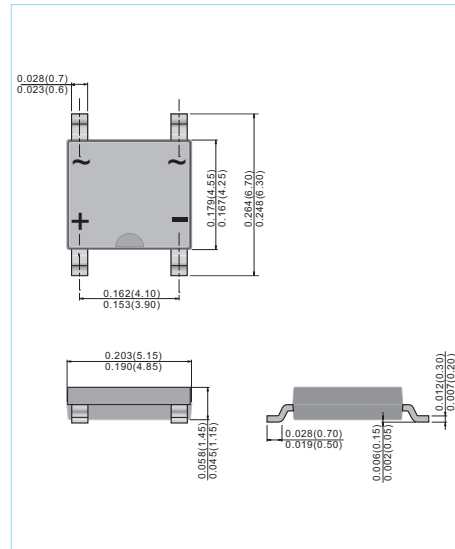

ABSOLUTE MAXIMUM RATINGS (If not specified TA=25°C)

PARAMETER	SYMBOL	CONDITIONS	TB1S-05	TB2S-05	TB4S-05	TB6S-05	TB8S-05	TB10S-05	UNIT
Maximum Recurrent Peak Reverse Voltage	V _{RRM}	-	100	200	400	600	800	1000	V
Maximum RMS Voltage	V _{RMS}	-	70	140	280	420	560	700	V
Maximum DC Blocking Voltage	V _{DC}	-	100	200	400	600	800	1000	V
Average Rectified Forward Current	I _O	60Hz sine wave,R-load,TA=25°C On FR-4 P.C.B Board	0.5						A
Peak Surge Forward Current	I _{FSM}	60Hz sine wave,Non-repetitive 1 cycle peak value,TJ=25°C	14						A
I ² t Rating for fusing (t<8.3ms)	I ² t	-	0.8134						A ² S
Operating Junction Temperature	T _J	-	150						°C
Storage Temperature	T _{STG}	-	-55 to +150						°C

PAN JIT RESERVES THE RIGHT TO CHANGE THE SPECIFICATION ANY TIME WITHOUT NOTICE IN ORDER TO IMPROVE THE DESIGN AND SUPPLY THE BEST POSSIBLE PRODUCT.



TB1S-05~TB10S-05

ELECTRICAL CHARACTERISTICS (If not specified $T_A=25^\circ\text{C}$)

PARAMETER	SYMBOL	CONDITIONS	MAX.	UNIT
Forward Voltage	V_F	$I_F=0.5\text{A}$, Pulse measurement, Rating of per diode	1.1	V
Reverse Current	I_R	At V_{RRM} , Pulse measurement, Rating of per diode	10	μA
Typical Junction capacitance	C_J	$V_R=4\text{V}$, $f=1\text{MHz}$	10	pF
Thermal Resistance	$R_{\theta JC}$	Junction to case	70	$^\circ\text{C}/\text{W}$
	$R_{\theta JA}$	Junction to ambient, On FR-4 P.C.B Board	95	

RATING AND CHARACTERISTIC CURVES

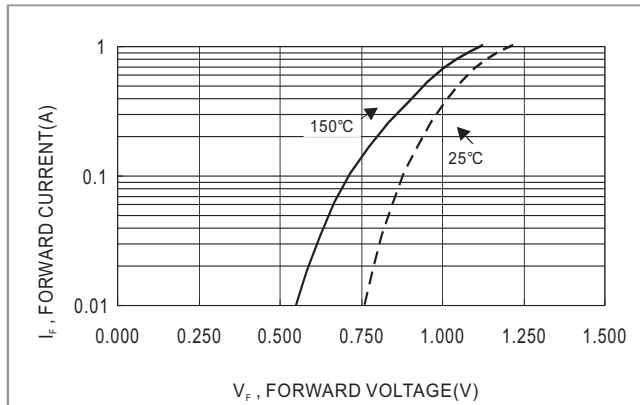

Fig. 1 - TYPICAL FORWARD CHARACTERISTICS

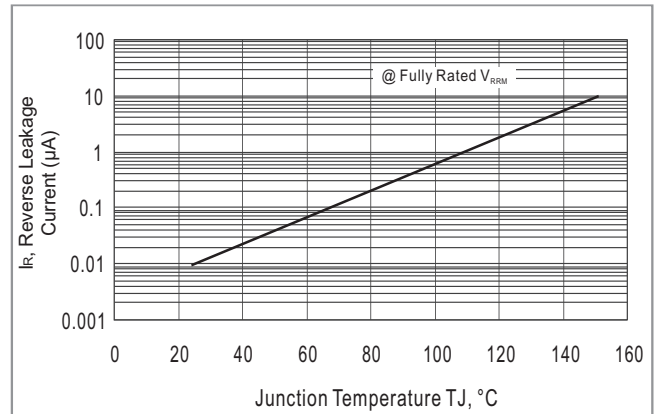

FIG-2 TYPICAL LEAKAGE CURRENT vs JUNCTION TEMPERATURE

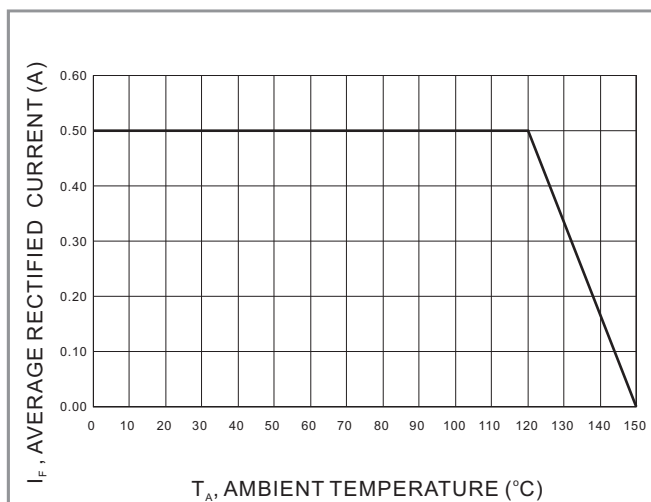
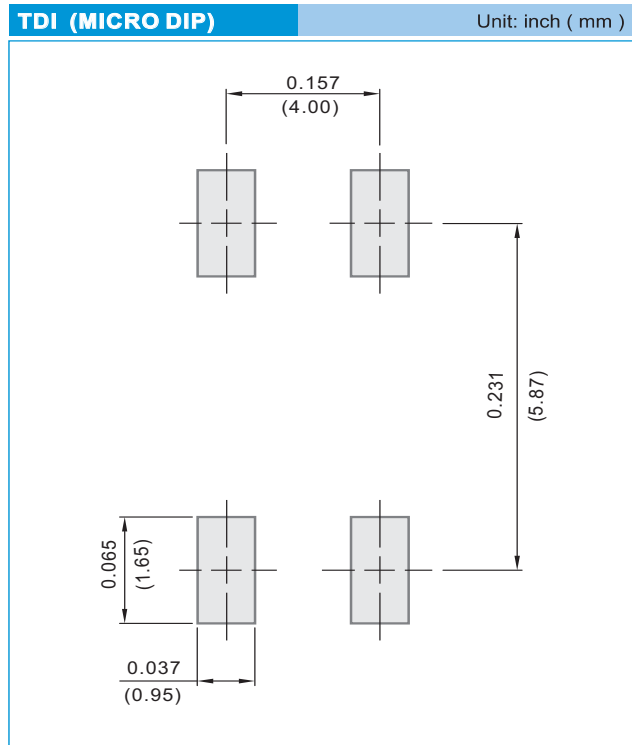

FIG 3- POWER DERATING CURVE



MOUNTING PAD LAYOUT



ORDER INFORMATION

- Packing information
 - T/R - 4K per 13" plastic Reel
 - T/R - 1K per 7" plastic Reel

LEGAL STATEMENT

Copyright PanJit International, Inc 2010

The information presented in this document is believed to be accurate and reliable. The specifications and information herein are subject to change without notice. Pan Jit makes no warranty, representation or guarantee regarding the suitability of its products for any particular purpose. Pan Jit products are not authorized for use in life support devices or systems. Pan Jit does not convey any license under its patent rights or rights of others.



2. MARKING

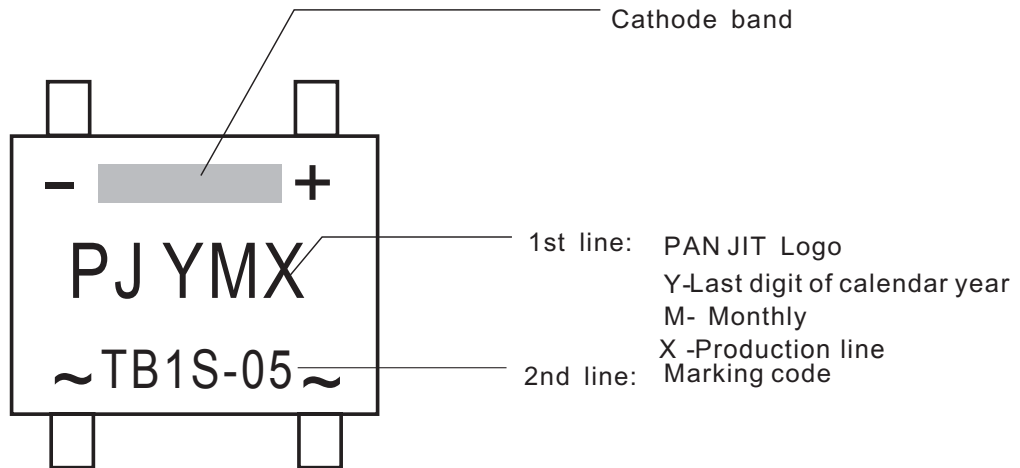



3. TAPING

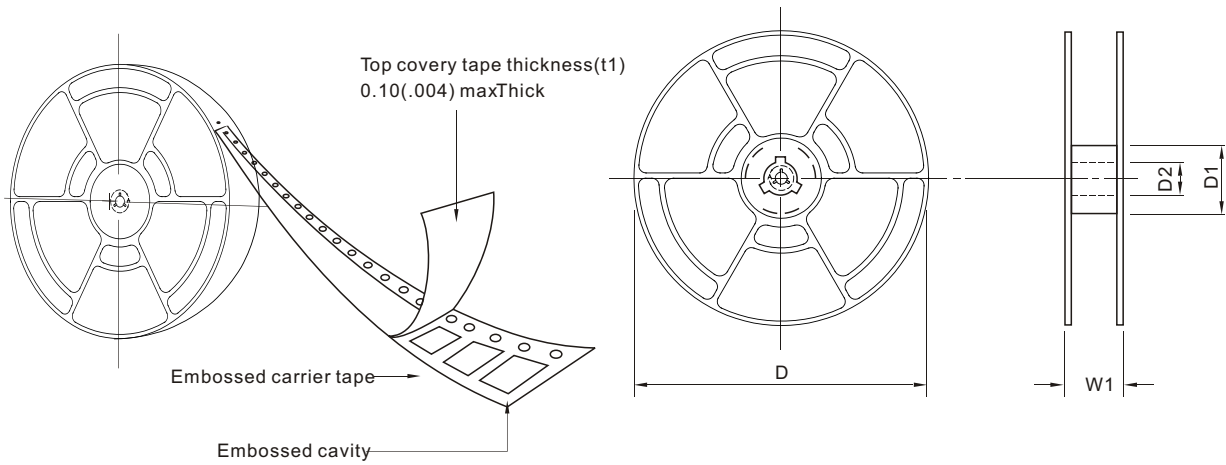
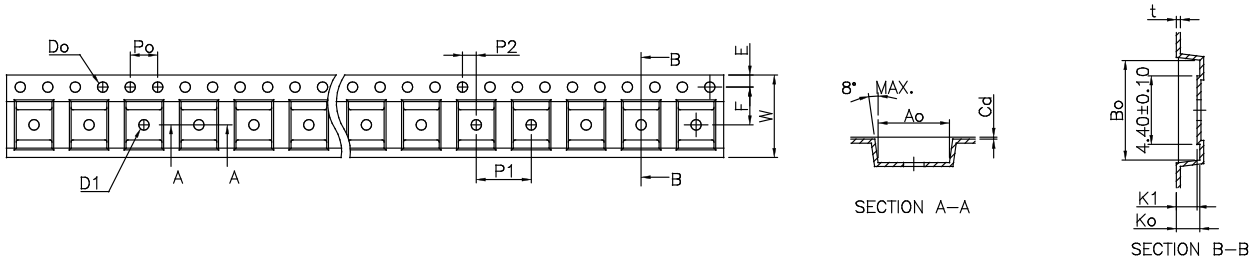

SYMBOL	mm(inch)
TYPE SIZE	12.00 (0.472)
D	330.0 ± 1.0 (13.0 ± 0.039)
Do	1.50 ± 0.10 (0.59 ± 0.004)
D1	101.0 ± 1.0 (4.0 ± 0.039)
E	1.75 ± 0.10 (0.069 ± 0.004)
F	5.50 ± 0.05 (0.21 ± 0.002)
Po	4.00 ± 0.10 (0.15 ± 0.004)
P1	8.00 ± 0.05 (0.31 ± 0.002)
P2	2.00 ± 0.05 (0.07 ± 0.002)
W	12.00 + 3.00 (0.472 + 0.118)
W	12.00 - 1.00 (0.472 - 0.004)
W1	18.40(0.724)

Note:

1. There shall be leader of 230 mm minimum which may consist of carrier and or cover tape follower by a minimum of 160 mm of carrier tape sealed with cover tape.
2. There shall be minimum of 160 mm of empty component pockets sealed with cover tape.
3. Devices are packed in accordance whit EIA standard EIA-481-A and specifications given above.



4. PACKING

REEL PACKING

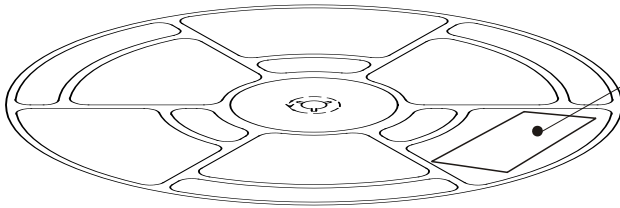

Quantity per Reel:4,000 pcs

LABEL TYPE

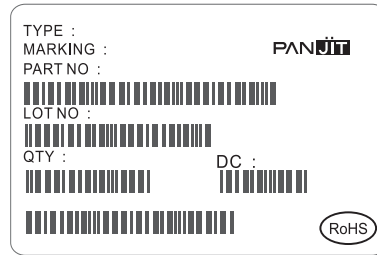

CARTON

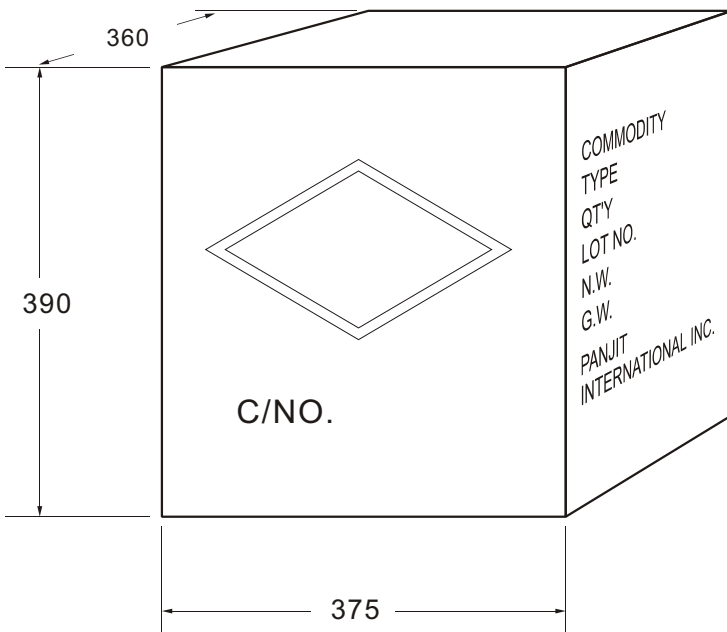

Box Dimensions : mm
Quantity per Box: 64,000pcs

SHIPPING MARK

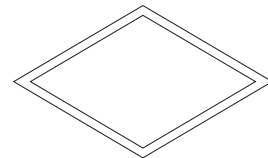

C/NO.
PRODUCT COUNTRY

SIDE MARK

COMMODITY:
TYPE:
Q'TY:
LOT NO.
N.W.
G.W.
PANJIT
INTERNATIONAL INC.



Bulk Packing

PACKAGE	INNER SIZE	BOX	CARTON SIZE	CARTON	APPROX. GROSS WEIGHT
	(m/m)	(EA)	(m/m)	(EA)	(Kg)
Bulk Packing					
A-405	198 x 84 x 20	1,000	459 x 214 x 256	50,000	12.7
AG / RB-10 (WOB)	258 x 190 x 77	1,000	395 x 270 x 400	10,000	15
AM	258 x 190 x 77	1,000	395 x 270 x 400	10,000	15
CM / KBPC	193 x 193 x 46	50	405 x 210 x 265	500	17
CMW / KBPC-W	193 x 193 x 46	50	405 x 210 x 265	500	17
KBPC-P /CP	193 x 193 x 46	50	405 x 210 x 265	500	9.5
KBPC-PW /CPW	193 x 193 x 46	50	405 x 210 x 265	500	9.5
CP-3 / 6 (K-3 / K-6)	219 x 115 x 90	200	600 x 235 x 198	2,000	7.3/8.8
CP-8 / 10 (K-8)	219 x 115 x 90	200	600 x 235 x 198	2,000	13.8
DIP	-	-	495 x 214 x 256	12,000	6.5
DO-15	200 x 85 x 25	1,000	459 x 214 x 256	40,000	20.7
DO-201AD	200 x 85 x 40	500	495 x 214 x 256	12,500	16
DO-201AE	200 x 85 x 40	500	495 x 214 x 256	12,500	16
DO-34	240 x 100 x 90	2,000	406 x 335 x 257	120,000	14.5
DO-35	240 x 100 x 90	2,000	406 x 335 x 257	120,000	17.1
DO-41	198 x 84 x 20	1,000	459 x 214 x 265	50,000	19.3
DO-41G	240 x 100 x 90	1,000	406 x 335 x 257	60,000	18.5
FL	230 x 230 x 50	500	495 x 245 x 180	3,000	18.4
GBJ (TUBE)	556 x 150 x 100	800	578 x 340 x 235	3,200	25.5
GBJ (BOX)	350 x 337 x 44	600	375 x 360 x 213	2,400	14.3
GBL	350 x 337 x 44	960	375 x 360 x 213	3,840	13.1
GBP	350 x 337 x 44	1,120	375 x 360 x 213	4,480	10.6
GBPC	193 x 193 x 46	50	405 x 210 x 265	500	17
GBPCW	193 x 193 x 46	50	405 x 210 x 265	500	17
GBU (TUBE)	488 x 150 x 100	800	510 x 310 x 235	3,200	22.6
GBU (BOX)	350 x 337 x 44	800	375 x 360 x 213	3,200	15.2
KBJ	220 x 176 x 45	200	375 x 230 x 260	2,000	15
KBPF	242 x 208 x 35	500	426 x 252 x 365	10,000	19.2
KBU	276 x 158 x 59	200	493 x 287 x 320	3,000	24
P-600	208 x 90 x 83	500	459 x 214 x 256	5,000	11.3
R-1	198 x 84 x 20	1,000	459 x 214 x 256	50,000	12.7
TO-220	540 x 145 x 85	2,000	555 x 306 x 200	8,000	20.5
ITO-220	540 x 145 x 85	2,000	555 x 306 x 200	8,000	22.9
TO-251AB	555 x 145 x 85	8,400	555 x 306 x 200	33,600	22
TO-3P / TO-247AD	-	-	536 x 243 x 100	1,500	13.9
TO-3PS / TO-247S	-	-	511 x 243 x 107	1,500	12.2



Reel Packing

PACKAGE	REEL SIZE	REEL	COMPONENT SPACE	TAPE SPACE	REEL DIA	CARTON SIZE	CARTON	APPROX. GROSS WEIGHT
	(inch)	(pcs)	(m/m)	(m/m)	(m/m)	(m/m)	(EA)	(Kg)
Reel Packing								
R-1	-	5,000	5.0	52	330	340 x 340 x 410	25,000	7.8
A-405	-	5,000	5.0	52	330	340 x 340 x 410	25,000	11
DO-15	-	4,000	5.0	52	330	340 x 340 x 410	20,000	11.4
DO-201AD	-	1,250	10.0	52	330	340 x 340 x 410	6,250	9.2
DO-201AE	-	1,250	10.0	52	330	340 x 340 x 410	6,250	9.2
DO-34	15	10,000	5.0	52	360	360 x 360 x 395	50,000	10.1
DO-35	15	10,000	5.0	52	360	360 x 360 x 395	50,000	11.2
DO-41	-	5,000	5.0	52	330	340 x 340 x 410	25,000	11.8
DO-41G	15	5,000	5.0	52	360	360 x 360 x 395	25,000	10.9
P-600	-	800	10.0	52	330	340 x 340 x 410	4,000	9.8
DPAK/TO-252	13	3,000	8.0	16	330	375 x 360 x 390	42,000	18.8
D2PAK/TO-263	13	800	16.0	24	330	375 x 360 x 390	6,400	14.4
MDI	13	3,000	8.0	12	330	375 x 360 x 390	48,000	14.7
SDIP	13	1,500	12.0	16	330	375 x 360 x 390	21,000	14.3
QUADRO-MELF	13	10,000	4.0	-	330	360 x 360 x 395	200,000	14.9
QUADRO-MELF	7	2,500	4.0	-	178	385 x 380 x 260	200,000	13.3
MELF/DL-41	13	5,000	4.0	-	330	360 x 360 x 395	100,000	23.5
MELF/DL-41	7	1,500	4.0	-	178	385 x 380 x 260	84,000	18.3
MICRO-MELF	13	10,000	4.0	-	330	360 x 360 x 395	200,000	11.5
MICRO-MELF	7	2,500	4.0	-	178	385 x 380 x 260	200,000	9.3
MINI-MELF	13	10,000	4.0	-	330	360 x 360 x 395	200,000	14.6
MINI-MELF	7	2500	4.0	-	178	385 x 380 x 260	200,000	12.7
SMA	13	7,500	4.0	12	330	375 x 360 x 390	120,000	17.3
SMA	7	1,800	4.0	12	178	390 x 240 x 420	72,000	10
SMB	13	3,000	8.0	12	330	375 x 360 x 390	48,000	13.2
SMB	7	500	8.0	12	178	390 x 240 x 420	20,000	6.5
SMC	13	3,000	8.0	16	330	375 x 360 x 390	42,000	18
SMC	7	500	8.0	16	178	390 x 240 x 420	15,000	8.3
SOD-123	13	10,000	4.0	8	330	375 x 360 x 213	120,000	6.5
SOD-123	7	3,000	4.0	8	178	390 x 270 x 400	240,000	9.9
SOD-123FL	13	10,000	4.0	8	330	375 x 360 x 213	120,000	7.2
SOD-123FL	7	3,000	4.0	8	178	390 x 270 x 400	240,000	10.6



Reel Packing

PACKAGE	REEL SIZE	REEL	COMPONENT SPACE	TAPE SPACE	REEL DIA	CARTON SIZE	CARTON	APPROX. GROSS WEIGHT
	(inch)	(pcs)	(m/m)	(m/m)	(m/m)	(m/m)	(EA)	(Kg)
Reel Packing								
SOD-323	13	12,000	4.0	8	330	375 x 360 x 213	144,000	5.9
SOD-323	7	5,000	4.0	8	178	390 x 270 x 400	400,000	9.4
SOD-523	13	12,000	4.0	8	330	375 x 360 x 213	144,000	5.4
SOD-523	7	5,000	4.0	8	178	390 x 270 x 400	400,000	9.1
SOD-723	7	8,000	2.0	8	178	390 x 270 x 400	640,000	8.5
SOD-923	7	8,000	2.0	8	178	390 x 270 x 400	640,000	7.7
SOT-23	13	12,000	4.0	8	330	375 x 360 x 213	144,000	7
SOT-23	7	3,000	4.0	8	178	390 x 270 x 400	240,000	8.3
SOT-323	13	12,000	4.0	8	330	375 x 360 x 213	144,000	6.1
SOT-323	7	3,000	4.0	8	178	390 x 270 x 400	240,000	7.9
SOT-363	13	10,000	4.0	8	330	375 x 360 x 213	120,000	7.1
SOT-363	7	3,000	4.0	8	178	390 x 270 x 400	240,000	10.2
SOT-23 (ESD)	7	3,000	4.0	8	178	455 x 270 x 440	240,000	9.5
SOT-323 (ESD)	7	3,000	4.0	8	178	455 x 270 x 440	240,000	9.1
SOT-363 (ESD)	7	3,000	4.0	8	178	455 x 270 x 440	240,000	10
SOT-353	13	10,000	4.0	8	330	375 x 360 x 213	120,000	7.2
SOT-353	7	3,000	4.0	8	178	390 x 270 x 400	240,000	10
SOT-553	13	10,000	4.0	8	330	375 x 360 x 213	120,000	5.2
SOT-553	7	4,000	4.0	8	178	390 x 270 x 400	320,000	9.4
SOT-563	13	10,000	4.0	8	330	375 x 360 x 213	120,000	5.2
SOT-563	7	4,000	4.0	8	178	390 x 270 x 400	320,000	9.4
SOT23-5L	13	10,000	4.0	8	330	375 x 360 x 213	120,000	7.9
SOT23-5L	7	3,000	4.0	8	178	390 x 270 x 400	240,000	14.5
SOT23-6L	13	10,000	4.0	8	330	375 x 360 x 213	120,000	7.9
SOT23-6L	7	3,000	4.0	8	178	390 x 270 x 400	240,000	14.5
SOT-143	13	10,000	4.0	8	330	375 x 360 x 213	120,000	7
SOT-143	7	3,000	4.0	8	178	390 x 270 x 400	240,000	12.8
SOIC-08	13	3,000	8.0	12	330	375 x 360 x 213	48,000	14.2
QFN 1.2 x 1.5	7	3,000	4.0	8	178	390 x 270 x 400	240,000	7.1
QFN 1.6 x 1.6	7	4,000	4.0	8	178	390 x 240 x 420	200,000	7.8
QFN 2.0 x 2.0	7	3,000	4.0	8	178	390 x 270 x 400	240,000	7.1



Ammunition Packing

PACKAGE	AMMO	COMPONENT SPACE	TAPE SPACE	BOX SIZE	CARTON	CARTON	APPROX. GROSS WEIGHT
	(PCS)	(m/m)	(m/m)	(m/m)	(m/m)	(E/A)	(Kg)
Ammunition Packing							
A-405	5,000	5	26	255 x 47 x 150	339 x 276 x 330	60,000	12.4
A-405	5,000	5	52	255 x 75 x 150	339 x 276 x 330	40,000	16
DO-15	3,000	5	52	255 x 75 x 150	339 x 276 x 330	24,000	13.3
DO-201AD	1,250	10	52	255 x 47 x 122	339 x 276 x 330	10,000	13.4
DO-201AE	1,250	10	52	255 x 47 x 122	339 x 276 x 330	10,000	13.4
DO-34	5,000	5	26	248 x 80 x 48	406 x 335 x 257	150,000	14.6
DO-34	5,000	5	52	248 x 80 x 75	406 x 335 x 257	100,000	12.7
DO-35	5,000	5	26	248 x 80 x 48	406 x 335 x 257	150,000	16.7
DO-35	5,000	5	52	248 x 80 x 75	406 x 335 x 257	100,000	15.2
DO-41	5,000	5	52	255 x 75 x 150	339 x 276 x 330	40,000	16
DO-41G	2,500	5	26	248 x 80 x 48	406 x 335 x 257	75,000	17.1
DO-41G	2,500	5	52	248 x 80 x 75	406 x 335 x 257	50,000	15.7
P-600	400	10	52	255 x 47 x 122	339 x 276 x 330	3,200	8.1
R-1	3,000	5	26	255 x 47 x 73	310 x 268 x 170	36,000	6.3
R-1	3,000	5	52	256 x 73 x 73	310 x 268 x 170	24,000	6.4
R-1	5,000	5	52	255 x 73 x 122	339 x 276 x 274	40,000	10.3

HIGH RELIABILITY TEST SPEC

(Schottky & Switching & Rectifiers & Bridge)

Date : 2010.04.29 rev.00

NO.	TEST ITEM	TEST CONDITION	REFERENCED DOCUMENT	LOT QUALITY LEVEL
1	TEMPERATURE CYCLING (T.C.T) 溫度循環試驗	Ta = -55+0°C / -10°C 10min(Min) Ta = +150+15°C / -0°C 10min(Min) FOR 20CYCLES	MIL-STD-750D METHOD-1051.5 Condition G	LTPD 10 S.s=22 ACCEPT FOR 0 FAILURE ONLY.
2	HIGH TEMPERATURE STORAGE LIFE (H.T.S.L) 高溫儲存壽命試驗	Ta=Storage Temperature Range (device specified maximum temperature)	MIL-STD-750D METHOD-1032.2	LTPD 10 S.s=22 ACCEPT FOR 0 FAILURE ONLY.
3	SOLDERABILITY TEST 錫錫性試驗	Temperature of Solder TEMPERATURE OF SOLDER POT=245+/-5°C TIME FOR DIPPING IN SOLDER=5+/-0.5 SEC DIPPING DEPTH=0.05inch max from the body FOR ONE CYCLE	MIL-STD-750D METHOD-2026.10	LTPD 7 S.s=32 ACCEPT FOR 0 FAILURE ONLY.
4	HIGH TEMPERATURE REVERSE BIAS (H.T.R.B) 高溫逆向偏壓	Tj ≤ Tj max VR=0.8VR(CUSTOMER SPEC.) DC supply	MIL-STD-750D METHOD-1038.3	LTPD 10 S.s=22 ACCEPT FOR 0 FAILURE ONLY.
5	CONTINUE FORWARD OPERATING LIFE(C.F.O.L) 連續通電	Ta=25°C I=Io+/-10% DC supply	MIL-STD-750D METHOD 1027.3	LTPD 10 S.s=22 ACCEPT FOR 0 FAILURE ONLY.
6	THERMAL SHOCK (T.S.T) 冷熱衝擊試驗	HOT TANK Ta=100+10/-2°C t= 5min COLD TANK Ta=0+2/-10°C t= 5min 15 CYCLES TIME BETWEEN TRANSFERRING DO NOT EXCEED 10 SEC	MIL-STD-750D METHOD 1056.7	LTPD 10 S.s=22 ACCEPT FOR 0 FAILURE ONLY.
7	PRESSURE COOKER (P.C.T) 壓力鍋試驗	Ta=121°C P=29.7psia / 205kPa or 2.088kg/cm ² Relative Humidity = 100%	JEDEC JESD22-A102-C	LTPD 10 S.s=22 ACCEPT FOR 0 FAILURE ONLY.
8	INTERMITTENT FORWARD OPERATING LIFE (I.F.O.L) 斷續通電	I=Io x 1.0 DC supply POWER ON: at least 30 SEC POWER OFF: 50 SEC TESTING CYCLE: 2000CYCLES	MIL-STD-750D METHOD 1036.3	DC POWER SUPPLY TIMER
9	FORWARD SURGE CURRENT 順向突波電流測試	SQ WAVE OR SINE WAVE IFSM=DATE SHEET SPEC. TIME=Single half sine wave T=1 CYCLE	MIL-STD-750D METHOD 4066-3	LTPD 10 S.s=22 ACCEPT FOR 0 FAILURE ONLY.
10	HUMIDITY 恆溫濕試驗	Ta=85+/-2°C RH=85+/-5%	EIAJ ED-4701 METHOD B-121	LTPD 10 S.s=22 ACCEPT FOR 0 FAILURE ONLY.
11	SOLDER RESISTANCE 錫錫耐熱性試驗	TEMPERATURE OF SOLDER POT=260+/-5°C TIME FOR DIPPING IN SOLDER=10+2/-0 SEC DIPPING DEPTH=1.57+/-0.79mm FROM THE BODY FOR ONE CYCLE	MIL-STD-750D METHOD 2031.2	LTPD 10 S.s=22 ACCEPT FOR 0 FAILURE ONLY.