



MB14~MB120

SURFACE MOUNT SCHOTTKY BARRIER RECTIFIER

VOLTAGE 40 to 200 Volts **CURRENT** 1.0 Ampere

SMB / DO-214AA

Unit: inch (mm)

FEATURES

- Plastic package has Underwriters Laboratory Flammability Classification 94V-O
- For surface mounted applications
- Low profile package
- Built-in strain relief
- Metal to silicon rectifier. majority carrier conduction
- Low power loss, high efficiency
- High surge capacity
- High current capacity, low V_F
- For use in low voltage high frequency inverters, free wheeling, and polarity protection applications.
- In compliance with EU RoHS 2002/95/EC directives

MECHANICAL DATA

- Case: JEDEC DO-214AA molded plastic
- Terminals: Solder plated, solderable per MIL-STD-750, Method 2026
- Polarity: Color band denotes positive end (cathode)
- Standard packaging: 12mm tape (EIA-481)
- Weight: 0.0032 ounce, 0.092 gram

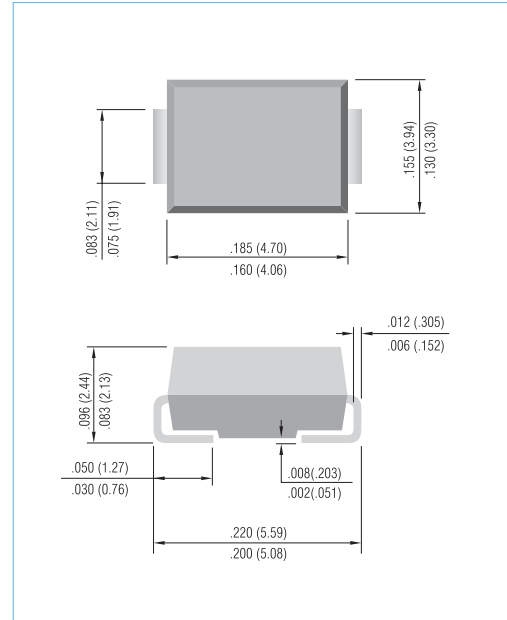

MAXIMUM RATINGS AND ELECTRICAL CHARACTERISTICS

Ratings at 25°C ambient temperature unless otherwise specified. Single phase, half wave, 60 Hz, resistive or inductive load.

PARAMETER	SYMBOL	MB14	MB14A	MB15	MB16	MB18	MB19	MB110	MB115	MB120	UNITS
Maximum Recurrent Peak Reverse Voltage	V_{RRM}	40	45	50	60	80	90	100	150	200	V
Maximum RMS Voltage	V_{RMS}	28	31.5	35	42	56	63	70	105	140	V
Maximum DC Blocking Voltage	V_{DC}	40	45	50	60	80	90	100	150	200	V
Maximum Average Forward Current (See Figure 1)	$I_{F(AV)}$	1.0									A
Peak Forward Surge Current :8.3ms single half sine-wave superimposed on rated load(JEDEC method)	I_{FSM}	30									A
Maximum Forward Voltage at 1.0A (Note 1)	V_F	0.7		0.74		0.80		0.9			V
Maximum DC Reverse Current $T_J=25^{\circ}C$ at Rated DC Blocking Voltage $T_J=100^{\circ}C$	I_R					0.05					mA
Typical Thermal Resistance (Note 2)	$R_{\theta JL}$					30					$^{\circ}C / W$
	$R_{\theta JA}$					95					
Operating Junction and Storage Temperature Range	T_J, T_{STG}	-55 to +150				-65 to +175					$^{\circ}C$

NOTES:

1. Pulse Test with PW =300µsec, 1% Duty Cycle.
2. Mounted on P.C. Board with 5.0mm² (.013mm thick) copper pad areas.

PRELIMINARY



MB14~MB120

RATING AND CHARACTERISTIC CURVES

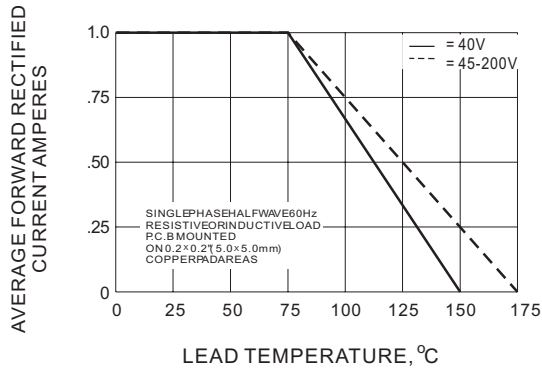

Fig. 1-FORWARD CURRENT DERATING CURVE

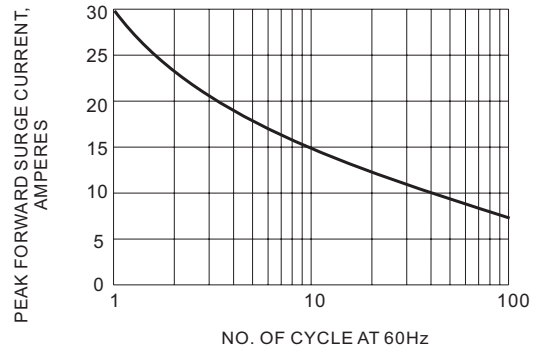

Fig. 2- MAXIMUM NON-REPETITIVE PEAK FORWARD SURGE CURRENT

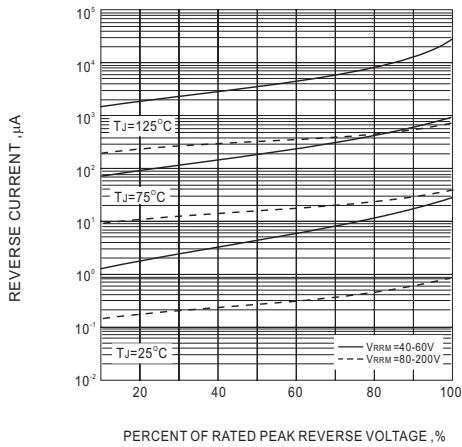

Fig. 3-TYPICAL REVERSE CHARACTERISTIC

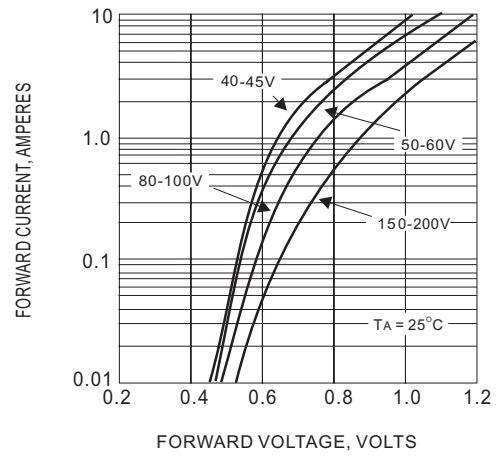

Fig. 4-TYPICAL INSTANTANEOUS FORWARD CHARACTERISTIC

PRELIMINARY



MB14~MB120

MOUNTING PAD LAYOUT

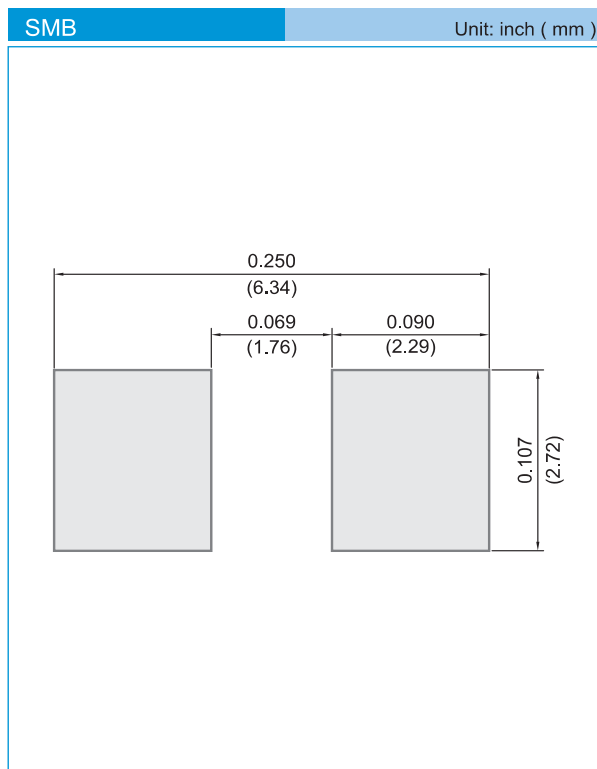

ORDER INFORMATION

- Packing information
 - T/R - 3K per 13" plastic Reel
 - T/R - 0.5K per 7" plastic Reel

LEGAL STATEMENT

Copyright PanJit International, Inc 2009

The information presented in this document is believed to be accurate and reliable. The specifications and information herein are subject to change without notice. Pan Jit makes no warranty, representation or guarantee regarding the suitability of its products for any particular purpose. Pan Jit products are not authorized for use in life support devices or systems. Pan Jit does not convey any license under its patent rights or rights of others.

PRELIMINARY