



TABLE OF CONTENTS

1.DATA SHEET PAGE 1

2.MARKING PAGE 3

3.PACKING PAGE 4

4.HIGH RELIABILITY TESTING SPEC. PAGE 7



1.DATA SHEET

UF800F~UF808F

ISOLATION ULTRAFAST RECOVERY RECTIFIERS

VOLTAGE 50 to 800 Volts **CURRENT** 8.0 Amperes

ITO-220AC

Unit : inch (mm)

FEATURES

- Plastic package has Underwriters Laboratory Flammability Classification 94V-O utilizing Flame Retardant Epoxy Molding Compound.
- Exceeds environmental standards of MIL-S-19500/228
- Low power loss, high efficiency.
- Low forward voltage, high current capability
- High surge capacity.
- Ultra fast recovery times, high voltage.
- Pb free product are available : 99% Sn above can meet RoHS environment substance directive request

MECHANICAL DATA

Case: ITO-220AC full molded plastic package

Terminals: Lead solderable per MIL-STD-202G, Method 208

Polarity: As marked.

Standard packaging: Any

Weight: 0.08 ounces, 2.24grams.

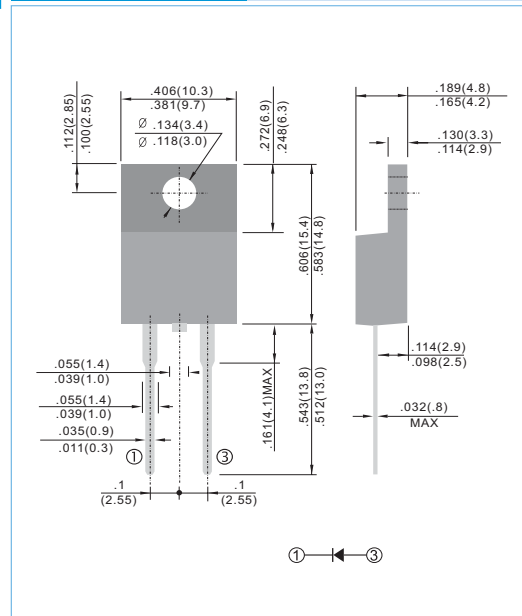

MAXIMUM RATINGS AND ELECTRICAL CHARACTERISTICS

Ratings at 25°C ambient temperature unless otherwise specified. Single phase, half wave, 60 Hz, resistive or inductive load.

For capacitive load, derate current by 20%

PARAMETER	SYMBOL	UF800F	UF801F	UF802F	UF803F	UF804F	UF806F	UF808F	UNITS	
Maximum Recurrent Peak Reverse Voltage	V _{RRM}	50	100	200	300	400	600	800	V	
Maximum RMS Voltage	V _{RMS}	35	70	140	210	280	420	560	V	
Maximum DC Blocking Voltage	V _{DC}	50	100	200	300	400	600	800	V	
Maximum Average Forward Rectified Current at T _c =100°C	I _{AV}	8.0								A
Peak Forward Surge Current : 8.3ms single half sine-wave superimposed on rated load(JEDEC method)	I _{FSM}	125								A
Maximum Forward Voltage at 8.0A	V _F		1.0		1.3		1.7		V	
Maximum DC Reverse Current T _A =25°C at Rated DC Blocking Voltage T _A =125°C	I _R				10				uA	
					500					
Maximum Thermal Resistance (Note 2)	R _{θJC}	5								°C / W
Typical Junction Capacitance	C _J			80			50		pF	
Maximum Reverse Recovery Time (Note 1)	T _{RR}			50			100		ns	
Operating Junction and Storage Temperature Range	T _J , T _{STG}	-50 to +150								°C

NOTES:

1. Reverse Recovery Test Conditions: I_F=.5A, I_R=1A, I_{rr}=.25A.

2. Thermal resistance from Junction to ambient and from junction to lead 0.375" (9.5mm) P.C.B mounted.



RATING AND CHARACTERISTIC CURVES

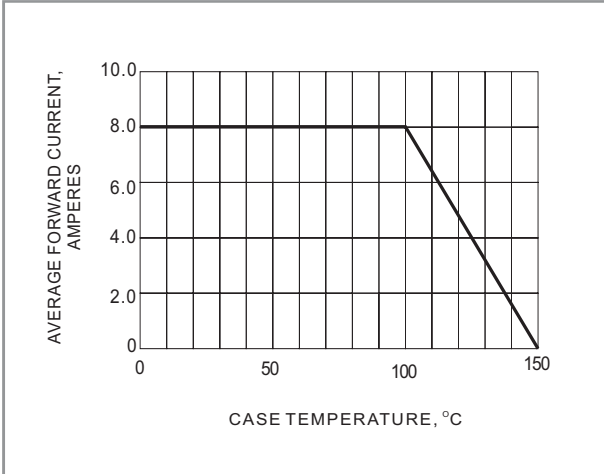

Fig.1 FORWARD CURRENT DERATING CURVE

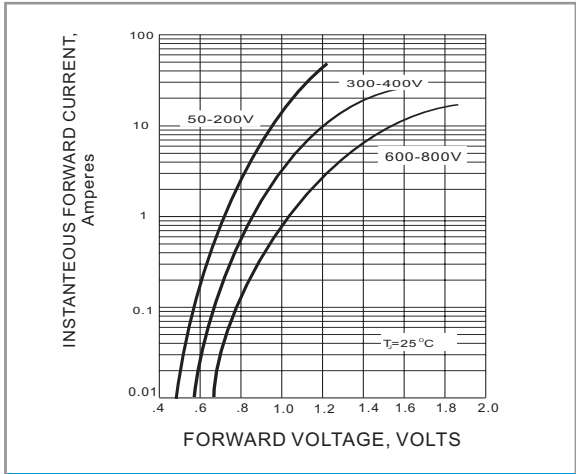

Fig.2 FORWARD CHARACTERISTICS

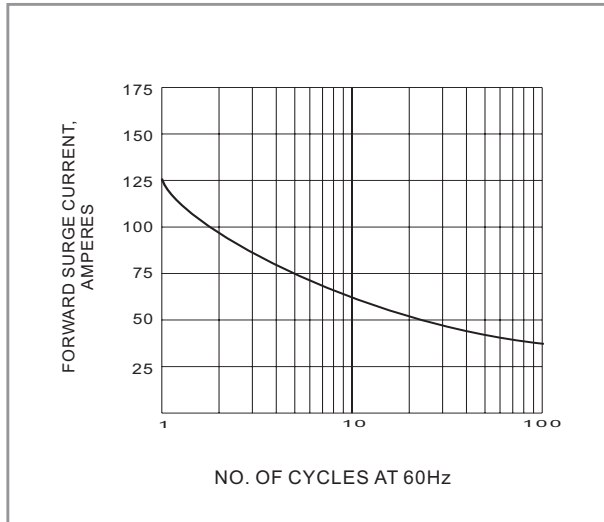

Fig.3 PEAK FORWARD SURGE CURRENT

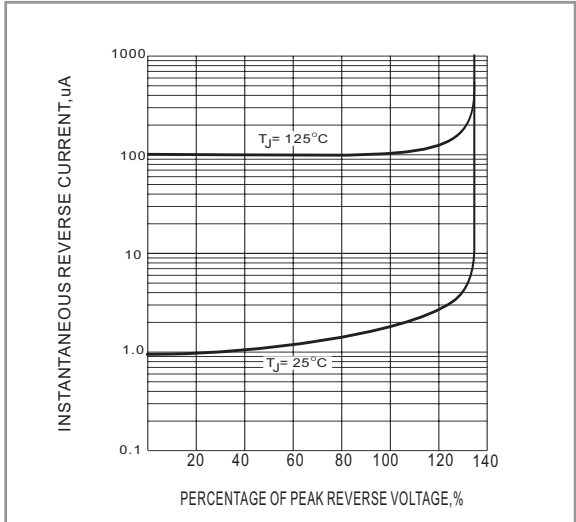
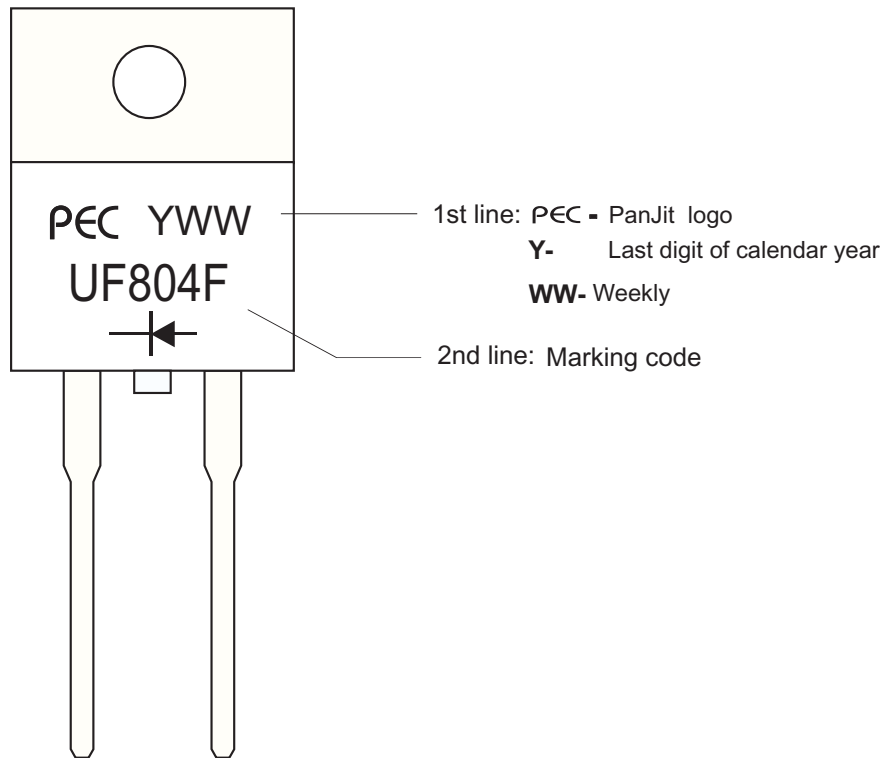

Fig.4 TYPICAL REVERSE CHARACTERISTICS



2. MARKING





3. PACKING

INNER BOX

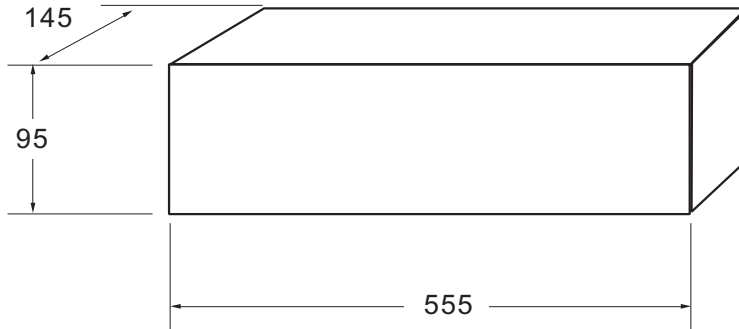

Box Dimensions : mm
Quantity per Carton: 2,000 pcs

CARTON

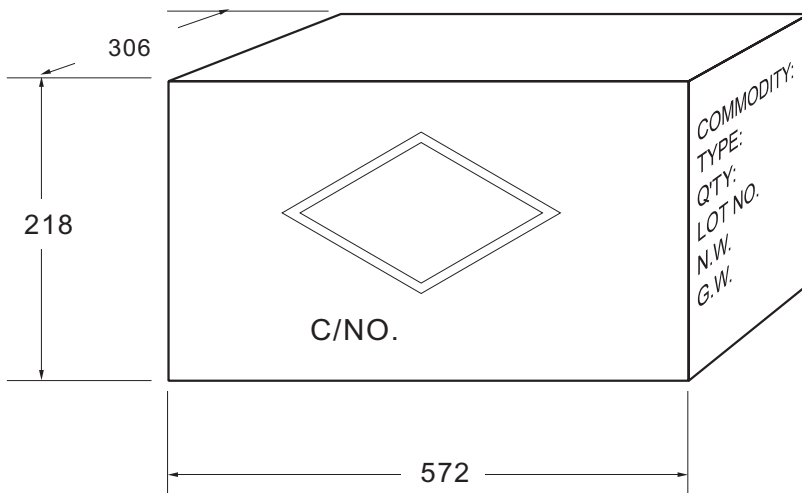

Box Dimensions : mm
Quantity per Box: 8,000 pcs

SHIPPING MARK

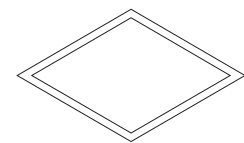

C/NO.
PRODUCT COUNTRY

SIDE MARK

COMMODITY:
TYPE:
Q'TY:
LOT NO.
N.W.
G.W.
PANJIT
INTERNATIONAL INC.



Bulk Packing

PACKAGE	INNER SIZE	BOX	CARTON SIZE	CARTON	APPROX. GROSS WEIGHT
	(m/m)	(EA)	(m/m)	(EA)	(Kg)
Bulk Packing					
R-1	198 x 84 x 20	1,000	459 x 214 x 256	50,000	12.4
A-405	198 x 84 x 20	1,000	459 x 214 x 256	50,000	13.4
DO-35	96 x 80 x 42	10,000	410 x 350 x 275	120,000	21.5
DO-34	96 x 80 x 42	10,000	410 x 350 x 275	120,000	21.5
DO-41G	240 x 100 x 100	5,000	410 x 350 x 275	60,000	26.5
DO-41	198 x 84 x 20	1,000	459 x 214 x 256	50,000	19.1
DO-15	200 x 85 x 25	1,000	459 x 214 x 256	40,000	17.5
DO-201AE	200 x 85 x 40	500	459 x 214 x 256	12,500	17.0
DO-201AD	200 x 85 x 40	500	459 x 214 x 256	12,500	17.3
P600	208 x 90 x 83	500	459 x 214 x 256	5,000	11.3
AM	195 x 195 x 40	1,000	400 x 273 x 415	10,000	16.8
DIP	-	-	459 x 214 x 256	12,000	10.2
SDIP	-	-	459 x 214 x 256	24,000	15.5
FL	230 x 230 x 50	500	495 x 245 x 180	3,000	25.0
GBU	350 x 337 x 44	800	510 x 340 x 235	3,200	18.9
ITO/TO-220	555 x 145 x 95	2,000	570 x 306 x 218	8,000	13.4
GL	260 x 190 x 75	72	460 x 215 x 260	864	15.8
KBU	230 x 230 x 50	200	495 x 245 x 180	3,000	21.5
GBJ	352 x 337 x 44	600	375 x 360 x 213	2,400	13.1
TO-251AB	560 x 210 x 79	8,000	577 x 226 x 196	16,000	6.5
GBL	352 x 337 x 44	960	375 x 360 x 213	3,840	13.0
GBP	352 x 337 x 44	1,120	375 x 360 x 213	4,480	11.3
TO-3P	-	-	536 x 243 x 100	1,500	12.7
GBPC/W	195 x 195 x 41	50	460 x 215 x 260	500	9.8 / 8.8

Ammunition Packing

PACKAGE	AMMO	COMPONENT SPACE	TAPE SPACE	BOX SIZE	CARTON	CARTON	APPROX. GROSS WEIGHT
	(PCS)	(m/m)	(m/m)	(m/m)	(m/m)	(E/A)	(Kg)
Ammunition Packing							
R-1	5,000	5.0	26	255 x 50 x 150	339 x 276 x 330	60,000	12.4
R-1	5,000	5.0	52	255 x 75 x 150	339 x 276 x 330	40,000	12.4
A-405	5,000	5.0	26	255 x 50 x 150	339 x 276 x 330	60,000	13.4
A-405	5,000	5.0	52	255 x 75 x 150	339 x 276 x 330	40,000	13.4
DO-35	5,000	5.0	52	255 x 80 x 80	410 x 350 x 275	100,000	20.0
DO-34	5,000	5.0	26	248 x 80 x 48	410 x 335 x 265	150,000	15.5
DO-34	5,000	5.0	52	248 x 80 x 75	410 x 335 x 265	5,000	14.1
DO-41G	2,500	5.0	52	255 x 80 x 80	410 x 350 x 275	50,000	22.0
DO-41	5,000	5.0	52	255 x 75 x 150	339 x 276 x 330	40,000	19.1
DO-15	3,000	5.0	52	255 x 75 x 150	339 x 276 x 330	24,000	17.5
DO-201AE	1,250	10.0	52	255 x 75 x 150	339 x 276 x 330	10,000	17.0
DO-201AD	1,250	10.0	52	255 x 75 x 150	339 x 276 x 330	10,000	17.3
P600	400	10.0	52	255 x 75 x 150	339 x 276 x 330	3,200	11.3



PACKAGE	REEL	COMPONENT SPACE	TAPE SPACE	REEL DIA	CARTON SIZE	CARTON	APPROX. GROSS WEIGHT
	(pcs)	(m/m)	(m/m)	(m/m)	(m/m)	(EA)	(Kg)
Reel Packing							
R-1	5,000	5.0	52	330	340 x 340 x 410	25,000	9.0
A-405	5,000	5.0	52	330	340 x 340 x 410	25,000	9.1
DO-34	10,000	5.0	52	360	360 x 360 x 395	50,000	9.5
DO-35	10,000	5.0	52	360	360 x 360 x 395	50,000	12.0
DO-41G	5,000	5.0	52	360	380 x 380 x 420	25,000	14.5
DO-41	5,000	5.0	52	330	360 x 360 x 395	25,000	13.0
DO-15	4,000	5.0	52	330	340 x 340 x 410	20,000	11.8
DO-201AE	1,250	10.0	52	330	340 x 340 x 410	6,250	11.0
DO-201AD	1,250	10.0	52	330	340 x 340 x 410	6,250	11.6
P600	800	10.0	52	330	340 x 340 x 410	4,000	11.4
SMA	7,500 / 1,800	4.0	-	330 / 178	375 x 360 x 390 / 390 x 240 x 420	120,000 / 72,000	17.5 / 8.3
SMB	3,000 / 500	4.0	-	330 / 178	375 x 360 x 390 / 390 x 240 x 420	48,000 / 20,000	13.6 / 7.5
SMC	3,000 / 500	12.0	-	330 / 178	375 x 360 x 390 / 390 x 240 x 420	42,000 / 15,000	16.2 / 7.3
SDIP	1,500	12.0	-	330	375 x 360 x 390	21,000	16.3
MDI	3,000 / 500	8.0	-	330 / 178	375 x 360 x 390	48,000 / 30,000	14.4
D ² PCK	800	16.0	-	330	375 x 360 x 390	6,400	15.6
TO-252	3,000	8.0	-	330	375 x 360 x 390	42,000	16.5
QFN 1.6 x 1.6	12,000 / 4,000	4.0	8	330/178	375 x 360 x 213 / 390 x 240 x 420	144,000 / 200,000	9.2 / 9.6
SOD-123	10,000 / 3,000	4.0	8	330 / 178	375 x 360 x 213 / 390 x 240 x 420	120,000 / 150,000	8.0 / 10.0
SOD-123FL	10,000 / 3,000	4.0	8	330 / 178	375 x 360 x 213 / 390 x 240 x 420	120,000 / 150,000	10.4 / 11.0
SOD-323	12,000 / 5,000	4.0	8	330 / 178	375 x 360 x 213 / 390 x 240 x 420	144,000 / 250,000	9.6 / 10.0
SOT-23	12,000 / 3,000	4.0	8	330 / 178	375 x 360 x 213 / 390 x 240 x 420	144,000 / 150,000	9.6 / 10.0
SOT-323	12,000 / 3,000	4.0	8	330 / 178	375 x 360 x 213 / 390 x 240 x 420	144,000 / 150,000	9.6 / 10.0
SOT-363	3,000	4.0	-	178	438 x 438 x 220	120,000	-
SOT-23-6L	3,000	4.0	-	178	438 x 438 x 220	120,000	-
MICRO-MELF	2,500	4.0	-	178	385 x 380 x 260	25,000	13.5
QUADRO-MELF	2,500	4.0	-	178	640 x 405 x 150	200,000	15.7
MINI-MELF	2,500	4.0	-	178	385 x 380 x 260	25,000	13.5
DL-41	1,500 / 5,000	4.0	-	330	385 x 380 x 260 / 360 x 360 x 395	100,000	14.0



4. HIGH RELIABILITY TESTING SPEC.

NO	TEST ITEM	TEST CONDITION	REFERENCE DOCUMENT	LOT QUALITY LEVEL	REMARK
1	TEMPERATURE CYCLING (T.C.T)	Ta= -55+0,-3°C 10min Ta= +150+/-°C 10min FOR 20 CYCLE	MIL - STD - 750D METHOD - 1051.5	LTPD 10 S.s.=22 ACCEPT FOR 0 FAILURE ONLY.	
2	HIGH TEMPERATURE STORAGE LIFE (H.T.S.L)	Ta=150 +/- 5°C TESTING TIME: 168HRS 250HRS 500HRS	MIL-STD-750D METHOD-1031.2	LTPD10 S.s.=22 ACCEPT FOR 0 FAILURE ONLY.	
3	SOLDERABILITY TEST	TEMPERATURE OF SOLDER POT=260 +/- 5 TIME FOR DIPPING FLUX=5-10SEC TIME FOR DIPPING IN SOLDER=5+/-0. 5SEC DIPPING DEPTH=0.05 inch max FOR ONE CYCLE	MIL-STD-750D	METHOD-2026.10 LTPD 7 S.s.=32 ACCEPT FOR 0 FAILURE ONLY.	
4	HIGH TEMPERATURE REVERSE BIAS (H.T.R.B)	Ta=150 +/- 5°C VR=80%VR(CUSTOM SECP) TESTING TIME: 48HRS 96HRS 168HRS 250HRS 500HRS	MIL-STD-750D METHOD-1038.3	LTPD10 S.s.=22 ACCEPT FOR 0 FAILURE ONLY.	
5	CONTINUE FORWARD OPERATING LIFE (C.F.O.L)	Ta=55 °C I=IO +/-10% TESTING TIME: 168HRS 250HRS 500HRS	MIL-STD-750D METHOD-1027.3	LTPD10 S.s.=22 ACCEPT FOR 0 FAILURE ONLY.	
6	THERMAL SHOCK (T.S.T)	HOT TANK T=100°C+10/-2°C t=5min COLD TANK T=0°C+2/-10°C t=5min 15 CYCLE TIME BETWEEN TRANSFERRING DO'NOT EXCEED 10 SECOND.	MIL-STD-750D METHOD-1056.7	LTPD10 S.s.=22 ACCEPT FOR 0 FAILURE ONLY.	
7	PRESSURE COOKER (P.C.T)	Ta=121°C P=1.2kg/cm ² TIME=96HRS	JEDEC JESD22-A102-C	LTPD10 S.s.=22 ACCEPT FOR 0 FAILURE ONLY.	
8	INTERMITTENT FORWARD OPERATING LIFE (I.F.O.L)	I = Io x 1.0 POWER ON : 30SEC POWER OFF : 50SEC TESTING TIME: 2000 CYCLES	MIL-STD-750D METHOD 1036.3	LTPD10 S.s.=22 ACCEPT FOR 0 FAILURE ONLY.	
9	FORWARD SURGE CURRENT (I.F.S.M)	SQ WAVE OR SINE WAVE IFSM=DATE SHEET SPEC. TIME=8.3Msec T=1 CYCLE	MIL-STD-750D METHOD 4066.3	LTPD10 S.s.=22 ACCEPT FOR 0 FAILURE ONLY.	
10	HUMIDITY	Ta=85°C RH=85% TESTING TIME: 168HRS 250HRS 500HRS	MIL-STD-750D METHOD 1021.1	LTPD10 S.s.=22 ACCEPT FOR 0 FAILURE ONLY.	
11	SOLDERABILITY RESISTANCE	TEMPERATURE OF SOLDER POT =260+/-5°C TIME FOR DIPPING IN SOLDER =10+2/-0 SEC DIPPING DEPTH=1.57+0.79 mm BELOW BODY FOR ONE CYCLE	MIL-STD-750D METHOD 2031.1	LTPD10 S.s.=22 ACCEPT FOR 0 FAILURE ONLY.	

SCHOTTKY PRODUCT TESTING TEMPERATURE 125 °C MAX(NORMAL)