



TABLE OF CONTENTS

1.DATA SHEET

PAGE 1

2.MARKING

PAGE 3

3.TAPING

PAGE 4

4.PACKING

PAGE 5

5.HIGH RELIABILITY TEST SPEC.

PAGE 10



UF200 ~ UF2010

ULTRAFAST SWITCHING RECTIFIER

VOLTAGE 50 to 1000 Volts **CURRENT** 2.0 Amperes

DO-15 Unit: inch(mm)

FEATURES

- Plastic package has Underwriters Laboratory Flammability Classification 94V-O utilizing Flame Retardant Epoxy Molding Compound
- Exceeds environmental standards of MIL-S-19500/228.
- Ultra Fast switching for high efficiency.
- In compliance with EU RoHS 2002/95/EC directives

MECHANICAL DATA

- Case: Molded plastic, DO-15
- Terminals: Axial leads, solderable per MIL-STD-750, Method 2026
- Polarity: Band denotes cathode
- Mounting Position: Any
- Weight: 0.014 ounce, 0.397 gram

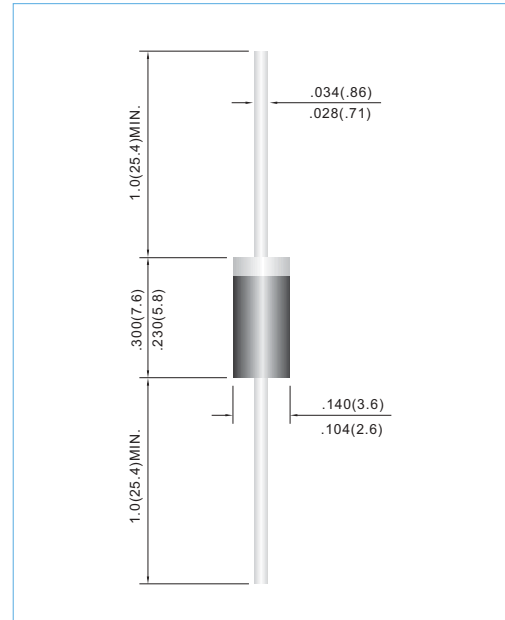

MAXIMUM RATINGS AND ELECTRICAL CHARACTERISTICS

Ratings at 25°C ambient temperature unless otherwise specified. Resistive or inductive load, 60Hz.

PARAMETER	SYMBOL	UF200	UF201	UF202	UF204	UF206	UF208	UF2010	UNITS	
Maximum Recurrent Peak Reverse Voltage	V_{RRM}	50	100	200	400	600	800	1000	V	
Maximum RMS Voltage	V_{RMS}	35	70	140	280	420	560	700	V	
Maximum DC Blocking Voltage	V_{DC}	50	100	200	400	600	800	1000	V	
Maximum Average Forward Current at $T_A=55^\circ C$	$I_{F(AV)}$	2.0							A	
Peak Forward Surge Current : 8.3ms single half sine-wave superimposed on rated load (JEDEC method)	I_{FSM}	60							A	
Maximum Forward Voltage at 2.0A	V_F	1.0		1.3		1.7			V	
Maximum DC Reverse Current at $T_J=25^\circ C$ Rated DC Blocking Voltage $T_J=100^\circ C$	I_R	10.0			500				μA	
Typical Junction capacitance (Note 1)	C_J	35							pF	
Typical Thermal Resistance (Note 2)	$R_{\theta JA}$	40							$^\circ C / W$	
Maximum Reverse Recovery Time (Note 3)	t_{rr}	50				75				ns
Operating Junction and Storage Temperature Range	T_J, T_{STG}	-55 to +150							$^\circ C$	

NOTES:

1. Measured at 1 MHz and applied reverse voltage of 4.0 VDC.
2. Thermal Resistance from Junction to Ambient and from Junction to lead length 0.375"(9.5mm) P.C.B. mounted.
3. Reverse Recovery Time $I_F=.5A, I_R=1A, I_{rr}=.25A$



UF200 ~ UF2010

RATING AND CHARACTERISTIC CURVES

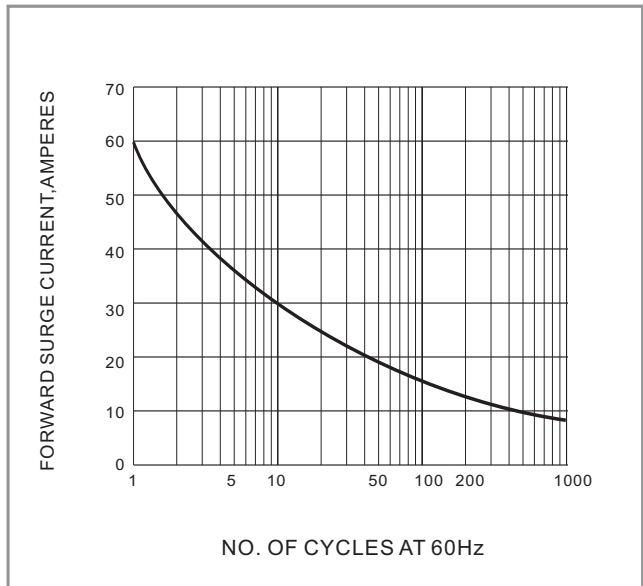
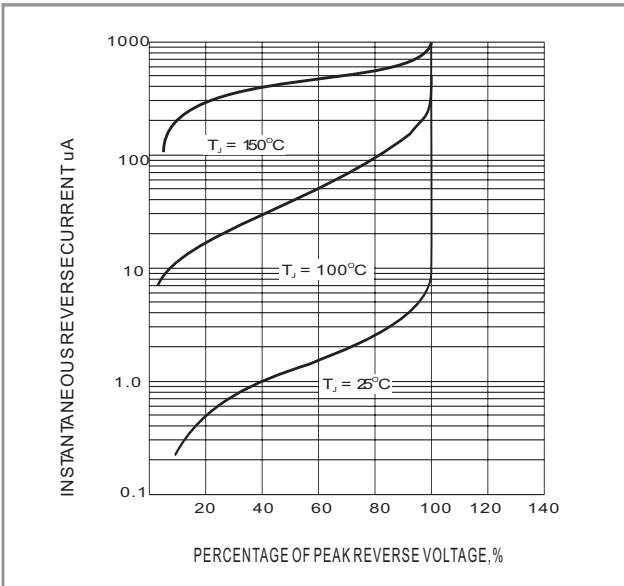
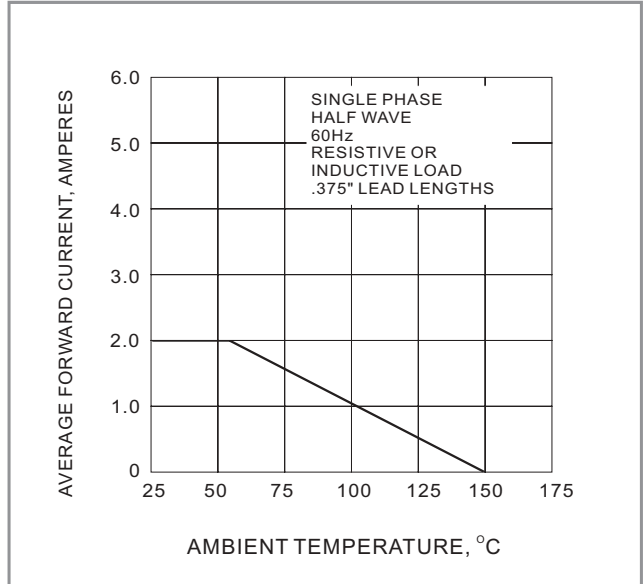
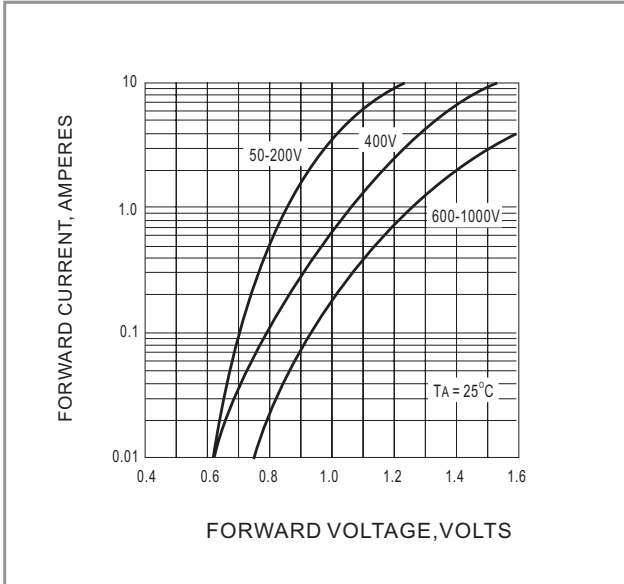



2. MARKING

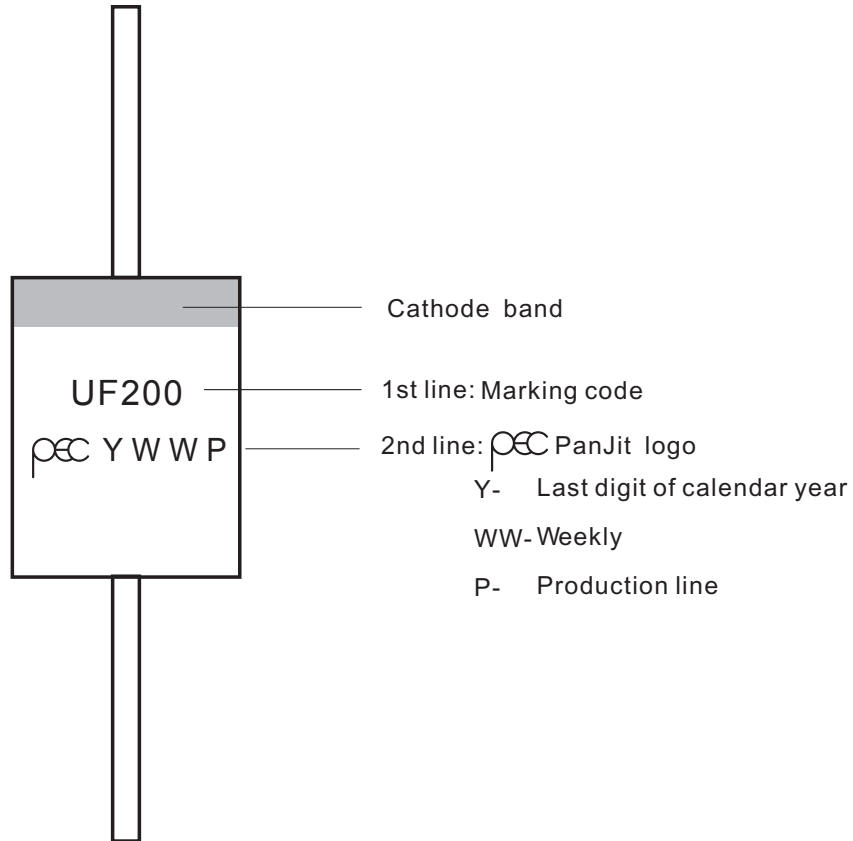



3. TAPING

Axial lead devices are packed in accordance with EIA standard RS-296-E and specifications given below.

COMPONENT OUTLINE	COMPONENT PITCH A ± 0.5mm	INTER TAPE PITCH B ± 1.0mm	CUMULATIVE PITCH TOLERANCE
DO-15	5.0mm	52.0mm	1.0mm/20pitch

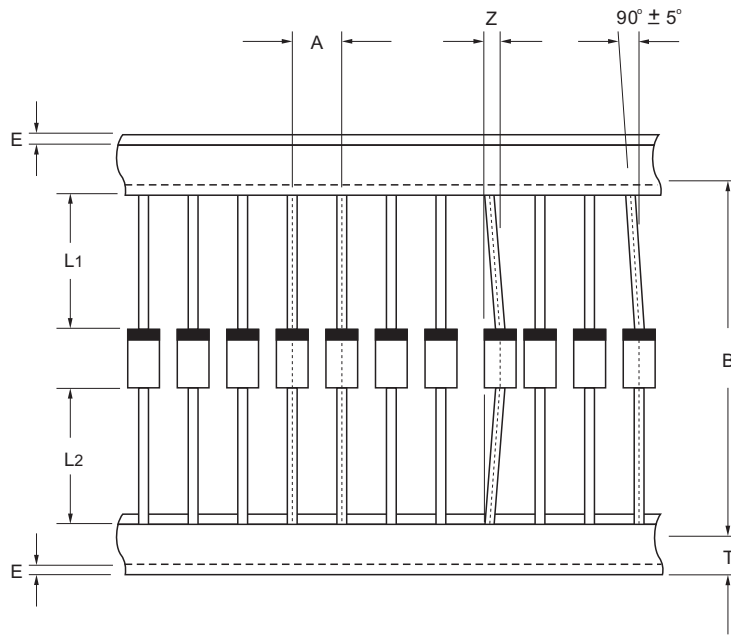

ITEM	SYMBOL	SPECIFICATIONS(mm)	SPECIFICATIONS(inch)
Component alignment	Z	1.2max	0.048max
Tape width	T	6.0±0.4	0.236±0.016
Exposed adhesive	E	0.8max	0.032max
Body eccentricity	L1-L2	1.0max	0.040max

NOTES: Each component lead shall be sandwiched between tapes for a minimum of 3.2mm (0.126")



4. PACKING

AMMUNITION PACKING

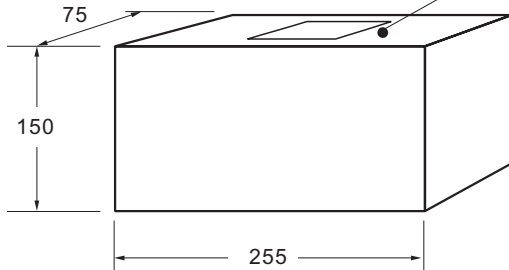

LABEL TYPE

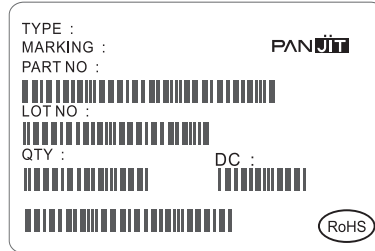

Box Dimensions : mm
Quantity per Box: 3,000 pcs

CARTON

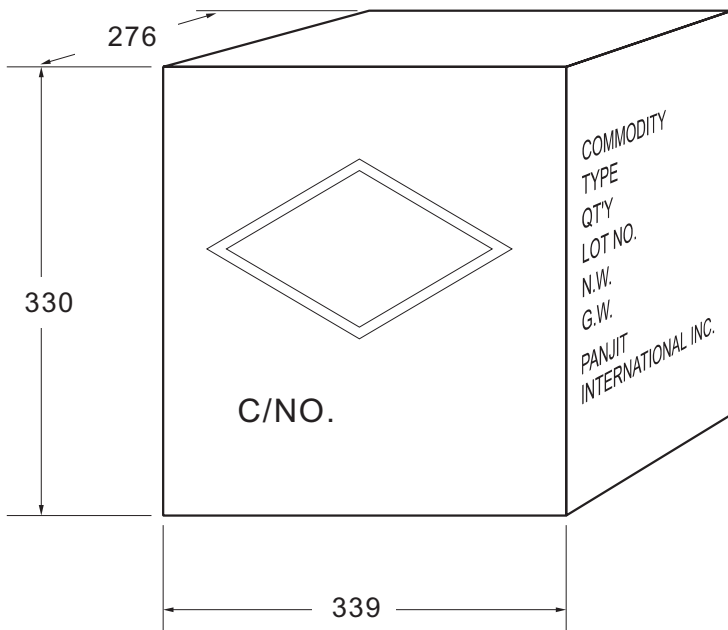

Box Dimensions : mm
Quantity per Box: 24,000 pcs

SHIPPING MARK

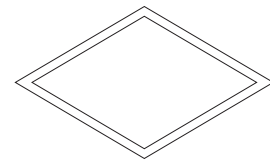

C/NO.
PRODUCT COUNTRY

SIDE MARK

COMMODITY:
TYPE:
Q'TY:
LOT NO.
N.W.
G.W.
PANJIT
INTERNATIONAL INC.



Bulk Packing

PACKAGE	INNER SIZE	BOX	CARTON SIZE	CARTON	APPROX. GROSS WEIGHT
	(m/m)	(EA)	(m/m)	(EA)	(Kg)
Bulk Packing					
A-405	198 x 84 x 20	1,000	459 x 214 x 256	50,000	12.7
AG / RB-10 (WOB)	258 x 190 x 77	1,000	395 x 270 x 400	10,000	15
AM	258 x 190 x 77	1,000	395 x 270 x 400	10,000	15
CM / KBPC	193 x 193 x 46	50	405 x 210 x 265	500	17
CMW / KBPC-W	193 x 193 x 46	50	405 x 210 x 265	500	17
KBPC-P /CP	193 x 193 x 46	50	405 x 210 x 265	500	9.5
KBPC-PW /CPW	193 x 193 x 46	50	405 x 210 x 265	500	9.5
CP-3 / 6 (K-3 / K-6)	219 x 115 x 90	200	600 x 235 x 198	2,000	7.3/8.8
CP-8 / 10 (K-8)	219 x 115 x 90	200	600 x 235 x 198	2,000	13.8
DIP	-	-	459 x 214 x 256	12,000	6.5
DO-15	200 x 85 x 25	1,000	459 x 214 x 256	40,000	20.7
DO-201AD	200 x 85 x 40	500	459 x 214 x 256	12,500	16
DO-201AE	200 x 85 x 40	500	459 x 214 x 256	12,500	16
DO-34	240 x 100 x 90	2,000	406 x 335 x 257	120,000	14.5
DO-35	240 x 100 x 90	2,000	406 x 335 x 257	120,000	17.1
DO-41	198 x 84 x 20	1,000	459 x 214 x 265	50,000	19.3
DO-41G	240 x 100 x 90	1,000	406 x 335 x 257	60,000	18.5
FL	230 x 230 x 50	500	495 x 245 x 180	3,000	18.4
GBJ (TUBE)	556 x 150 x 100	800	578 x 340 x 235	3,200	25.5
GBJ (BOX)	350 x 337 x 44	600	375 x 360 x 213	2,400	14.3
GBL	350 x 337 x 44	960	375 x 360 x 213	3,840	13.1
GBP	350 x 337 x 44	1,120	375 x 360 x 213	4,480	10.6
GBPC	193 x 193 x 46	50	405 x 210 x 265	500	17
GBPCW	193 x 193 x 46	50	405 x 210 x 265	500	17
GBU (TUBE)	488 x 150 x 100	800	510 x 310 x 235	3,200	22.6
GBU (BOX)	350 x 337 x 44	800	375 x 360 x 213	3,200	15.2
KBJ	220 x 176 x 45	200	375 x 230 x 260	2,000	15
KBPF	242 x 208 x 35	500	426 x 252 x 365	10,000	19.2
KBU	276 x 158 x 59	200	493 x 287 x 320	3,000	24
P-600	208 x 90 x 83	500	459 x 214 x 256	5,000	11.3
R-1	198 x 84 x 20	1,000	459 x 214 x 256	50,000	12.7
TO-220	540 x 145 x 85	2,000	555 x 306 x 200	8,000	20.5
ITO-220	540 x 145 x 85	2,000	555 x 306 x 200	8,000	22.9
TO-251AB	555 x 145 x 85	8,400	555 x 306 x 200	33,600	22
TO-3P / TO-247AD	-	-	536 x 243 x 100	1,500	13.9
TO-3PS / TO-247S	-	-	511 x 243 x 107	1,500	12.2



Reel Packing

PACKAGE	REEL SIZE	REEL	COMPONENT SPACE	TAPE SPACE	REEL DIA	CARTON SIZE	CARTON	APPROX. GROSS WEIGHT
	(inch)	(pcs)	(m/m)	(m/m)	(m/m)	(m/m)	(EA)	(Kg)
Reel Packing								
R-1	-	5,000	5.0	52	330	340 x 340 x 410	25,000	7.8
A-405	-	5,000	5.0	52	330	340 x 340 x 410	25,000	11
DO-15	-	4,000	5.0	52	330	340 x 340 x 410	20,000	11.4
DO-201AD	-	1,250	10.0	52	330	340 x 340 x 410	6,250	9.2
DO-201AE	-	1,250	10.0	52	330	340 x 340 x 410	6,250	9.2
DO-34	15	10,000	5.0	52	360	360 x 360 x 395	50,000	10.1
DO-35	15	10,000	5.0	52	360	360 x 360 x 395	50,000	11.2
DO-41	-	5,000	5.0	52	330	340 x 340 x 410	25,000	11.8
DO-41G	15	5,000	5.0	52	360	360 x 360 x 395	25,000	10.9
P-600	-	800	10.0	52	330	340 x 340 x 410	4,000	9.8
DPAK/TO-252	13	3,000	8.0	16	330	375 x 360 x 390	42,000	18.8
D2PAK/TO-263	13	800	16.0	24	330	375 x 360 x 390	6,400	14.4
MDI	13	3,000	8.0	12	330	375 x 360 x 390	48,000	14.7
SDIP	13	1,500	12.0	16	330	375 x 360 x 390	21,000	14.3
QUADRO-MELF	13	10,000	4.0	-	330	360 x 360 x 395	200,000	14.9
QUADRO-MELF	7	2,500	4.0	-	178	385 x 380 x 260	200,000	13.3
MELF/DL-41	13	5,000	4.0	-	330	360 x 360 x 395	100,000	23.5
MELF/DL-41	7	1,500	4.0	-	178	385 x 380 x 260	84,000	18.3
MICRO-MELF	13	10,000	4.0	-	330	360 x 360 x 395	200,000	11.5
MICRO-MELF	7	2,500	4.0	-	178	385 x 380 x 260	200,000	9.3
MINI-MELF	13	10,000	4.0	-	330	360 x 360 x 395	200,000	14.6
MINI-MELF	7	2500	4.0	-	178	385 x 380 x 260	200,000	12.7
SMA	13	7,500	4.0	12	330	375 x 360 x 390	120,000	17.3
SMA	7	1,800	4.0	12	178	390 x 240 x 420	72,000	10
SMB	13	3,000	8.0	12	330	375 x 360 x 390	48,000	13.2
SMB	7	500	8.0	12	178	390 x 240 x 420	20,000	6.5
SMC	13	3,000	8.0	16	330	375 x 360 x 390	42,000	18
SMC	7	500	8.0	16	178	390 x 240 x 420	15,000	8.3
SOD-123	13	10,000	4.0	8	330	375 x 360 x 213	120,000	6.5
SOD-123	7	3,000	4.0	8	178	390 x 270 x 400	240,000	9.9
SOD-123FL	13	10,000	4.0	8	330	375 x 360 x 213	120,000	7.2
SOD-123FL	7	3,000	4.0	8	178	390 x 270 x 400	240,000	10.6



Reel Packing

PACKAGE	REEL SIZE	REEL	COMPONENT SPACE	TAPE SPACE	REEL DIA	CARTON SIZE	CARTON	APPROX. GROSS WEIGHT
	(inch)	(pcs)	(m/m)	(m/m)	(m/m)	(m/m)	(EA)	(Kg)
Reel Packing								
SOD-323	13	12,000	4.0	8	330	375 x 360 x 213	144,000	5.9
SOD-323	7	5,000	4.0	8	178	390 x 270 x 400	400,000	9.4
SOD-523	13	12,000	4.0	8	330	375 x 360 x 213	144,000	5.4
SOD-523	7	5,000	4.0	8	178	390 x 270 x 400	400,000	9.1
SOD-723	7	8,000	2.0	8	178	390 x 270 x 400	640,000	8.5
SOD-923	7	8,000	2.0	8	178	390 x 270 x 400	640,000	7.7
SOT-23	13	12,000	4.0	8	330	375 x 360 x 213	144,000	7
SOT-23	7	3,000	4.0	8	178	390 x 270 x 400	240,000	8.3
SOT-323	13	12,000	4.0	8	330	375 x 360 x 213	144,000	6.1
SOT-323	7	3,000	4.0	8	178	390 x 270 x 400	240,000	7.9
SOT-363	13	10,000	4.0	8	330	375 x 360 x 213	120,000	7.1
SOT-363	7	3,000	4.0	8	178	390 x 270 x 400	240,000	10.2
SOT-23 (ESD)	7	3,000	4.0	8	178	455 x 270 x 440	240,000	9.5
SOT-323 (ESD)	7	3,000	4.0	8	178	455 x 270 x 440	240,000	9.1
SOT-363 (ESD)	7	3,000	4.0	8	178	455 x 270 x 440	240,000	10
SOT-353	13	10,000	4.0	8	330	375 x 360 x 213	120,000	7.2
SOT-353	7	3,000	4.0	8	178	390 x 270 x 400	240,000	10
SOT-553	13	10,000	4.0	8	330	375 x 360 x 213	120,000	5.2
SOT-553	7	4,000	4.0	8	178	390 x 270 x 400	320,000	9.4
SOT-563	13	10,000	4.0	8	330	375 x 360 x 213	120,000	5.2
SOT-563	7	4,000	4.0	8	178	390 x 270 x 400	320,000	9.4
SOT23-5L	13	10,000	4.0	8	330	375 x 360 x 213	120,000	7.9
SOT23-5L	7	3,000	4.0	8	178	390 x 270 x 400	240,000	14.5
SOT23-6L	13	10,000	4.0	8	330	375 x 360 x 213	120,000	7.9
SOT23-6L	7	3,000	4.0	8	178	390 x 270 x 400	240,000	14.5
SOT-143	13	10,000	4.0	8	330	375 x 360 x 213	120,000	7
SOT-143	7	3,000	4.0	8	178	390 x 270 x 400	240,000	12.8
SOIC-08	13	3,000	8.0	12	330	375 x 360 x 213	48,000	14.2
QFN 1.2 x 1.5	7	3,000	4.0	8	178	390 x 270 x 400	240,000	7.1
QFN 1.6 x 1.6	7	4,000	4.0	8	178	390 x 240 x 420	200,000	7.8
QFN 2.0 x 2.0	7	3,000	4.0	8	178	390 x 270 x 400	240,000	7.1



Ammunition Packing

PACKAGE	AMMO	COMPONENT SPACE	TAPE SPACE	BOX SIZE	CARTON	CARTON	APPROX. GROSS WEIGHT
	(PCS)	(m/m)	(m/m)	(m/m)	(m/m)	(E/A)	(Kg)
Ammunition Packing							
A-405	5,000	5	26	255 x 47 x 150	339 x 276 x 330	60,000	12.4
A-405	5,000	5	52	255 x 75 x 150	339 x 276 x 330	40,000	16
DO-15	3,000	5	52	255 x 75 x 150	339 x 276 x 330	24,000	13.3
DO-201AD	1,250	10	52	255 x 47 x 122	339 x 276 x 330	10,000	13.4
DO-201AE	1,250	10	52	255 x 47 x 122	339 x 276 x 330	10,000	13.4
DO-34	5,000	5	26	248 x 80 x 48	406 x 335 x 257	150,000	14.6
DO-34	5,000	5	52	248 x 80 x 75	406 x 335 x 257	100,000	12.7
DO-35	5,000	5	26	248 x 80 x 48	406 x 335 x 257	150,000	16.7
DO-35	5,000	5	52	248 x 80 x 75	406 x 335 x 257	100,000	15.2
DO-41	5,000	5	52	255 x 75 x 150	339 x 276 x 330	40,000	16
DO-41G	2,500	5	26	248 x 80 x 48	406 x 335 x 257	75,000	17.1
DO-41G	2,500	5	52	248 x 80 x 75	406 x 335 x 257	50,000	15.7
P-600	400	10	52	255 x 47 x 122	339 x 276 x 330	3,200	8.1
R-1	3,000	5	26	255 x 47 x 73	310 x 268 x 170	36,000	6.3
R-1	3,000	5	52	256 x 73 x 73	310 x 268 x 170	24,000	6.4
R-1	5,000	5	52	255 x 73 x 122	339 x 276 x 274	40,000	10.3



5. HIGH RELIABILITY TESTING SPEC.

NO	TEST ITEM	TEST CONDITION	REFERENCE DOCUMENT	LOT QUALITY LEVEL	REMARK
1	TEMPERATURE CYCLING (T.C.T)	Ta = -55 + 0, -3 °C 10min Ta = + 150 +/- °C 10min FOR 20 CYCLE	MIL-STD-750D METHOD-1051.5	LTPD 10 S.s. = 22 ACCEPT FOR 0 FAILURE ONLY.	
2	HIGH TEMPERATURE STORAGE LIFE (H.T.S.L)	Ta = 150 +/- 5 °C TESTING TIME: 168 HRS 500 HRS	MIL-STD-750D METHOD-1031.2	LTPD10 S.s. = 22 ACCEPT FOR 0 FAILURE ONLY.	
3	SOLDERABILITY TEST	TEMPERATURE OF SOLDER POT = 245 +/- 5 °C TIME FOR DIPPING FLUX = 5 -10 SEC TIME FOR DIPPING IN SOLDER = 5 +/- 0.5 SEC DIPPING DEPTH = 0.05 inch max FOR ONE CYCLE	MIL-STD-750D	METHOD-2026.10 LTPD 7 S.s. = 32 ACCEPT FOR 0 FAILURE ONLY.	
4	HIGH TEMPERATURE REVERSE BIAS (H.T.R.B)	Ta = 150 +/- 5 °C VR = 80 % VR (CUSTOM SECP) TESTING TIME: 168 HRS 500 HRS	MIL-STD-750D METHOD-1038.3	LTPD10 S.s. = 22 ACCEPT FOR 0 FAILURE ONLY.	
5	CONTINUE FORWARD OPERATING LIFE (C.F.O.L)	Ta = 55 °C I = IO +/- 10 % TESTING TIME: 168 HRS 500 HRS	MIL-STD-750D METHOD-1027.3	LTPD10 S.s. = 22 ACCEPT FOR 0 FAILURE ONLY.	
6	THERMAL SHOCK (T.S.T)	HOT TANK T = 100 °C + 10 / -2 °C t = 5 min COLD TANK T = 0 °C + 2 / -10 °C t = 5 min 15 CYCLE TIME BETWEEN TRANSFERRING DO'NOT EXCEED 10 SECOND.	MIL-STD-750D METHOD-1056.7	LTPD10 S.s. = 22 ACCEPT FOR 0 FAILURE ONLY.	
7	PRESSURE COOKER (P.C.T)	Ta = 121 °C P = 1.2 kg / cm ² TIME = 96 HRS	JEDEC JESD22-A102-C	LTPD10 S.s. = 22 ACCEPT FOR 0 FAILURE ONLY.	
8	INTERMITTENT FORWARD OPERATING LIFE (I.F.O.L)	I = Io x 1.0 POWER ON : 30 SEC POWER OFF : 50 SEC TESTING TIME: 2000 CYCLES	MIL-STD-750D METHOD 1036.3	LTPD10 S.s. = 22 ACCEPT FOR 0 FAILURE ONLY.	
9	FORWARD SURGE CURRENT (I.F.S.M)	SQ WAVE OR SINE WAVE IFSM=DATE SHEET SPEC. TIME = 8.3 Msec T = 1 CYCLE	MIL-STD-750D METHOD 4066.3	LTPD10 S.s. = 22 ACCEPT FOR 0 FAILURE ONLY.	
10	HUMIDITY	Ta = 85 °C RH = 85 % TESTING TIME: 168 HRS 500 HRS	MIL-STD-750D METHOD 1021.1	LTPD10 S.s. = 22 ACCEPT FOR 0 FAILURE ONLY.	
11	SOLDERABILITY RESISTANCE	TEMPERATURE OF SOLDER POT = 260 +/- 5 °C TIME FOR DIPPING IN SOLDER = 10 + 2 / -0 SEC DIPPING DEPTH = 1.57 +/- 0.79 mm BELOW BODY FOR ONE CYCLE	MIL-STD-750D METHOD 2031.1	LTPD10 S.s. = 22 ACCEPT FOR 0 FAILURE ONLY.	

SCHOTTKY PRODUCT TESTING TEMPERATURE 100 °C +/- 5°C MAX(NORMAL)