



TABLE OF CONTENTS

1.DATA SHEET PAGE 1

2.MARKING PAGE 6

3.TAPING PAGE 7

4.PACKING PAGE8

5.HIGH RELIABILITY TEST SPEC PAGE12



BZX84B2V4 SERIES

SURFACE MOUNT SILICON ZENER DIODES

VOLTAGE 2.4 to 75 Volts **POWER** 410 mWatts

SOT-23

Unit: inch (mm)

FEATURES

- Planar Die construction
- 410mW Power Dissipation
- Zener Voltages from 2.4~75V
- Ideally Suited for Automated Assembly Processes
- In compliance with EU RoHS 2002/95/EC directives

MECHANICAL DATA

- Case: SOT-23, Molded Plastic
- Terminals: Solderable per MIL-STD-750, Method 2026
- Polarity: See Diagram Below
- Approx. Weight: 0.008 grams
- Mounting Position: Any

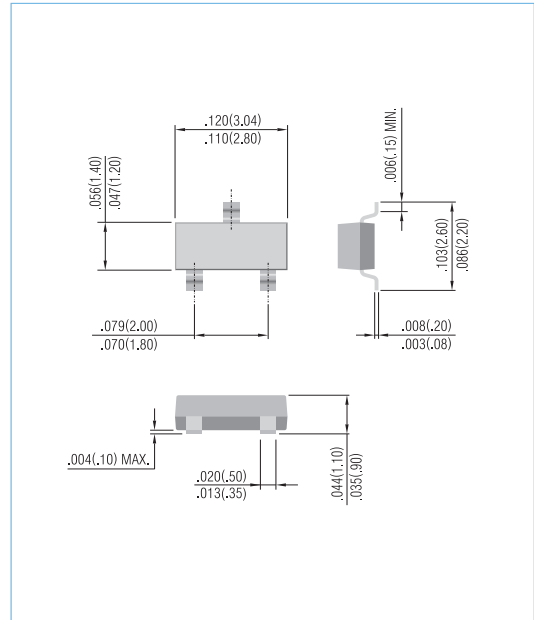

MAXIMUM RATINGS AND ELECTRICAL CHARACTERISTICS

Parameter	Symbol	Value	Units
Maximum Power Dissipation (Notes A) at 25°C	P _D	410	mW
Operating Junction and Storage Temperature Range	T _J	-55 to +150	°C

NOTES:

A. Mounted on 5.0mm²(.013mm thick) land areas.



BZX84B2V4 SERIES

Part Number	Nominal Zener Voltage			Max. Zener Impedance				Max Reverse Leakage Current		Marking Code
	V _Z @ I _{ZT}			Z _{ZT} @ I _{ZT}		Z _{ZK} @ I _{ZK}		I _R @ V _R		
	Nom. V	Min. V	Max. V	Ω	mA	Ω	mA	μA	V	
410 mWatts Zener Diodes										
BZX84B2V4	2.4	2.35	2.45	100	5.0	600	1.00	50	1.0	W1
BZX84B2V7	2.7	2.64	2.75	100	5.0	600	1.00	20	1.0	W2
BZX84B3	3.0	2.94	3.06	95	5.0	600	1.00	10	1.0	W3
BZX84B3V3	3.3	3.23	3.37	95	5.0	600	1.00	5.0	1.0	W4
BZX84B3V6	3.6	3.52	3.67	90	5.0	600	1.00	5.0	1.0	W5
BZX84B3V9	3.9	3.82	3.98	90	5.0	600	1.00	3.0	1.0	W6
BZX84B4V3	4.3	4.21	4.39	90	5.0	600	1.00	3.0	1.0	W7
BZX84B4V7	4.7	4.61	4.79	80	5.0	500	1.00	3.0	2.0	W8
BZX84B5V1	5.1	5.00	5.20	60	5.0	480	1.00	2.0	2.0	W9
BZX84B5V6	5.6	5.49	5.71	40	5.0	400	1.00	1.0	2.0	WA
BZX84B6V2	6.2	6.08	6.32	10	5.0	150	1.00	3.0	4.0	WB
BZX84B6V8	6.8	6.66	6.94	15	5.0	80	1.00	2.0	4.0	WC
BZX84B7V5	7.5	7.35	7.65	15	5.0	80	1.00	1.0	5.0	WD
BZX84B8V2	8.2	8.04	8.36	15	5.0	80	1.00	0.7	5.0	WE
BZX84B8V7	8.7	8.53	8.87	15	5.0	100	1.00	0.7	5.0	87C
BZX84B9V1	9.1	8.92	9.28	15	5.0	100	1.00	0.5	6.0	WF
BZX84B10	10	9.80	10.20	20	5.0	150	1.00	0.2	7.0	WG
BZX84B11	11	10.78	11.22	20	5.0	150	1.00	0.1	8.0	WH
BZX84B12	12	11.76	12.24	25	5.0	150	1.00	0.1	8.0	WI
BZX84B13	13	12.74	13.26	30	5.0	170	1.00	0.1	8.0	WK
BZX84B14	14	13.72	14.28	30	5.0	170	1.00	0.1	10.0	WJ
BZX84B15	15	14.70	15.30	30	5.0	200	1.00	0.1	10.5	WL
BZX84B16	16	15.68	16.32	40	5.0	200	1.00	0.1	11.2	WM
BZX84B17	17	16.66	17.34	40	5.0	200	1.00	0.1	12.2	17C
BZX84B18	18	17.64	18.36	45	5.0	225	1.00	0.1	12.6	WN
BZX84B20	20	19.60	20.40	55	5.0	225	1.00	0.1	14.0	WO
BZX84B22	22	21.56	22.44	55	5.0	250	1.00	0.1	15.4	WP
BZX84B24	24	23.52	24.48	70	5.0	250	1.00	0.1	16.8	WR
BZX84B27	27	26.46	27.54	80	5.0	300	1.00	0.1	18.9	WS
BZX84B28	28	27.44	28.56	80	5.0	300	1.00	0.1	20.5	28C
BZX84B30	30	29.40	30.60	80	5.0	300	1.00	0.1	21.0	WT
BZX84B33	33	32.34	33.66	80	5.0	325	1.00	0.1	23.1	WU
BZX84B36	36	35.28	36.72	90	5.0	350	1.00	0.1	25.2	WW
BZX84B39	39	38.22	39.78	130	5.0	350	1.00	0.1	27.3	WX
BZX84B43	43	42.14	43.86	150	5.0	375	1.00	0.1	30.1	WY
BZX84B47	47	46.06	47.94	170	5.0	375	1.00	0.1	32.9	WZ
BZX84B51	51	49.98	52.02	100	5.0	400	1.00	0.1	38.0	XA
BZX84B56	56	54.88	57.12	135	2.5	1000	1.00	0.1	42.0	X2
BZX84B62	62	60.76	63.24	150	2.5	1000	1.00	0.1	46.0	X3
BZX84B68	68	66.64	69.36	200	2.5	1000	1.00	0.1	51.0	X4
BZX84B75	75	73.50	76.50	250	2.5	1000	1.00	0.1	56.0	X5



BZX84B2V4 SERIES

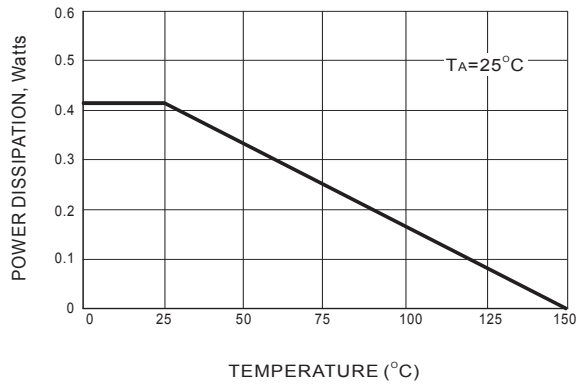

Fig. 1 STEADY STATE POWER DERATING

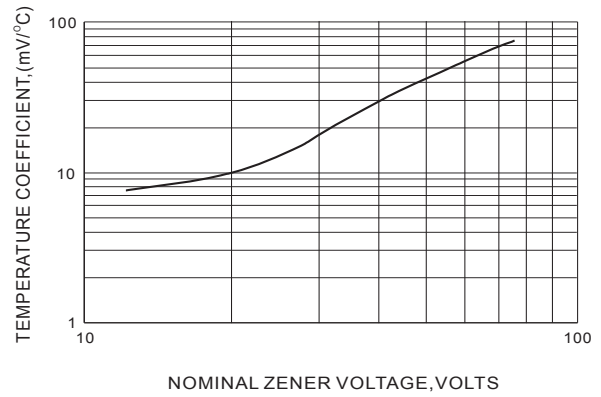

Fig. 2 TEMPERATURE COEFFICIENTS

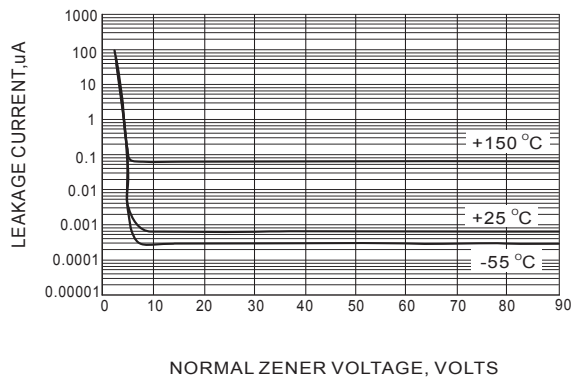

Fig. 3 TYPICAL LEAKAGE CURRENT

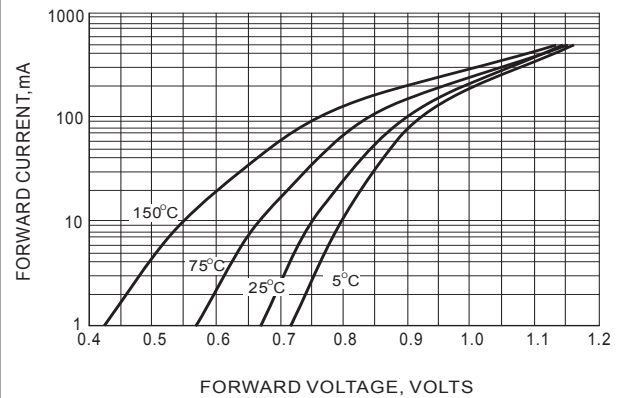
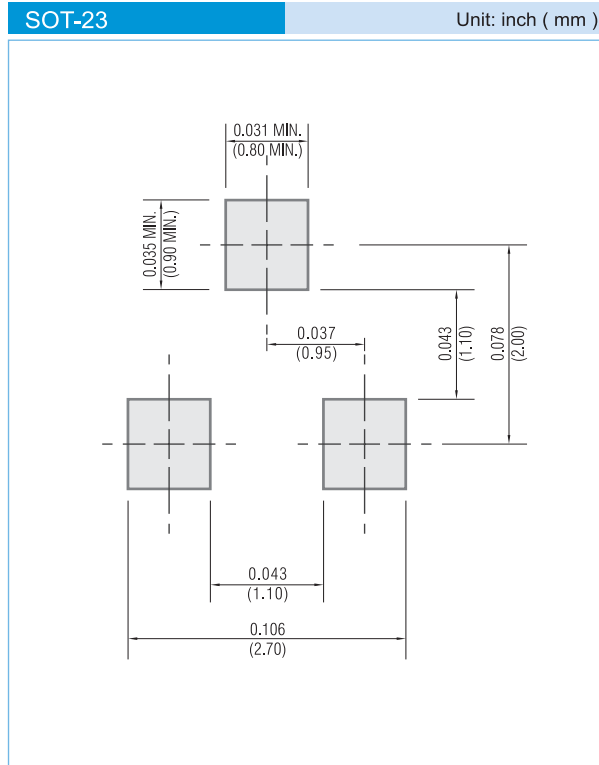

Fig. 4 TYPICAL FORWARD VOLTAGE



BZX84B2V4 SERIES

MOUNTING PAD LAYOUT



ORDER INFORMATION

- Packing information
 - T/R - 12K per 13" plastic Reel
 - T/R - 3K per 7" plastic Reel

LEGAL STATEMENT

Copyright PanJit International, Inc 2011

The information presented in this document is believed to be accurate and reliable. The specifications and information herein are subject to change without notice. Pan Jit makes no warranty, representation or guarantee regarding the suitability of its products for any particular purpose. Pan Jit products are not authorized for use in life support devices or systems. Pan Jit does not convey any license under its patent rights or rights of others.



2. MARKING

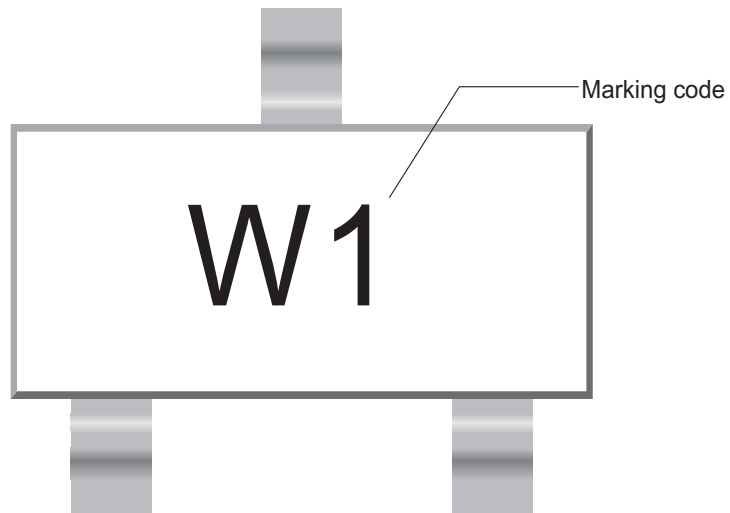



3. TAPING

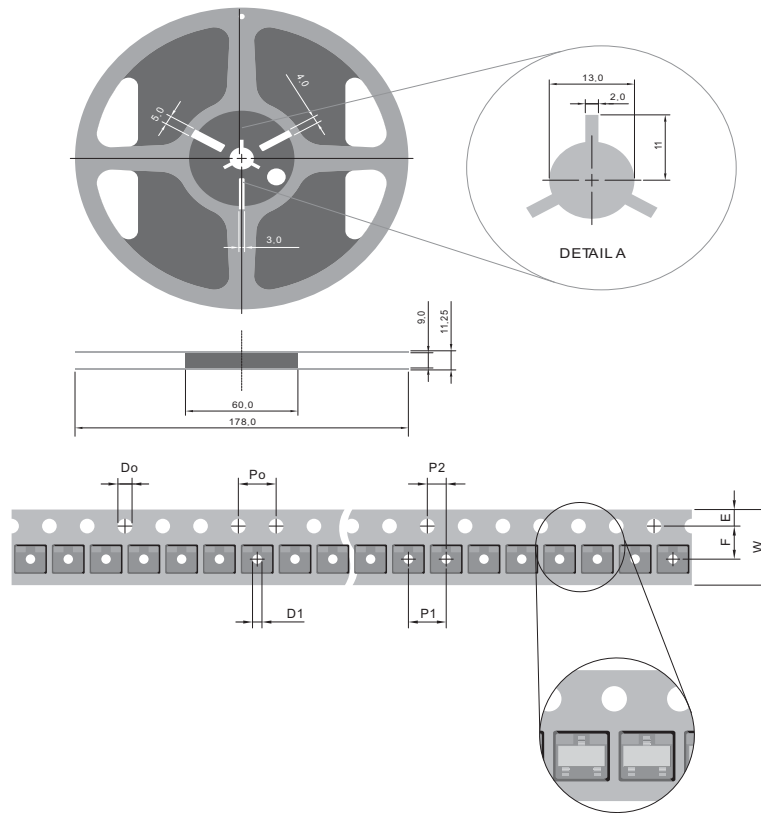

SYMBOL	mm (inch)
TYPE SIZE	8.00 (0.314)
D0	1.50 ± 0.10(0.059 ± 0.004)
D1	1.00 ± 0.25(0.039 ± 0.010)
E	1.75 ± 0.10(0.069 ± 0.004)
F	3.50 + 0.05(0.137 ± 0.002)
Po	4.00 ± 0.10(0.157 ± 0.004)
P1	4.00 ± 0.10(0.157 ± 0.004)
P2	2.00 ± 0.05(0.009 ± 0.002)
W	8.00

NOTE:

1. There shall be leader of 230 mm minimum which may consist of carrier and or cover tape follower by a minimum of 160 mm of carrier tape sealed with cover tape.
2. There shall be minimum of 160 mm of empty component pockets sealed with cover tape.
3. Devices are packed in accordance with EIA standard EIA-481-A and specifications given above.



4. PACKING

REEL PACKING

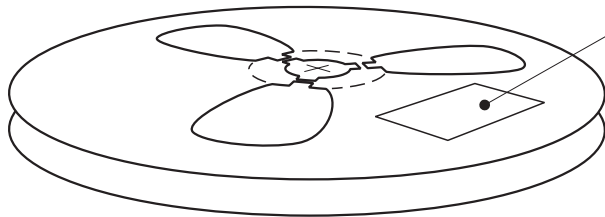

Quantity per Reel: 3,000 pcs

LABEL TYPE

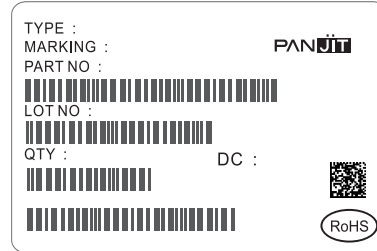

CARTON

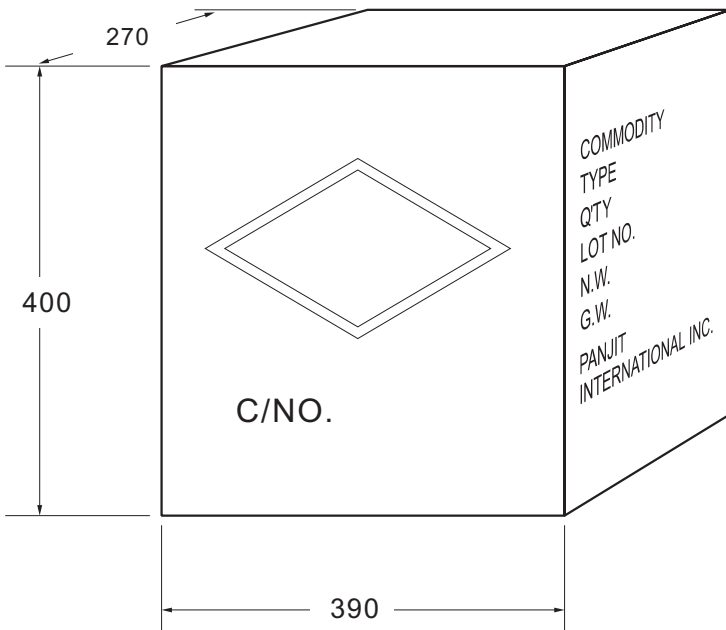

Box Dimensions : mm
Quantity per Box: 240,000pcs

SHIPPING MARK

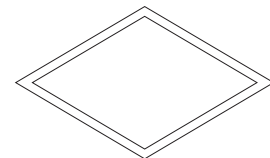

C/NO.
PRODUCT COUNTRY

SIDE MARK

COMMODITY:
TYPE:
Q'TY:
LOT NO.
N.W.
G.W.
PANJIT
INTERNATIONAL INC.



Packing Specifications

Package	Reel Size	Reel	Component Space	Tape Space	Reel Dia	Carton Size	Carton	Approx. Gross Weight
	(inch)	(pcs)	(m/m)	(m/m)	(m/m)	(m/m)	(EA)	(Kg)
Reel Packing								
DFN 2L	7	8,000	2	8	178	390 x 270 x 400	640,000	8.6
DFN 3L	7	8,000	2	8	178	390 x 270 x 400	640,000	8.6
SOD-123	7	3,000	4	8	178	390 x 270 x 400	240,000	9.9
	13	10,000	4	8	330	375 x 360 x 213	120,000	6.5
SOD-123FL	7	3,000	4	8	178	390 x 270 x 400	240,000	10.6
	13	10,000	4	8	330	375 x 360 x 213	120,000	7.2
SOD-123HE	7	3,000	4	8	178	390 x 270 x 400	240,000	12.4
	13	10,000	4	8	330	375 x 360 x 213	120,000	8.1
SOD-323	7	5,000	4	8	178	390 x 270 x 400	400,000	9.4
	13	12,000	4	8	330	375 x 360 x 213	144,000	5.9
SOD-523	7	5,000	4	8	178	390 x 270 x 400	400,000	9.1
	13	12,000	4	8	330	375 x 360 x 213	144,000	5.4
SOD-723	7	8,000	2	8	178	390 x 270 x 400	640,000	8.5
SOD-923	7	8,000	2	8	178	390 x 270 x 400	640,000	7.7
SOT-23	7	3,000	4	8	178	390 x 270 x 400	240,000	9.8
	13	12,000	4	8	330	375 x 360 x 213	144,000	7
SOT-23 (ESD)	7	3,000	4	8	178	455 x 270 x 440	240,000	9.9
SOT-23 5L	7	3,000	4	8	178	390 x 270 x 400	240,000	14.5
	13	10,000	4	8	330	375 x 360 x 213	120,000	7.9
SOT-23 6L	7	3,000	4	8	178	390 x 270 x 400	240,000	14.5
	13	10,000	4	8	330	375 x 360 x 213	120,000	7.9
SOT-323	7	3,000	4	8	178	390 x 270 x 400	240,000	7.9
	13	12,000	4	8	330	375 x 360 x 213	144,000	6.1
SOT-323 (ESD)	7	3,000	4	8	178	455 x 270 x 440	240,000	9.4
SOT-353	7	3,000	4	8	178	390 x 270 x 400	240,000	10
	13	10,000	4	8	330	375 x 360 x 213	120,000	7.2
SOT-363	7	3,000	4	8	178	390 x 270 x 400	240,000	10.2
	13	10,000	4	8	330	375 x 360 x 213	120,000	7.1
SOT-363 (ESD)	7	3,000	4	8	178	455 x 270 x 440	240,000	10
SOT-523	7	4,000	4	8	178	390 x 270 x 400	320,000	10
SOT-543	7	4,000	4	8	178	390 x 270 x 400	320,000	9.4
	13	10,000	4	8	330	375 x 360 x 213	120,000	5.2
SOT-553	7	4,000	4	8	178	390 x 270 x 400	320,000	9.4
	13	10,000	4	8	330	375 x 360 x 213	120,000	5.2
SOT-563	7	4,000	4	8	178	390 x 270 x 400	320,000	9.4
	13	10,000	4	8	330	375 x 360 x 213	120,000	5.2
SOIC-08	13	3,000	8	12	330	375 x 360 x 213	48,000	14.2



Packing Specifications

Package	Reel Size	Reel	Component Space	Tape Space	Reel Dia	Carton Size	Carton	Approx. Gross Weight
	(inch)	(pcs)	(m/m)	(m/m)	(m/m)	(m/m)	(EA)	(Kg)
Reel Packing								
A-405	-	5,000	5	52	330	340 x 340 x 410	25,000	7.79
DO-15	-	4,000	5	52	330	340 x 340 x 410	20,000	11.4
DO-201AD	-	1,250	10	52	330	340 x 340 x 410	6,250	9.2
DO-201AE	-	1,250	10	52	330	340 x 340 x 410	6,250	9.2
DO-34	15	10,000	5	52	360	360 x 360 x 395	50,000	10.1
DO-35	15	10,000	5	52	360	360 x 360 x 395	50,000	11.2
DO-41	-	5,000	5	52	330	340 x 340 x 410	25,000	10.2
DO-41G	15	5,000	5	52	360	360 x 360 x 395	25,000	10.9
MDI	13	3,000	8	12	330	375 x 360 x 390	48,000	14.7
MELF/DL-41	7	1,500	4	-	178	385 x 380 x 260	84,000	18.3
	13	5,000	4	-	330	360 x 360 x 395	100,000	23.5
MICRO-MELF	7	2,500	4	-	178	385 x 380 x 260	200,000	9.3
	13	10,000	4	-	330	360 x 360 x 395	200,000	11.5
MINI-MELF/LL-34	7	2500	4	-	178	385 x 380 x 260	200,000	12.7
	13	10,000	4	-	330	360 x 360 x 395	200,000	14.6
MICRO DIP/TDI	7	1000	8	12	178	390 x 240 x 420	40,000	9.5
	13	4000	8	12	330	375 x 360 x 390	64,000	17
P-600	-	800	10	52	330	340 x 340 x 410	4,000	9.9
QUADRO-MELF	13	10,000	4	-	330	360 x 360 x 395	200,000	14.9
	7	2,500	4	-	178	385 x 380 x 260	200,000	13.3
R-1	-	5,000	5	52	330	340 x 340 x 410	25,000	7.8
SDIP	13	1,500	12	16	330	375 x 360 x 390	21,000	14.3
SMA(W)	7	1,800	4	12	178	390 x 240 x 420	100,800	13
	13	7,500	4	12	330	355 x 355 x 400	150,000	20.4
SMA/DO-214AC	7	1,800	4	12	178	390 x 240 x 420	72,000	10
	13	7,500	4	12	330	375 x 360 x 390	120,000	17.4
SMB/DO-214AA	7	500	8	12	178	390 x 240 x 420	20,000	6.5
	13	3,000	8	12	330	375 x 360 x 390	48,000	13.2
SMC/DO-214AB	7	500	8	16	178	390 x 240 x 420	15,000	8.4
	13	3,000	8	16	330	375 x 360 x 390	42,000	18
TO-252/DPAK	13	3,000	8	16	330	375 x 360 x 390	42,000	18.8
TO-263/D ² PAK	13	800	16	24	330	375 x 360 x 390	6,400	14.5



Packing Specifications

Package	Inner Box Size	Box	Carton Size	Carton	Approx. Gross Weight
	(m/m)	(EA)	(m/m)	(EA)	(Kg)
Bulk Packing					
A-405	198 x 84 x 20	1,000	459 x 214 x 256	50,000	12.7
DO-15	200 x 85 x 25	1,000	459 x 214 x 256	40,000	20.7
DO-201AD	200 x 85 x 40	500	459 x 214 x 256	12,500	16
DO-201AE	200 x 85 x 40	500	495 x 214 x 256	12,500	16
DO-34	240 x 100 x 90	2,000	406 x 335 x 257	120,000	14.5
DO-35	240 x 100 x 90	2,000	406 x 335 x 257	120,000	17.1
DO-41	198 x 84 x 20	1,000	459 x 214 x 256	50,000	19.3
DO-41G	240 x 100 x 90	1,000	406 x 335 x 257	60,000	18.5
DIP	-	-	459 x 214 x 256	12,000	6.5
SDIP	-	-	459 x 214 x 256	24,000	15.7
R-1	198 x 84 x 20	1,000	459 x 214 x 256	50,000	12.7
P-600	208 x 90 x 83	500	459 x 214 x 256	5,000	11.3
ITO-220	540 x 145 x 85	2,000	555 x 306 x 200	8,000	20.5
TO-220	540 x 145 x 85	2,000	555 x 306 x 200	8,000	22.9
TO-251AB/DPAK	540 x 145 x 85	8,400	555 x 306 x 200	33,600	22
TO-3P/TO-247AD	-	-	530 x 243 x 100	1,500	13.9
TO-3PS/TO-247S	-	-	511 x 243 x 107	1,500	12.2

Package	Ammo	Component Space	Tape Space	Inner Box Size	Carton Size	Carton	Approx. Gross Weight
	(pcs)	(m/m)	(m/m)	(m/m)	(m/m)	(EA)	(Kg)
Ammunition Packing							
A-405	5,000	5	26	255 x 47 x 150	339 x 276 x 330	60,000	12.4
A-405	5,000	5	52	255 x 75 x 150	339 x 276 x 330	40,000	16
DO-15	3,000	5	52	255 x 75 x 150	339 x 276 x 330	24,000	13.3
DO-201AD	1,250	10	52	255 x 47 x 122	339 x 276 x 330	10,000	13.4
DO-201AE	1,250	10	52	255 x 47 x 122	339 x 276 x 330	10,000	13.4
DO-34	5,000	5	26	248 x 80 x 48	406 x 335 x 257	150,000	14.5
DO-34	5,000	5	52	248 x 80 x 75	406 x 335 x 257	100,000	12.7
DO-35	5,000	5	26	248 x 80 x 48	406 x 335 x 257	150,000	16.7
DO-35	5,000	5	52	248 x 80 x 75	406 x 335 x 257	100,000	15.2
DO-41	5,000	5	52	255 x 75 x 150	339 x 276 x 330	40,000	13.5
DO-41G	2,500	5	26	248 x 80 x 48	406 x 335 x 257	75,000	17.1
DO-41G	2,500	5	52	248 x 80 x 75	406 x 335 x 257	50,000	15.6
P-600	400	10	52	255 x 47 x 122	339 x 276 x 330	3,200	8.1
R-1	3,000	5	26	255 x 47 x 73	310 x 268 x 170	36,000	6.3
R-1	3,000	5	52	255 x 73 x 73	310 x 268 x 170	24,000	6.2
R-1	5,000	5	52	255 x 73 x 122	339 x 276 x 274	40,000	10.1

5.HIGH RELIABILITY TEST SPEC (Zener & TVS)

Date : 2010.07.05 rev.01

NO.	TEST ITEM	TEST CONDITION	REFERENCED DOCUMENT	LOT QUALITY LEVEL
1	TEMPERATURE CYCLING (T.C.T) 溫度循環試驗	Ta = -55+0°C / -10°C 10min(Min) Ta = +150+15°C / -0°C 10min(Min) FOR 20CYCLES	MIL-STD-750D METHOD-1051.5 Condition G	LTPD 10 S.S =22 ACCEPT FOR 0 FAILURE ONLY.
2	HIGH TEMPERATURE STORAGE LIFE (H.T.S.L) 高溫儲存壽命試驗	Ta = Storage Temperature Range (device specified maximum temperature)	MIL-STD-750D METHOD-1032.2	LTPD 10 S.S =22 ACCEPT FOR 0 FAILURE ONLY.
3	SOLDERABILITY TEST 錫錫性試驗	Temperature of Solder TEMPERATURE OF SOLDER POT = 245 +/- 5°C TIME FOR DIPPING IN SOLDER = 5 +/- 0.5 SEC DIPPING DEPTH = 0.05inch max from the body FOR ONE CYCLE	MIL-STD-750D METHOD-2026.10	LTPD 7 S.S =32 ACCEPT FOR 0 FAILURE ONLY.
4	HIGH TEMPERATURE REVERSE BIAS (H.T.R.B) 高溫逆向偏壓	Tj ≤ Tj max VR = 0.8VR (CUSTOMER SPEC.) DC supply	MIL-STD-750D METHOD-1038.3	LTPD 10 S.S =22 ACCEPT FOR 0 FAILURE ONLY.
6	THERMAL SHOCK (T.S.T) 冷熱衝擊試驗	HOT TANK Ta = 100 + 10 / - 2°C t = 5min COLD TANK Ta = 0 + 2 / - 10°C t = 5min 15 CYCLES TIME BETWEEN TRANSFERRING DO NOT EXCEED 10 SEC	MIL-STD-750D METHOD 1056.7	LTPD 10 S.S =22 ACCEPT FOR 0 FAILURE ONLY.
7	PRESSURE COOKER (P.C.T) 壓力鍋試驗	Ta = 121°C P = 29.7psia / 205kPa or 2.088kg/cm ² Relative Humidity = 100%	JEDEC JESD22-A102-C	LTPD 10 S.S =22 ACCEPT FOR 0 FAILURE ONLY.
8	HUMIDITY 恆溫濕試驗	Ta = 85 +/- 2°C RH = 85 +/- 5%	EIAJ ED-4701 METHOD 103	LTPD 10 S.S =22 ACCEPT FOR 0 FAILURE ONLY.
9	SOLDER RESISTANCE 錫錫耐熱性試驗	TEMPERATURE OF SOLDER POT = 260 +/- 5°C TIME FOR DIPPING IN SOLDER = 10 + 2 / - 0 SEC DIPPING DEPTH = 1.57 +/- 0.79mm FROM THE BODY FOR ONE CYCLE	MIL-STD-750D METHOD 2031.2	LTPD 10 S.S =22 ACCEPT FOR 0 FAILURE ONLY.