



TABLE OF CONTENTS

1.DATA SHEET

PAGE 1

2.MARKING

PAGE 4

3.TAPING

PAGE 5

4.PACKING

PAGE 6

5.HIGH RELIABILITY TEST SPEC.

PAGE 10



1.DATA SHEET

FR2A~FR2M

SURFACE MOUNT FAST RECOVERY RECTIFIER

VOLTAGE 50 to 1000 Volts **CURRENT** 2.0 Ampere

SMB/DO-214AA

Unit: inch (mm)

FEATURES

- For surface mounted applications
- Low profile package
- Built-in strain relief
- Easy pick and place
- Fast Recovery times for high efficiency
- Plastic package has Underwriters Laboratory Flammability Classification 94V-0
- Glass passivated junction
- In compliance with EU RoHS 2002/95/EC directives

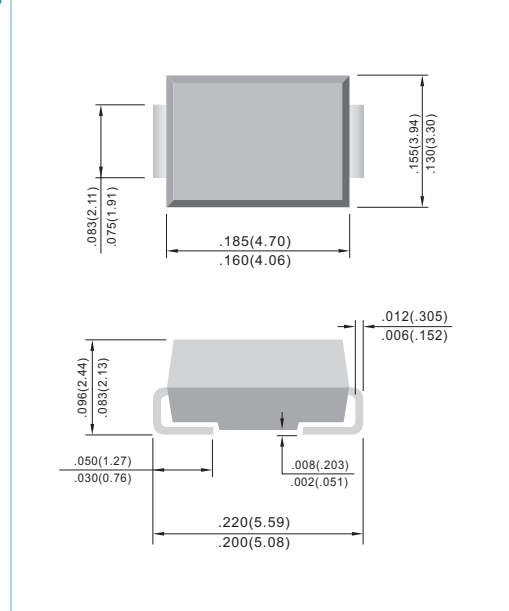

MECHANICAL DATA

Case: JEDEC DO-214AA molded plastic
 Terminals: Solder plated, solderable per MIL-STD-750, Method 2026
 Polarity: Indicated by cathode band
 Standard packaging: 12mm tape (EIA-481)
 Weight: 0.003 ounce, 0.093 gram

MAXIMUM RATINGS AND ELECTRICAL CHARACTERISTICS

Ratings at 25°C ambient temperature unless otherwise specified. Single phase, half wave, 60 Hz, resistive or inductive load.
 For capacitive load, derate current by 20%.

PARAMETER	SYMBOL	FR2A	FR2B	FR2D	FR2G	FR2J	FR2K	FR2M	UNITS
Maximum Recurrent Peak Reverse Voltage	V_{RRM}	50	100	200	400	600	800	1000	V
Maximum RMS Voltage	V_{RMS}	35	70	140	280	420	560	700	V
Maximum DC Blocking Voltage	V_{DC}	50	100	200	400	600	800	1000	V
Maximum Average Rectified Current at $T_L=90^\circ\text{C}$	I_o	2.0							A
Peak Forward Surge Current :8.3ms single half sine-wave superimposed on rated load(JEDEC method)	I_{FSM}	50							A
Maximum Forward Voltage at 2.0A	V_F	1.3							V
Maximum DC Reverse Current $T_A=25^\circ\text{C}$ at Rated DC Blocking Voltage $T_A=125^\circ\text{C}$	I_R	5.0 150							μA
Maximum Reverse Recovery Time (Note 1)	T_{RR}	150				250		500	ns
Maximum Junction capacitance (Note 2)	C_J	40							pF
Typical Junction Resistance(Note 3)	$R_{\theta JL}$	20							$^\circ\text{C} / \text{W}$
Operating Junction and Storage Temperature Rating	T_J, T_{STG}	-50 TO +150							$^\circ\text{C}$

NOTES:1. Reverse Recovery Test Conditions: $I_F=0.5\text{A}$, $I_R=1.0\text{A}$, $I_{rr}=0.25\text{A}$
 2. Measured at 1 MHz and applied $V_r = 4.0$ volts.
 3. 8.0 mm² (.013mm thick) land areas.



RATING AND CHARACTERISTIC CURVES

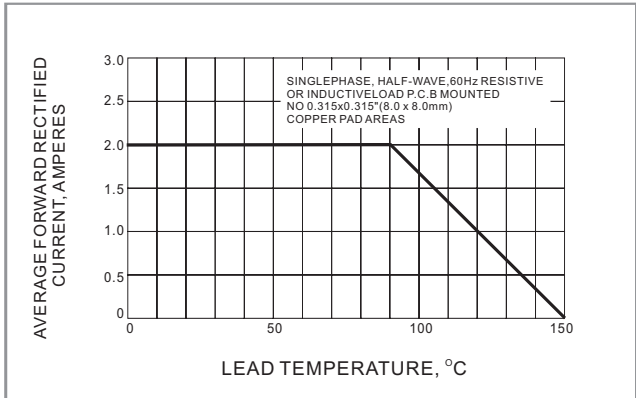

Fig.1 FORWARD CURRENT DERATING CURVE

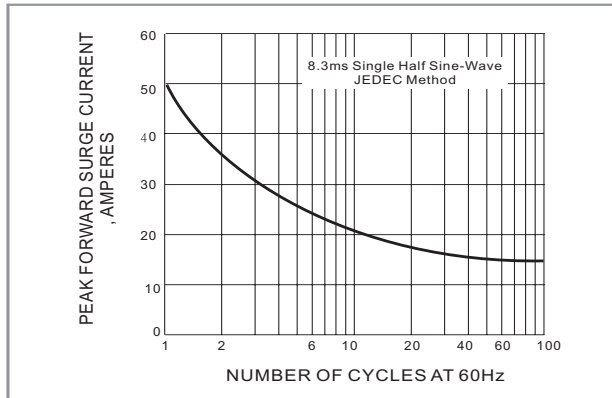

Fig.2-MAXIMUM NON-REPETITIVE PEAK FORWARD SURGE CURRENT

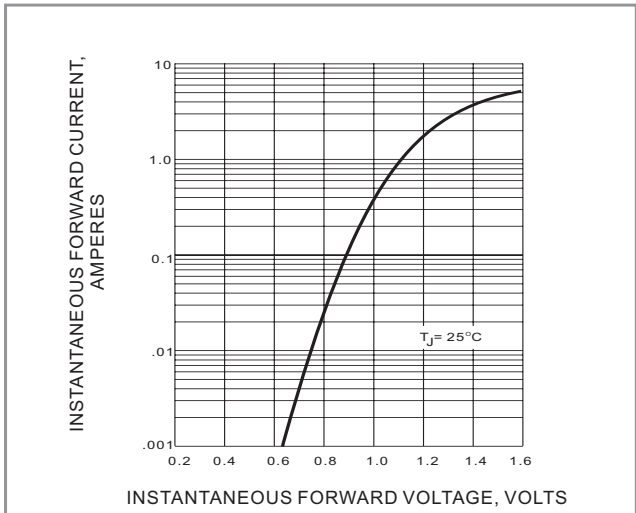

Fig.3-TYPICAL INSTANTANEOUS FORWARD CHARACTERISTICS

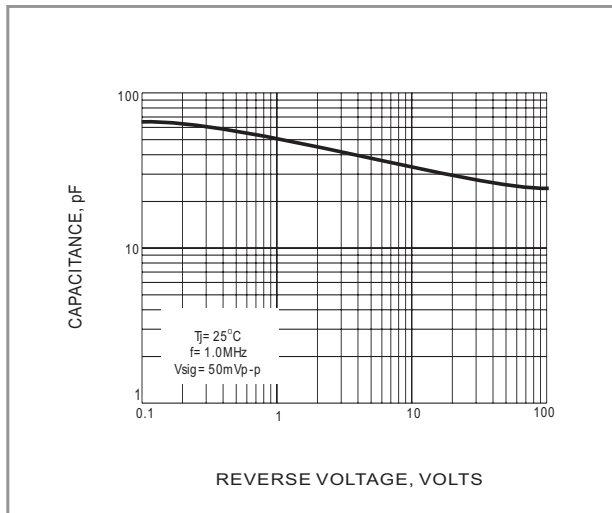
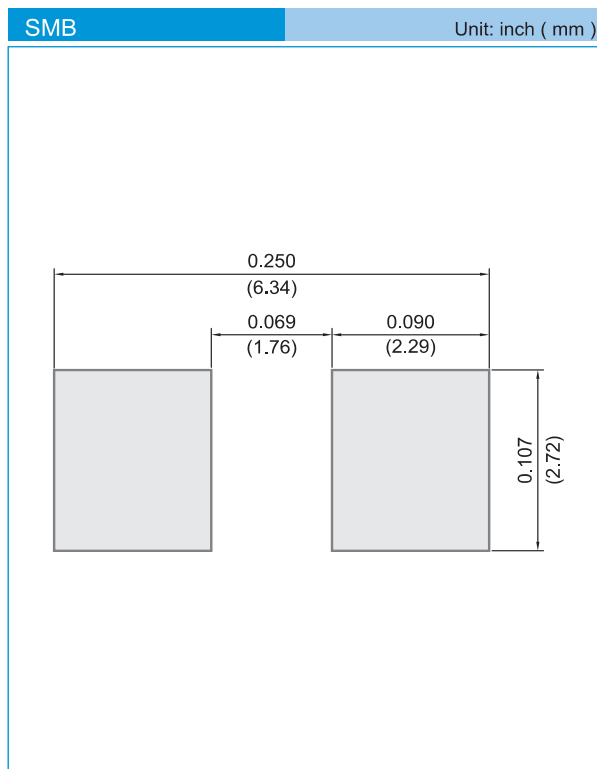

Fig.4 TYPICAL JUNCTION CAPACITANCE



MOUNTING PAD LAYOUT



ORDER INFORMATION

- Packing information
 - T/R - 3K per 13" plastic Reel
 - T/R - 0.5Kper 7" plastic Reel

LEGAL STATEMENT

Copyright PanJit International, Inc 2011

The information presented in this document is believed to be accurate and reliable. The specifications and information herein are subject to change without notice. Pan Jit makes no warranty, representation or guarantee regarding the suitability of its products for any particular purpose. Pan Jit products are not authorized for use in life support devices or systems. Pan Jit does not convey any license under its patent rights or rights of others.



2. MARKING

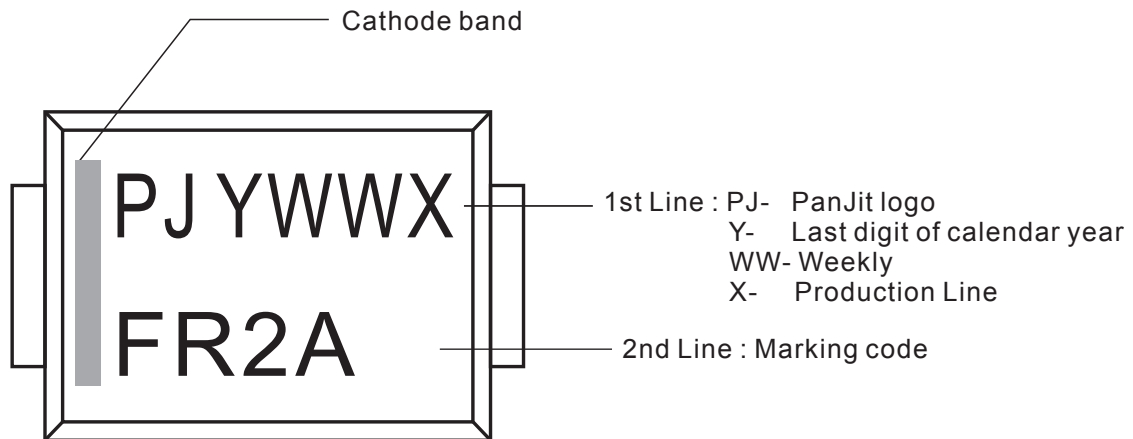



3. TAPING

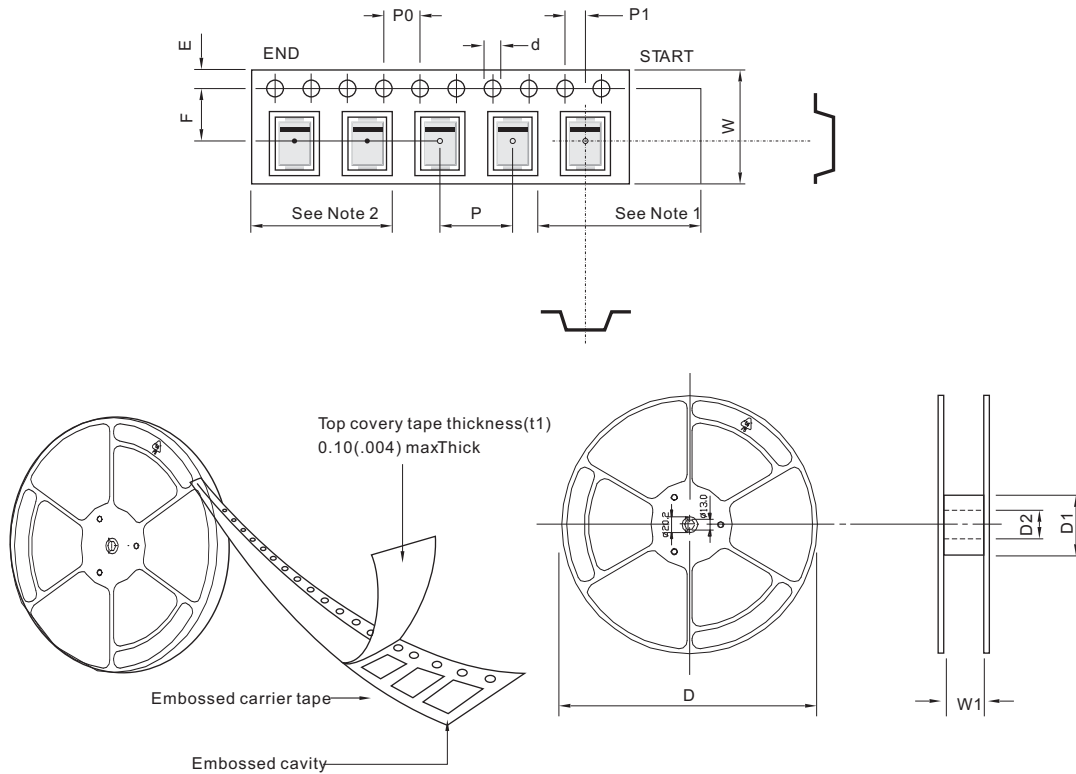

SYMBOL	mm(inch)	SYMBOL	mm(inch)	SYMBOL	mm(inch)
TYPE SIZE	12.00 (0.472)	TYPE SIZE	12.00 (0.472)	TYPE SIZE	16.00 (0.629)
Package	SMA/SMA(W)	Package	SMB	Package	SMC
d	1.55 +0.05 (0.06 +0.001)	d	1.55 +0.05 (0.06 +0.001)	d	1.55 ± 0.05 (0.06 ± 0.001)
D	178.0 +2.0 (7.0 +0.078)	D	178.0 +2.0 (13.0 +0.078)	D	178.0 ± 2.0 (13.0 ± 0.078)
D1	50.0 min (1.97 min)	D1	50.0 min (1.97 min)	D1	50.0 min (1.97 min)
D2	13.0 ± 0.2 (0.51 ± 0.007)	D2	13.0 ± 0.2 (0.51 ± 0.007)	D2	13.0 ± 0.5 (0.51 ± 0.019)
E	1.75 +0.10 (0.068 +0.003)	E	1.75 +0.10 (0.068 +0.003)	E	1.75 ± 0.10 (0.068 ± 0.003)
F	5.50 +0.1 (0.21 +0.003)	F	5.50 +0.05 (0.21 +0.001)	F	7.5 ± 0.10 (0.29 ± 0.003)
P	4.00 +0.10 (0.15 + 0.003)	P	8.00 +0.10 (0.31 + 0.003)	P	8.00 ± 0.10 (0.31 ± 0.003)
Po	4.00 +0.10 (0.15 +0.003)	Po	4.00 +0.10 (0.15 +0.003)	Po	4.00 ± 0.10 (0.15 ± 0.003)
P1	2.00 +0.1 (0.07 +0.003)	P1	2.00 +0.05 (0.07 +0.001)	P1	2.00 ± 0.10 (0.07 ± 0.003)
W	12.00 +0.3 (0.472 +0.118)	W	12.00 +0.3 (0.472 +0.118)	W	16.00 ± 0.3 (0.472 ± 0.118)
W1	12.40 ~ 14.40Maxmum (0.48 ~ 0.56)	W1	12.40 ~ 14.40Maxmum (0.48 ~ 0.56)	W1	16.40 ~ 18.40Maxmum (0.64 ~ 0.72)

Note:

1. There shall be leader of 230 mm minimum which may consist of carrier and or cover tape follower by a minimum of 160 mm of carrier tape sealed with cover tape.
2. There shall be minimum of 160 mm of empty component pockets sealed with cover tape.
3. Devices are packed in accordance whit EIA standard EIA-481-A and specifications given above.



4. PACKING

REEL PACKING

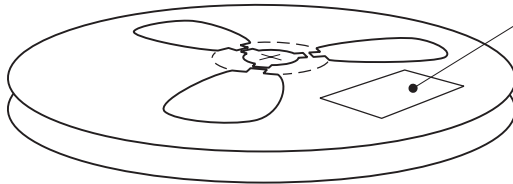

Quantity per Reel:

LABEL TYPE

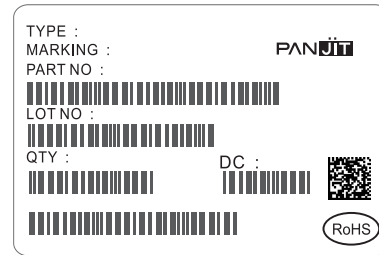

CARTON

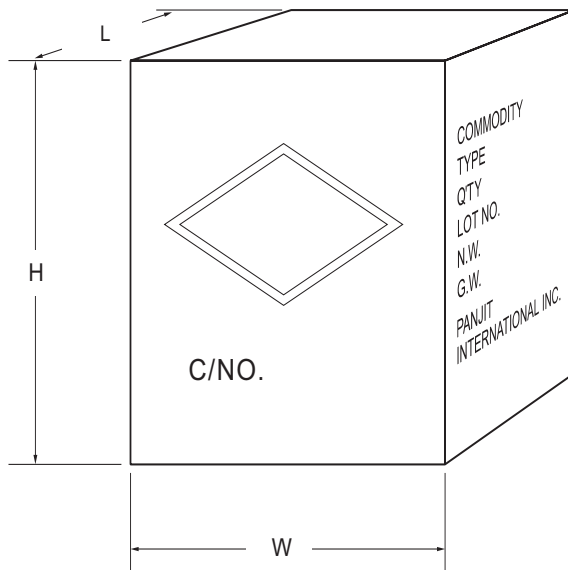

Box Dimensions : mm
Quantity per Box:

SHIPPING MARK

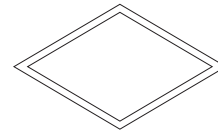

C/NO.
PRODUCT COUNTRY

SIDE MARK

COMMODITY:
TYPE:
Q'TY:
LOT NO.
N.W.
G.W.
PANJIT
INTERNATIONAL INC.

Line	Package	Packing	Size	Quantity	Inner box size LxWxH (m/m)	Carton Quantity	Carton size LxWxH (m/m)
SMD	SMA	T/R	7"	1,800	188x188x67	10box/72K	390x240x420
	SMB	T/R		500	188x188x67	10box/20K	390x240x420
	SMC	T/R		500	188x188x67	10box/15K	390x240x420
	SMA(W)	T/R	13"	1,800	188x188x67	10box/72K	390x240x420
	SMA	T/R		7,500	350x337x44	8box/120K	375x360x390
	SMB	T/R		3,000	350x337x44	8box/48K	375x360x390
	SMC	T/R		3,000	350x337x44	7box/42K	375x360x390
	SMA(W)	T/R		7,500	350x337x44	8box/120K	355x355x400



Packing Specifications

Package	Reel Size	Reel	Component Space	Tape Space	Reel Dia	Carton Size	Carton	Approx. Gross Weight
	(inch)	(pcs)	(m/m)	(m/m)	(m/m)	(m/m)	(EA)	(Kg)
Reel Packing								
DFN 2L	7	8,000	2	8	178	390 x 270 x 400	640,000	8.6
DFN 3L	7	8,000	2	8	178	390 x 270 x 400	640,000	8.6
SOD-123	7	3,000	4	8	178	390 x 270 x 400	240,000	9.9
	13	10,000	4	8	330	375 x 360 x 213	120,000	6.5
SOD-123FL	7	3,000	4	8	178	390 x 270 x 400	240,000	10.6
	13	10,000	4	8	330	375 x 360 x 213	120,000	7.2
SOD-123HE	7	3,000	4	8	178	390 x 270 x 400	240,000	12.4
	13	10,000	4	8	330	375 x 360 x 213	120,000	8.1
SOD-323	7	5,000	4	8	178	390 x 270 x 400	400,000	9.4
	13	12,000	4	8	330	375 x 360 x 213	144,000	5.9
SOD-323HE	7	5,000	4	8	178	390 x 270 x 400	400,000	11.9
	13	12,000	4	8	178	375 x 360 x 213	144,000	8.3
SOD-523	7	5,000	4	8	178	390 x 270 x 400	400,000	9.1
	13	12,000	4	8	330	375 x 360 x 213	144,000	5.4
SOD-723	7	8,000	2	8	178	390 x 270 x 400	640,000	8.5
SOD-923	7	8,000	2	8	178	390 x 270 x 400	640,000	7.7
SOT-23	7	3,000	4	8	178	390 x 270 x 400	240,000	9.8
	13	12,000	4	8	330	375 x 360 x 213	144,000	7
SOT-23 (ESD)	7	3,000	4	8	178	455 x 270 x 440	240,000	9.9
SOT-23 5L	7	3,000	4	8	178	390 x 270 x 400	240,000	14.5
	13	10,000	4	8	330	375 x 360 x 213	120,000	7.9
SOT-23 6L	7	3,000	4	8	178	390 x 270 x 400	240,000	14.5
	13	10,000	4	8	330	375 x 360 x 213	120,000	7.9
SOT-323	7	3,000	4	8	178	390 x 270 x 400	240,000	7.9
	13	12,000	4	8	330	375 x 360 x 213	144,000	6.1
SOT-323 (ESD)	7	3,000	4	8	178	455 x 270 x 440	240,000	9.4
SOT-353	7	3,000	4	8	178	390 x 270 x 400	240,000	10
	13	10,000	4	8	330	375 x 360 x 213	120,000	7.2
SOT-363	7	3,000	4	8	178	390 x 270 x 400	240,000	10.2
	13	10,000	4	8	330	375 x 360 x 213	120,000	7.1
SOT-363 (ESD)	7	3,000	4	8	178	455 x 270 x 440	240,000	10
SOT-523	7	4,000	4	8	178	390 x 270 x 400	320,000	10
SOT-543	7	4,000	4	8	178	390 x 270 x 400	320,000	9.4
	13	10,000	4	8	330	375 x 360 x 213	120,000	5.2
SOT-553	7	4,000	4	8	178	390 x 270 x 400	320,000	9.4
	13	10,000	4	8	330	375 x 360 x 213	120,000	5.2
SOT-563	7	4,000	4	8	178	390 x 270 x 400	320,000	9.4
	13	10,000	4	8	330	375 x 360 x 213	120,000	5.2
SOIC-08	13	3,000	8	12	330	375 x 360 x 213	48,000	14.2



Packing Specifications

Package	Reel Size	Reel	Component Space	Tape Space	Reel Dia	Carton Size	Carton	Approx. Gross Weight
	(inch)	(pcs)	(m/m)	(m/m)	(m/m)	(m/m)	(EA)	(Kg)
Reel Packing								
A-405	13	5,000	5	52	330	340 x 340 x 410	25,000	7.79
DO-15	13	4,000	5	52	330	340 x 340 x 410	20,000	11.4
DO-201AD	13	1,250	10	52	330	340 x 340 x 410	6,250	9.2
DO-201AE	13	1,250	10	52	330	340 x 340 x 410	6,250	9.2
DO-34	15	10,000	5	52	360	360 x 360 x 395	50,000	10.1
DO-35	15	10,000	5	52	360	360 x 360 x 395	50,000	11.2
DO-41	13	5,000	5	52	330	340 x 340 x 410	25,000	10.2
DO-41G	15	5,000	5	52	360	360 x 360 x 395	25,000	10.9
MDI	13	3,000	8	12	330	375 x 360 x 390	48,000	14.7
MELF/DL-41	7	1,500	4	-	178	385 x 380 x 260	84,000	18.3
	13	5,000	4	-	330	360 x 360 x 395	100,000	23.5
MICRO-MELF	7	2,500	4	-	178	385 x 380 x 260	200,000	9.3
	13	10,000	4	-	330	360 x 360 x 395	200,000	11.5
MINI-MELF/LL-34	7	2,500	4	-	178	385 x 380 x 260	200,000	12.7
	13	10,000	4	-	330	360 x 360 x 395	200,000	14.6
MICRO DIP/TDI	7	1,000	8	12	178	390 x 240 x 420	40,000	9.5
	13	4,000	8	12	330	375 x 360 x 390	64,000	17
P-600	13	800	10	52	330	340 x 340 x 410	4,000	9.9
QUADRO-MELF	13	10,000	4	-	330	360 x 360 x 395	200,000	14.9
	7	2,500	4	-	178	385 x 380 x 260	200,000	13.3
R-1	13	5,000	5	52	330	340 x 340 x 410	25,000	7.8
SDIP	13	1,500	12	16	330	375 x 360 x 390	21,000	14.3
SMA(W)	7	1,800	4	12	178	390 x 240 x 420	100,800	13
	13	7,500	4	12	330	355 x 355 x 400	150,000	20.4
SMA/DO-214AC	7	1,800	4	12	178	390 x 240 x 420	72,000	10
	13	7,500	4	12	330	375 x 360 x 390	120,000	17.4
SMB/DO-214AA	7	500	8	12	178	390 x 240 x 420	20,000	6.5
	13	3,000	8	12	330	375 x 360 x 390	48,000	13.2
SMC/DO-214AB	7	500	8	16	178	390 x 240 x 420	15,000	8.4
	13	3,000	8	16	330	375 x 360 x 390	42,000	18
TO-252/DPAK	13	3,000	8	16	330	375 x 360 x 390	42,000	18.8
TO-263/D ² PAK	13	800	16	24	330	375 x 360 x 390	6,400	14.5



Packing Specifications

Package	Inner Box Size	Box	Carton Size	Carton	Approx. Gross Weight
	(m/m)	(EA)	(m/m)	(EA)	(Kg)
Bulk Packing					
A-405	198 x 84 x 20	1,000	459 x 214 x 256	50,000	12.7
DO-15	200 x 85 x 25	1,000	459 x 214 x 256	40,000	20.7
DO-201AD	200 x 85 x 40	500	459 x 214 x 256	12,500	16
DO-201AE	200 x 85 x 40	500	495 x 214 x 256	12,500	16
DO-34	240 x 100 x 90	2,000	406 x 335 x 257	120,000	14.5
DO-35	240 x 100 x 90	2,000	406 x 335 x 257	120,000	17.1
DO-41	198 x 84 x 20	1,000	459 x 214 x 256	50,000	19.3
DO-41G	240 x 100 x 90	1,000	406 x 335 x 257	60,000	18.5
DIP	-	-	459 x 214 x 256	12,000	6.5
SDIP	-	-	459 x 214 x 256	24,000	15.7
R-1	198 x 84 x 20	1,000	459 x 214 x 256	50,000	12.7
P-600	208 x 90 x 83	500	459 x 214 x 256	5,000	11.3
ITO-220	540 x 145 x 85	2,000	555 x 306 x 200	8,000	20.5
TO-220	540 x 145 x 85	2,000	555 x 306 x 200	8,000	22.9
TO-251AB/DPAK	540 x 145 x 85	8,400	555 x 306 x 200	33,600	22
TO-3P/TO-247AD	-	-	530 x 243 x 100	1,500	13.9
TO-3PS/TO-247S	-	-	511 x 243 x 107	1,500	12.2

Package	Inner Box Size	Ammo	Component Space	Tape Space	Carton Size	Carton	Approx. Gross Weight
	(m/m)	(pcs)	(m/m)	(m/m)	(m/m)	(EA)	(Kg)
Ammunition Packing							
A-405	255 x 47 x 150	5,000	5	26	339 x 276 x 330	60,000	12.4
A-405	255 x 75 x 150	5,000	5	52	339 x 276 x 330	40,000	16
DO-15	255 x 75 x 150	3,000	5	52	339 x 276 x 330	24,000	13.3
DO-201AD	255 x 47 x 122	1,250	10	52	339 x 276 x 330	10,000	13.4
DO-201AE	255 x 47 x 122	1,250	10	52	339 x 276 x 330	10,000	13.4
DO-34	248 x 80 x 48	5,000	5	26	406 x 335 x 257	150,000	14.5
DO-34	248 x 80 x 75	5,000	5	52	406 x 335 x 257	100,000	12.7
DO-35	248 x 80 x 48	5,000	5	26	406 x 335 x 257	150,000	16.7
DO-35	248 x 80 x 75	5,000	5	52	406 x 335 x 257	100,000	15.2
DO-41	255 x 75 x 150	5,000	5	52	339 x 276 x 330	40,000	13.5
DO-41G	248 x 80 x 48	2,500	5	26	406 x 335 x 257	75,000	17.1
DO-41G	248 x 80 x 75	2,500	5	52	406 x 335 x 257	50,000	15.6
P-600	255 x 47 x 122	400	10	52	339 x 276 x 330	3,200	8.1
R-1	255 x 47 x 73	3,000	5	26	310 x 268 x 170	36,000	6.3
R-1	255 x 73 x 73	3,000	5	52	310 x 268 x 170	24,000	6.2
R-1	255 x 73 x 122	5,000	5	52	339 x 276 x 274	40,000	10.1

5.HIGH RELIABILITY TEST SPEC (Schottky & Switching & Rectifiers & Bridge)

Date : 2010.07.05 rev.01

NO.	TEST ITEM	TEST CONDITION	REFERENCED DOCUMENT	LOT QUALITY LEVEL
1	TEMPERATURE CYCLING (T.C.T) 溫度循環試驗	Ta = -55+0°C / -10°C 10min(Min) Ta = +150+15°C / -0°C 10min(Min) FOR 20CYCLES	MIL-STD-750D METHOD-1051.5 Condition G	LTPD 10 S.S=22 ACCEPT FOR 0 FAILURE ONLY.
2	HIGH TEMPERATURE STORAGE LIFE (H.T.S.L) 高溫儲存壽命試驗	Ta=Storage Temperature Range (device specified maximum temperature)	MIL-STD-750D METHOD-1032.2	LTPD 10 S.S=22 ACCEPT FOR 0 FAILURE ONLY.
3	SOLDERABILITY TEST 錫錫性試驗	Temperature of Solder TEMPERATURE OF SOLDER POT=245+/-5°C TIME FOR DIPPING IN SOLDER=5+/-0.5 SEC DIPPING DEPTH=0.05inch max from the body FOR ONE CYCLE	MIL-STD-750D METHOD-2026.10	LTPD 7 S.S=32 ACCEPT FOR 0 FAILURE ONLY.
4	HIGH TEMPERATURE REVERSE BIAS (H.T.R.B) 高溫逆向偏壓	Tj ≤ Tj max VR=0.8VR(CUSTOMER SPEC.) DC supply	MIL-STD-750D METHOD-1038.3	LTPD 10 S.S=22 ACCEPT FOR 0 FAILURE ONLY.
5	CONTINUE FORWARD OPERATING LIFE(C.F.O.L) 連續通電	Ta=25°C I = I _o +/- 10% DC supply	MIL-STD-750D METHOD 1027.3	LTPD 10 S.S=22 ACCEPT FOR 0 FAILURE ONLY.
6	THERMAL SHOCK (T.S.T) 冷熱衝擊試驗	HOT TANK Ta=100+10/-2°C t= 5min COLD TANK Ta=0+2/-10°C t= 5min 15 CYCLES TIME BETWEEN TRANSFERRING DO NOT EXCEED 10 SEC	MIL-STD-750D METHOD 1056.7	LTPD 10 S.S=22 ACCEPT FOR 0 FAILURE ONLY.
7	PRESSURE COOKER (P.C.T) 壓力鍋試驗	Ta=121°C P=29.7psia / 205kPa or 2.088kg/cm ² Relative Humidity = 100%	JEDEC JESD22-A102-C	LTPD 10 S.S=22 ACCEPT FOR 0 FAILURE ONLY.
8	INTERMITTENT FORWARD OPERATING LIFE (I.F.O.L) 斷續通電	I = I _o x 1.0 DC supply POWER ON: at least 30 SEC POWER OFF: 50 SEC TESTING CYCLE: 2000CYCLES	MIL-STD-750D METHOD 1036.3	LTPD 10 S.S=22 ACCEPT FOR 0 FAILURE ONLY.
9	FORWARD SURGE CURRENT 順向突波電流測試	SQ WAVE OR SINE WAVE IFSM=DATE SHEET SPEC. TIME=Single half sine wave T= 1 CYCLE	MIL-STD-750D METHOD 4066-3	LTPD 10 S.S=22 ACCEPT FOR 0 FAILURE ONLY.
10	HUMIDITY 恆溫濕試驗	Ta=85+/-2°C RH=85+/-5%	EIAJ ED-4701 METHOD 103	LTPD 10 S.S=22 ACCEPT FOR 0 FAILURE ONLY.
11	SOLDER RESISTANCE 錫錫耐熱性試驗	TEMPERATURE OF SOLDER POT=260+/-5°C TIME FOR DIPPING IN SOLDER=10+2/-0 SEC DIPPING DEPTH=1.57+/-0.79mm FROM THE BODY FOR ONE CYCLE	MIL-STD-750D METHOD 2031.2	LTPD 10 S.S=22 ACCEPT FOR 0 FAILURE ONLY.