



SB1620CT~SB1660CT

ISOLATION SCHOTTKY BARRIER RECTIFIERS

VOLTAGE 20 to 60 Volts **CURRENT** 16 Amperes

TO-220AB Unit: inch (mm)

FEATURES

- Plastic package has Underwriters Laboratory Flammability Classification 94V-O utilizing Flame Retardant Epoxy Molding Compound.
- Exceeds environmental standards of MIL-S-19500/228
- Low power loss, high efficiency.
- Low forward voltage, high current capability
- High surge capacity.
- For use in low voltage, high frequency inverters free wheeling, and polarity protection applications.
- In compliance with EU RoHS 2002/95/EC directives

MECHANICAL DATA

- Case: TO-220AB molded plastic package
- Terminals: Lead solderable per MIL-STD-750, Method 2026
- Polarity: As marked.
- Mounting Position: Any
- Weight: 0.0655 ounces, 1.859 grams.

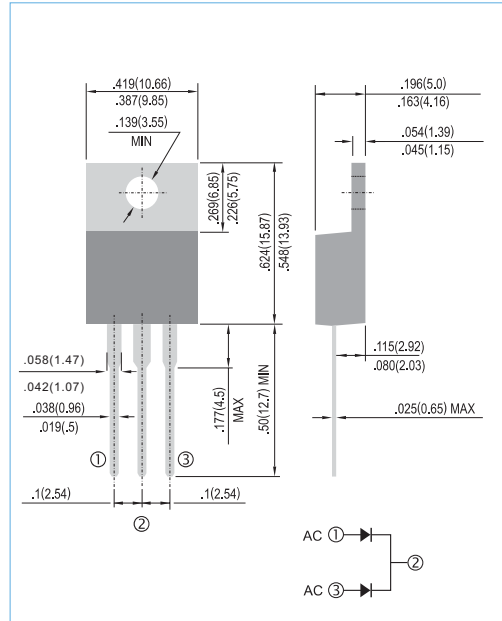

MAXIMUM RATINGS AND ELECTRICAL CHARACTERISTICS

Ratings at 25°C ambient temperature unless otherwise specified. Single phase, half wave, 60 Hz, resistive or inductive load.

For capacitive load, derate current by 20%

PARAMETER	SYMBOL	SB1620CT	SB1630CT	SB1640CT	SB1645CT	SB1650CT	SB1660CT	UNITS
Maximum Recurrent Peak Reverse Voltage	V_{RRM}	20	30	40	45	50	60	V
Maximum RMS Voltage	V_{RMS}	14	21	28	31.5	35	42	V
Maximum DC Blocking Voltage	V_{DC}	20	30	40	45	50	60	V
Maximum Average Forward Current lead length at $T_c=75^\circ\text{C}$	$I_{F(AV)}$	16						A
Peak Forward Surge Current :8.3ms single half sine-wave superimposed on rated load(JEDEC method)	I_{FSM}	150						A
Maximum Forward Voltage at 8.0A per leg	V_F	0.55				0.75		V
Maximum DC Reverse Current at $T_j=25^\circ\text{C}$ Rated DC Blocking Voltage $T_j=100^\circ\text{C}$	I_R	0.2			0.1			mA
Typical Thermal Resistance	$R_{\theta JC}$	2.0						$^\circ\text{C} / \text{W}$
Operating Junction Temperature Range	T_J	-55 to +125			-55 to +150			$^\circ\text{C}$
Storage Temperature Range	T_{STG}	-55 to +150						$^\circ\text{C}$

NOTES:

Both Bonding and Chip structure are available.



SB1620CT~SB1660CT

RATING AND CHARACTERISTIC CURVES

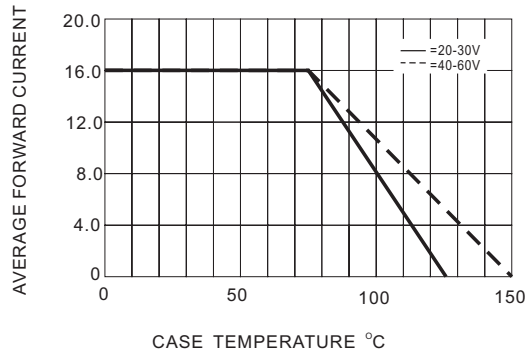

Fig.1- FORWARD CURRENT DERATING CURVE

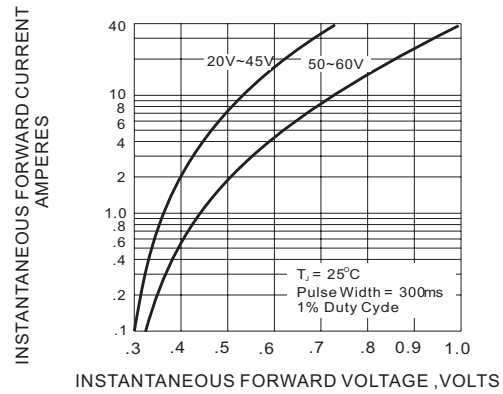

Fig.2- TYPICAL INSTANTANEOUS FORWARD CHARACTERISTICS

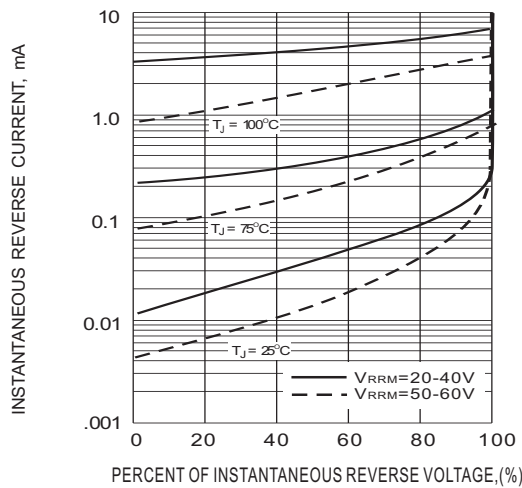

Fig.3- TYPICAL REVERSE CHARACTERISTICS

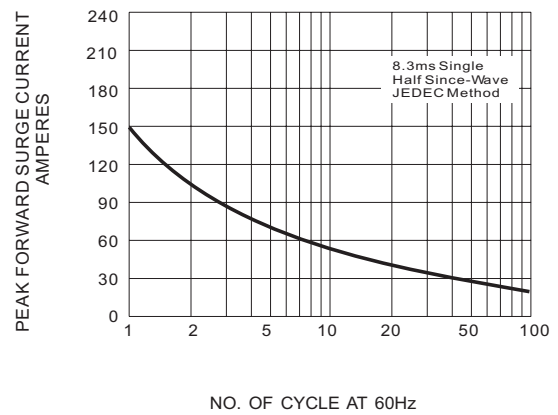

Fig.4- MAXIMUM NON-REPETITIVE SURGE CURRENT



2. MARKING

