



# QRT1506/QRT1506F/QRT1506D

## PLANAR STRUCTURED SUPERFAST RECOVERY RECTIFIERS

**VOLTAGE** 600 Volt **CURRENT** 15 Ampere

### FEATURES

- Planar structure with EPI wafer
- Hyperfast recovery time, reduced Qrr and soft recovery
- For PFC CCM operation
- Low leakage current
- Plastic package has Underwriters Laboratory Flammability Classification 94V-O Flame Retardant Epoxy Molding Compound
- Exceeds environmental standards of MIL-S-19500/228
- Lead free in compliance with EU RoHS 2011/65/EU directive

### MECHANICAL DATA

- Case: TO-220AC, ITO-220AC, TO-263 package
- Terminals: Lead solderable per MIL-STD-750, Method 2026
- TO-220AC Weight: 0.065 ounces, 1.859 grams
- ITO-220AC Weight: 0.055 ounces, 1.5615 grams
- TO-263 Weight: 0.051 ounces, 1.46 grams

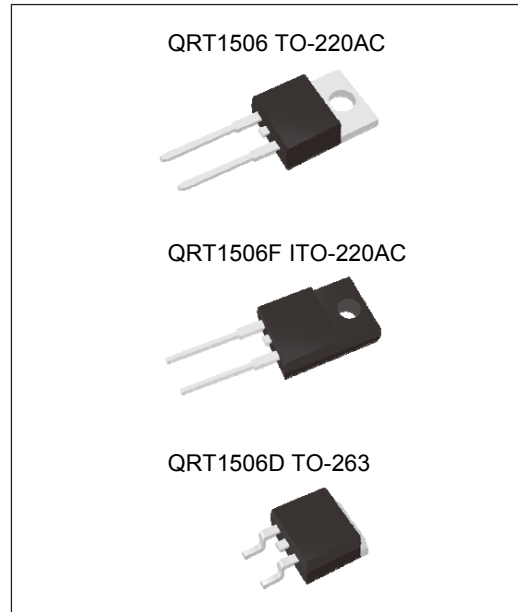

### MAXIMUM RATINGS(T<sub>A</sub>=25°C unless otherwise noted)

PARAMETER	SYMBOL	VALUE	UNIT
Maximum recurrent peak reverse voltage	V <sub>RRM</sub>	600	V
Maximum rms voltage	V <sub>RMS</sub>	420	V
Maximum dc blocking voltage	V <sub>R</sub>	600	V
Maximum average forward rectified current	I <sub>F(AV)</sub>	15	A
Peak forward surge current 8.3ms single half sine-wave superimposed on rated load	I <sub>FSM</sub>	150	A
Typical thermal resistance	R <sub>θJC</sub>	TO-220AC(Note 1)	2
		ITO-220AC(Note 1)	5.5
		TO-263 (Note 1)	2
Operating junction temperature range	T <sub>J</sub>	-55 to + 175	°C
Storage temperature range	T <sub>STG</sub>	-55 to + 175	°C

NOTE :

1. Device mounted on a infinite heatsink , then measured the center of the marking side.



## QRT1506/QRT1506F/QRT1506D

### ELECTRICAL CHARACTERISTICS(T<sub>A</sub>=25°C unless otherwise noted)

PARAMETER	SYMBOL	TEST CONDITIONS	MIN.	TYP.	MAX.	UNIT
Breakdown voltage	V <sub>BR</sub>	I <sub>R</sub> =100μA	600	-	-	V
Instantaneous forward voltage	V <sub>F</sub>	I <sub>F</sub> =1A	-	1	-	V
		I <sub>F</sub> =5A	-	1.53	-	
		I <sub>F</sub> =15A	-	2.13	2.35	
		T <sub>J</sub> =25°C	-	-	-	-
		I <sub>F</sub> =1A	-	0.64	-	V
		I <sub>F</sub> =5A	-	0.97	-	
		I <sub>F</sub> =15A	-	1.36	1.55	
T <sub>J</sub> =125°C	-	-	-	-		
Reverse leakage current	I <sub>R</sub>	V <sub>R</sub> =600V	-	-	3	μA
Reverse recovery time	T <sub>RR</sub>	I <sub>F</sub> =0.5A	-	-	30	ns
		I <sub>R</sub> =1A	-	-	-	
		I <sub>RR</sub> =0.25A	-	-	-	
		I <sub>F</sub> =1A	-	-	25	ns
		V <sub>R</sub> =30V	-	-	-	
		di/dt=100A/μs	-	-	-	
Peak recovery current	I <sub>RRM</sub>	I <sub>F</sub> =15A	-	2.5	-	A
		V <sub>R</sub> =400V	-	-	-	
		di/dt=200A/μs	-	-	-	
Reverse recovery charge	Q <sub>RR</sub>	I <sub>F</sub> =15A	-	55	-	nC
		V <sub>R</sub> =400V	-	-	-	
		di/dt=200A/μs	-	-	-	



# QRT1506/QRT1506F/QRT1506D

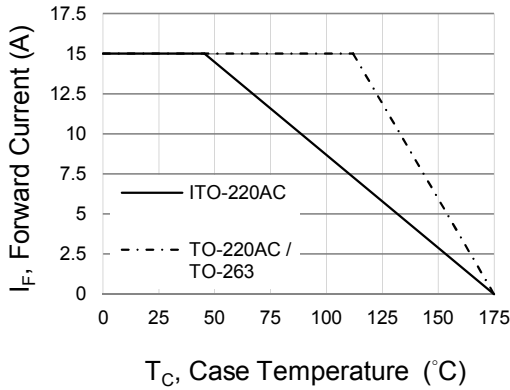

**Fig.1 Forward Current Derating Curve**

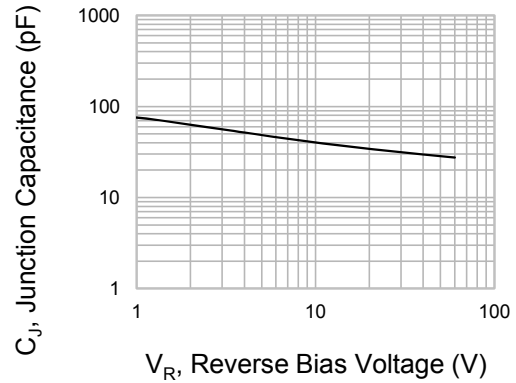

**Fig.2 Typical Junction Capacitance**

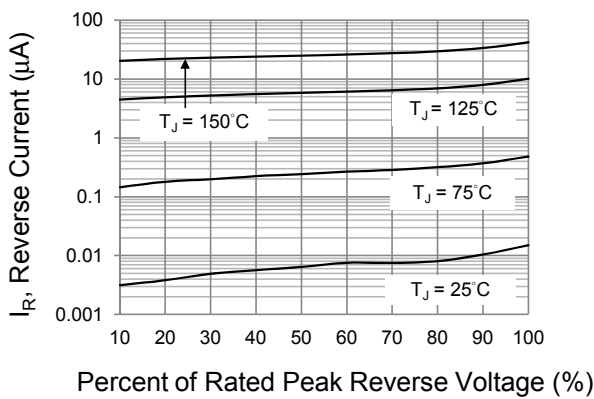

**Fig.3 Typical Reverse Characteristics**

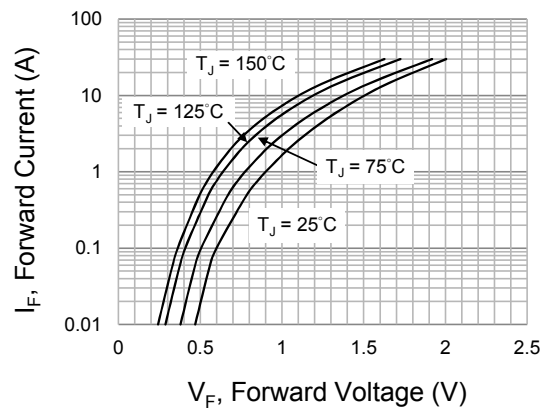

**Fig.4 Typical Forward Characteristics**

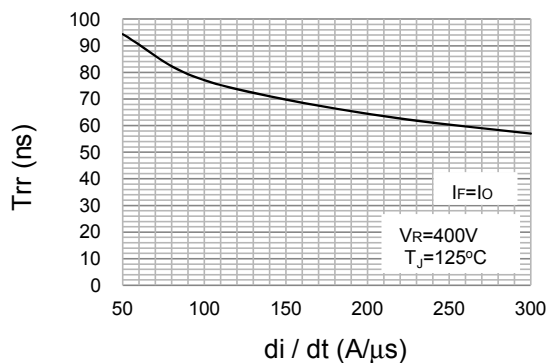

**Fig.5 Typical Reverse recovery time versus di/dt**

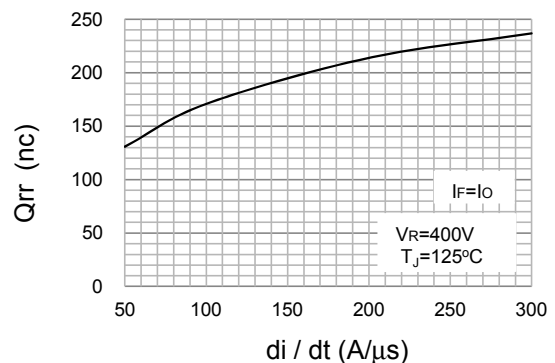

**Fig.6 Typical Reverse recovery charges versus di/dt**



**QRT1506/QRT1506F/QRT1506D**

**TO-220AC**

Unit : inch(mm)

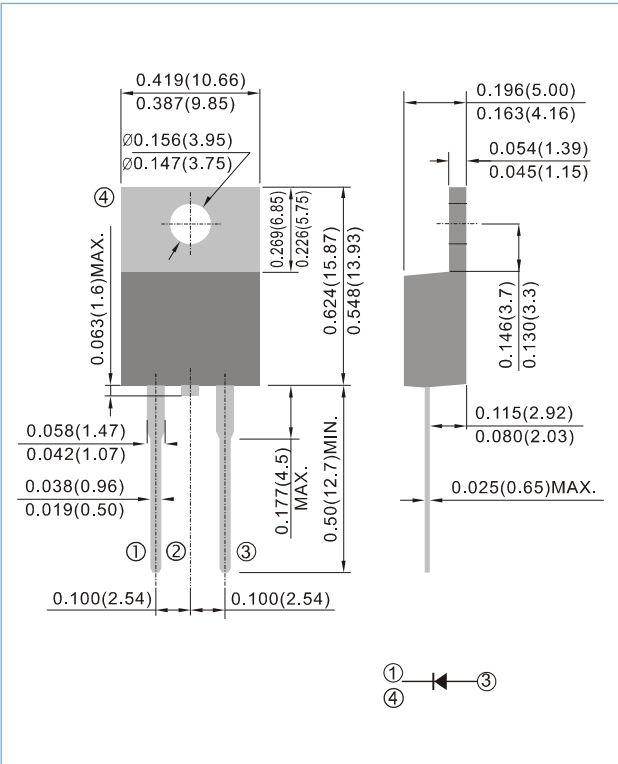

**ITO-220AC**

Unit : inch(mm)

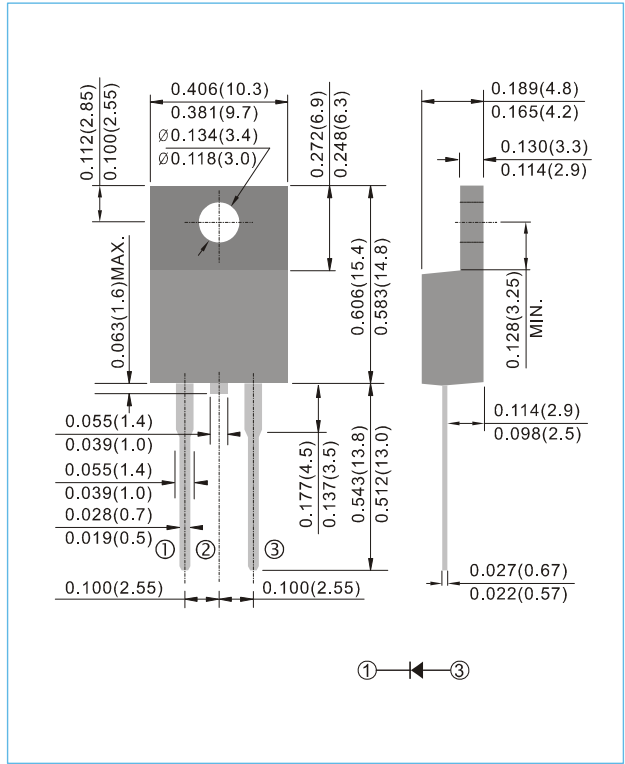

**TO-263 / D<sup>2</sup>PAK**

Unit : inch(mm)

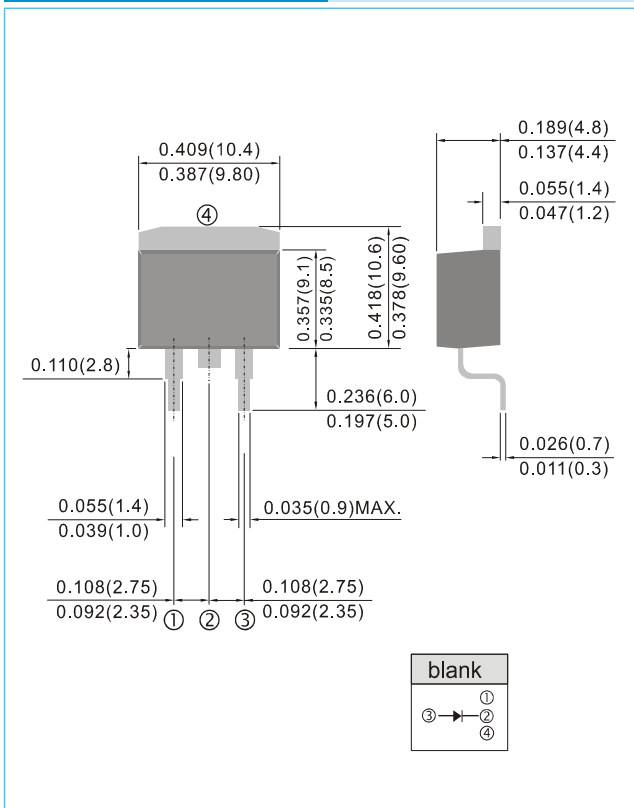



# QRT1506/QRT1506F/QRT1506D

## MOUNTING PAD LAYOUT

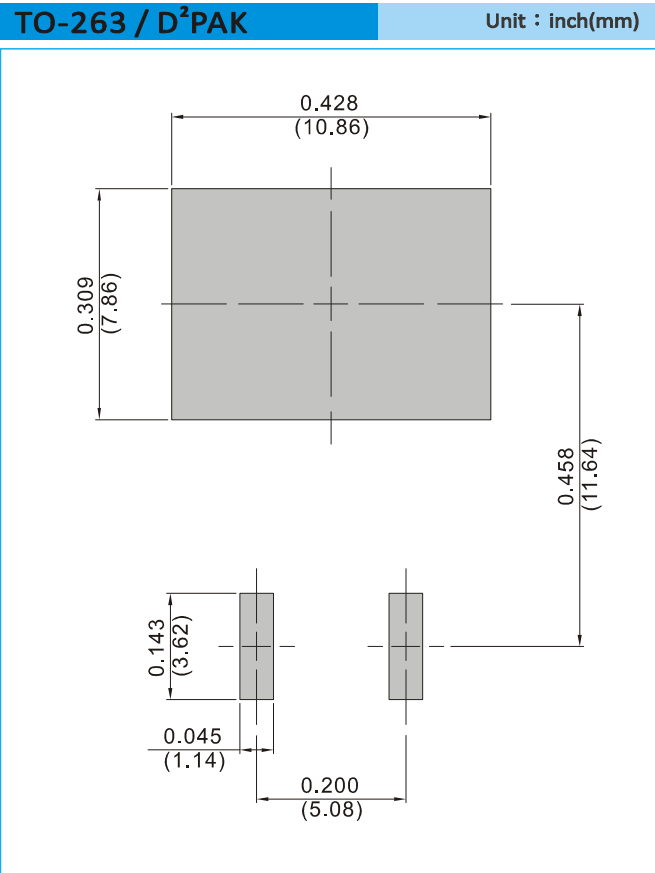

## ORDER INFORMATION

- Packing information  
T/R - 0.8K per 13" plastic Reel