



PJEC3V3M1FN2

Low Capacitance TVS/ESD Protection

V_{RWM}

3.3 V

Features

- Bidirectional ESD protection of one line
- IEC61000-4-2(ESD): $\pm 15kV$ Air, $\pm 8kV$ Contact Compliance with the capability up to $\pm 30kV$
- IEC61000-4-4(EFT): 40A(5/50nS)
- IEC61000-4-5(Lightning): 5A(8/20 μ S)
- Low leakage current, maximum of 0.5 μ A at rated voltage
- Lead free in compliance with EU RoHS 2.0
- Green molding compound as per IEC 61249 standard

Mechanical Data

- Case: DFN 2L, Plastic
- Terminals: Solderable per MIL-STD-750, Method 2026
- Approx. Weight: 0.00004 ounces, 0.0011 grams
- Marking: BG

Applications

- Mobile Phones and accessories
- Desktops, Servers and Notebook
- Hand held portable
- Digital Cameras
- Computer Interfaces Protection
- Serial and Parallel Ports Protection
- Control Signal Lines Protection

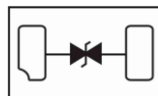
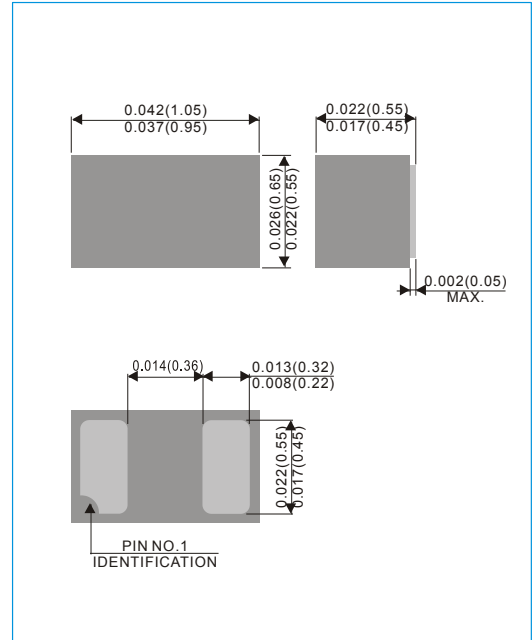

Fig.166(Top View)

DFN 2L

Unit : inch(mm)



Maximum Ratings ($T_A=25^{\circ}C$ unless otherwise noted)

PARAMETER	SYMBOL	LIMIT	UNITS
ESD IEC61000-4-2(Air)	V_{ESD}	± 30	kV
ESD IEC61000-4-2(Contact)		± 30	
Operating Junction Temperature	T_J	-55 to +125	$^{\circ}C$
Storage Temperature Range	T_{STG}	-55 to +150	$^{\circ}C$



PJEC3V3M1FN2

Electrical Characteristics ($T_A=25^{\circ}\text{C}$ unless otherwise noted)

PARAMETER	SYMBOL	TEST CONDITION	MIN.	TYP.	MAX.	UNITS
Reverse Stand-Off Voltage	V_{RWM}	-	-	-	3.3	V
Punch-Trough Voltage	V_{PT}	$I_{PT}=2\mu\text{A}$	3.5	-	-	V
Snap-Break Voltage	V_{SB}	$I_{SB}=50\text{mA}$	2.8	-	-	V
Reverse Leakage Current	I_R	$V_R=3.3\text{V}$	-	-	0.5	μA
Clamping Voltage	V_{CL}	$I_{PP}=1\text{A}, t_P=8/20\mu\text{s}$	-	-	6	V
		$I_{PP}=5\text{A}, t_P=8/20\mu\text{s}$	-	-	8	
Clamping Voltage TLP (Note 1)	V_{CL}	$I_{PP}=4\text{A}, t_P=100\text{ns}$	-	6	-	V
		$I_{PP}=8\text{A}, t_P=100\text{ns}$	-	7	-	
Dynamic Resistance	R_{DYN}	$t_P=100\text{ns}$	-	0.25	-	Ω
Off State Junction Capacitance	C_J	0Vdc Bias $f=1\text{MHz}$	-	-	10	pF

NOTE :

1. Testing using Transmission Line Pulse (TLP) conditions: $Z_0 = 50\Omega$, $t_P = 100\text{ns}$.



PJEC3V3M1FN2

TYPICAL CHARACTERISTIC CURVES

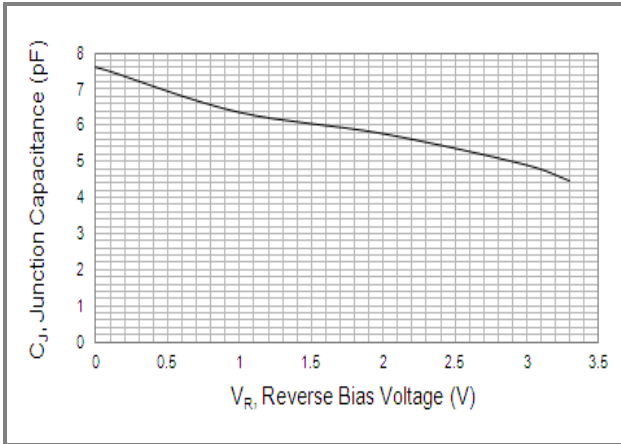

Fig.1 Typical Junction Capacitance

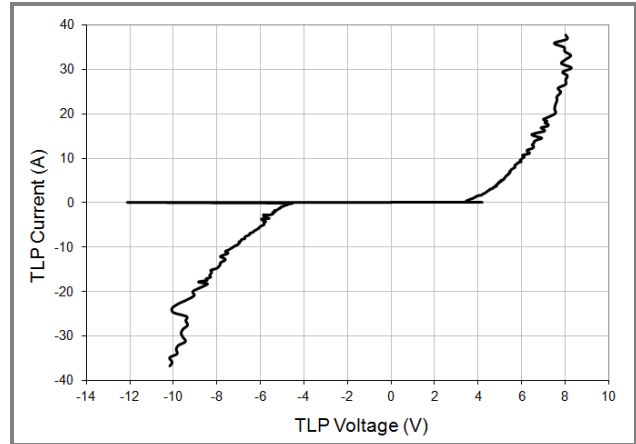

Fig.2 Transmission Line Pulsing (TLP) Measurement

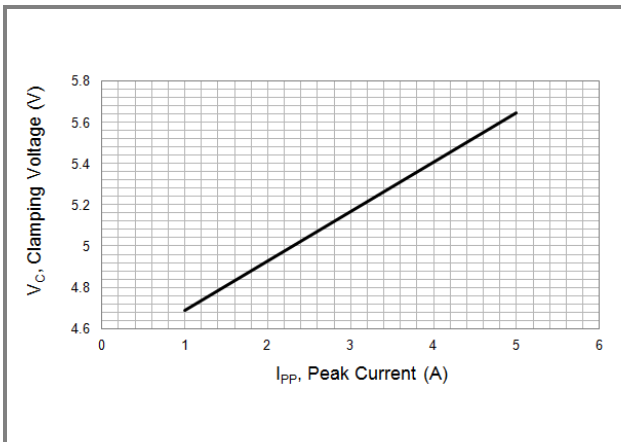

Fig.3 Typical Peak Clamping Voltage(8/20µs)

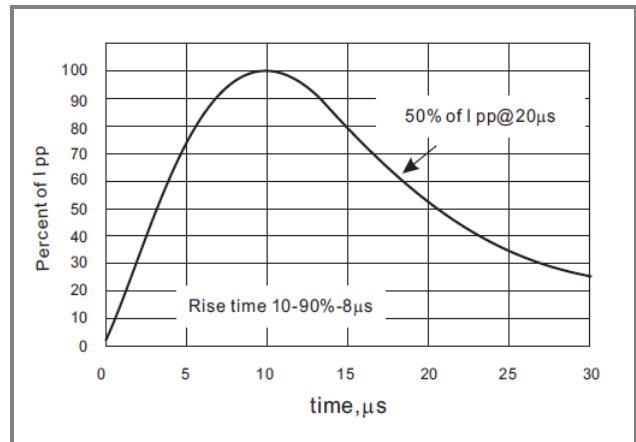

Fig.4 8/20µs Pulse Waveform



PJEC3V3M1FN2

MOUNTING PAD LAYOUT

DFN 2L

Unit : inch(mm)

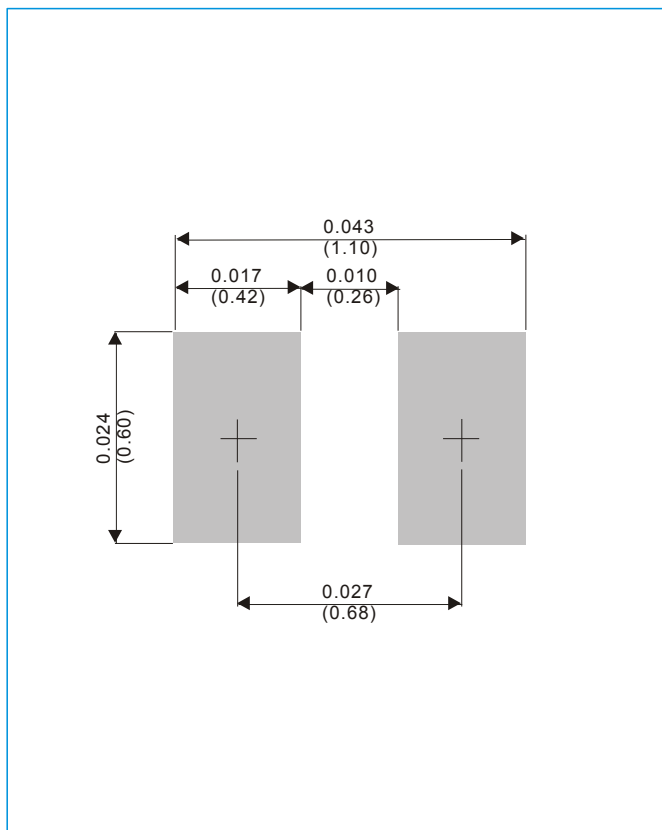

ORDER INFORMATION

- Packing information
T/R – 8K per 7" plastic Reel



PJEC3V3M1FN2

Part No._packing code_Version

PJEC3V3M1FN2_R1_00001

For example :

RB500V-40_R2_00001

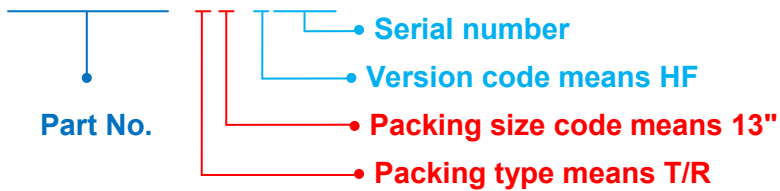

Packing Code XX				Version Code XXXXX		
Packing type	1 st Code	Packing size code	2 nd Code	HF or RoHS	1 st Code	2 nd ~5 th Code
Tape and Ammunition Box (T/B)	A	N/A	0	HF	0	serial number
Tape and Reel (T/R)	R	7"	1	RoHS	1	serial number
Bulk Packing (B/P)	B	13"	2			
Tube Packing (T/P)	T	26mm	X			
Tape and Reel (Right Oriented) (TRR)	S	52mm	Y			
Tape and Reel (Left Oriented) (TRL)	L	PANASERT T/B CATHODE UP (PBCU)	U			
FORMING	F	PANASERT T/B CATHODE DOWN (PBCD)	D			



PJEC3V3M1FN2

Disclaimer

- Reproducing and modifying information of the document is prohibited without permission from Panjit International Inc..
- Panjit International Inc. reserves the rights to make changes of the content herein the document anytime without notification. Please refer to our website for the latest document.
- Panjit International Inc. disclaims any and all liability arising out of the application or use of any product including damages incidentally and consequentially occurred.
- Panjit International Inc. does not assume any and all implied warranties, including warranties of fitness for particular purpose, non-infringement and merchantability.
- Applications shown on the herein document are examples of standard use and operation. Customers are responsible in comprehending the suitable use in particular applications. Panjit International Inc. makes no representation or warranty that such applications will be suitable for the specified use without further testing or modification.
- The products shown herein are not designed and authorized for equipments requiring high level of reliability or relating to human life and for any applications concerning life-saving or life-sustaining, such as medical instruments, transportation equipment, aerospace machinery et cetera. Customers using or selling these products for use in such applications do so at their own risk and agree to fully indemnify Panjit International Inc. for any damages resulting from such improper use or sale.
- Since Panjit uses lot number as the tracking base, please provide the lot number for tracking when complaining.