



**TABLE OF CONTENTS**

1.DATA SHEET

PAGE 1

2.MARKING

PAGE 3

3.PACKING

PAGE 4

4.HIGH RELIABILITY TESTING SPEC.

PAGE 7



# 1. DATA SHEET

## SB1020~SB10100

### SCHOTTKY BARRIER RECTIFIERS

**VOLTAGE** 20 to 100 Volts **CURRENT** 10 Amperes

TO-220AC

Unit : inch (mm)

#### FEATURES

- Plastic package has Underwriters Laboratory Flammability Classification 94V-O. Flame Retardant Epoxy Molding Compound.
- Exceeds environmental standards of MIL-S-19500/228
- Low power loss, high efficiency.
- Low forward voltage, high current capability
- High surge capacity.
- For use in low voltage, high frequency inverters free wheeling, and polarity protection applications.
- Both normal and Pb free product are available :  
Normal : 80~95% Sn, 5~20% Pb  
Pb free: 98.5% Sn above

#### MECHANICAL DATA

Case: TO-220AC Molded plastic  
Terminals: Solder plated, solderable per MIL-STD-202, Method 208  
Polarity: As marked.  
Standard packaging: Any  
Weight: 0.08 ounces, 2.24grams.

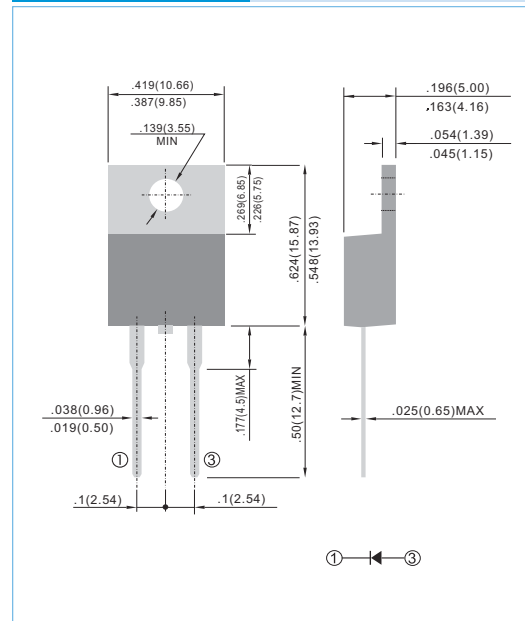

#### MAXIMUM RATINGS AND ELECTRICAL CHARACTERISTICS

Ratings at 25°C ambient temperature unless otherwise specified. Single phase, half wave, 60 Hz, resistive or inductive load.  
For capacitive load, derate current by 20%

PARAMETER	SYMBOL	SB1020	SB1030	SB1040	SB1050	SB1060	SB1080	SB10100	UNITS
Maximum Recurrent Peak Reverse Voltage	V <sub>RRM</sub>	20	30	40	50	60	80	100	V
Maximum RMS Voltage	V <sub>RMS</sub>	14	21	28	35	42	56	70	V
Maximum DC Blocking Voltage	V <sub>DC</sub>	20	30	40	50	60	80	100	V
Maximum Average Forward Current .375"(9.5mm) lead length at T <sub>c</sub> =100°C	I <sub>AV</sub>	10							A
Peak Forward Surge Current :8.3ms single half sine-wave superimposed on rated load(JEDEC method)	I <sub>FSM</sub>	150							A
Maximum Forward Voltage at 10A,	V <sub>F</sub>	0.55		0.75		0.85			V
Maximum DC Reverse Current at TA=25°C Rated DC Blocking Voltage TA=100°C	I <sub>R</sub>				0.5 50		mA		
Typical Thermal Resistance	R <sub>θJC</sub>	3.0							°C / W
Operating Junction and Storage Temperature Range	T <sub>J</sub> ,T <sub>STG</sub>	-50 TO +125							°C

Note.

Both Bonding and Chip structure are available.



**RATING AND CHARACTERISTIC CURVES**

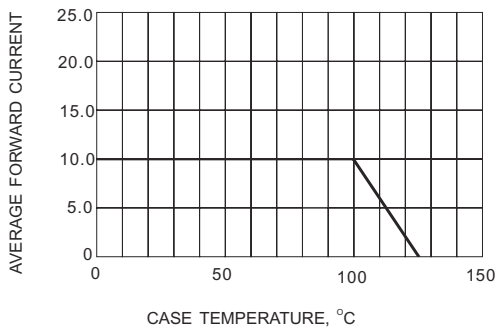

Fig.1- FORWARD CURRENT DERATING CURVE

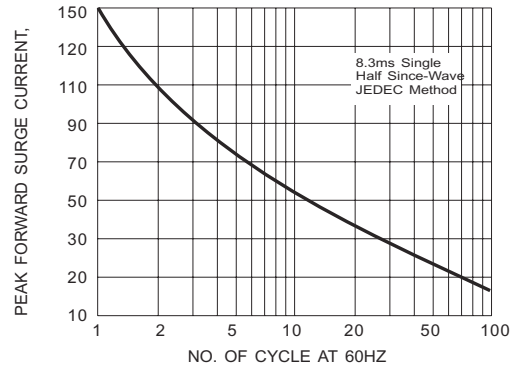

Fig.2- MAXIMUM NON-REPETITIVE SURGE CURRENT

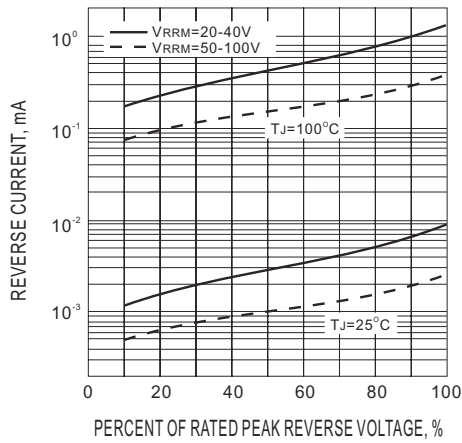

Fig.3- TYPICAL REVERSE CHARACTERISTIC

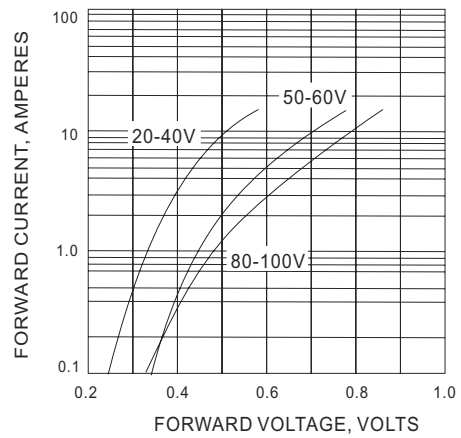
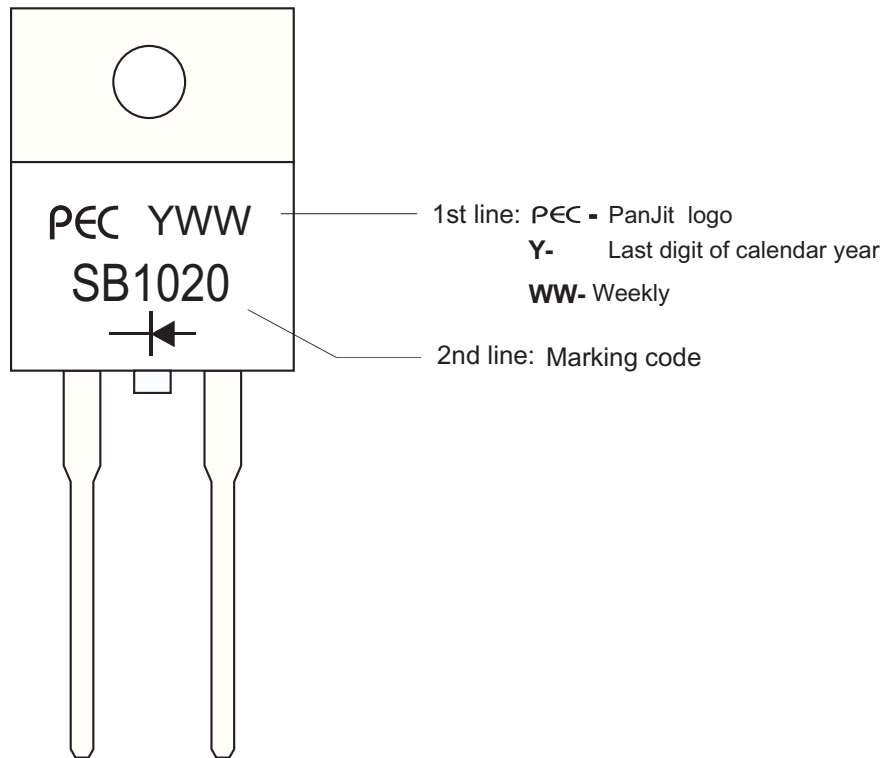

Fig.4- TYPICAL INSTANTANEOUS FORWARD CHARACTERISTIC



## 2. MARKING





### 3. PACKING

#### INNER BOX

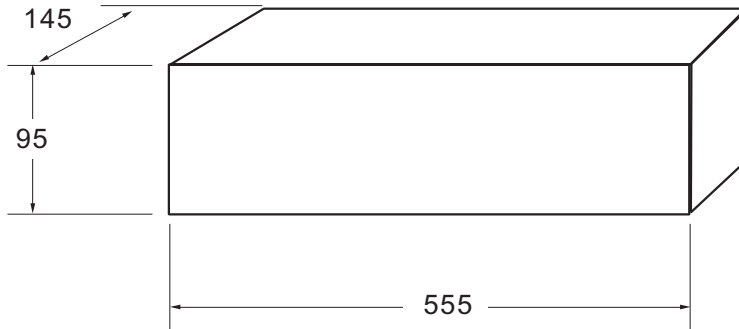

Box Dimensions : mm  
Quantity per Carton: 2,000 pcs

#### CARTON

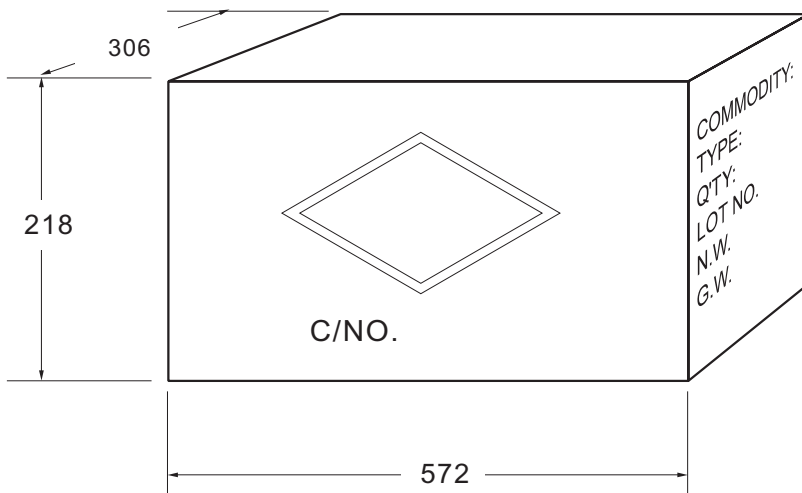

Box Dimensions : mm  
Quantity per Box: 8,000 pcs

#### SHIPPING MARK

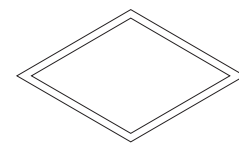

C/NO.  
PRODUCT COUNTRY

#### SIDE MARK

COMMODITY:  
TYPE:  
Q'TY:  
LOT NO.  
N.W.  
G.W.  
PANJIT  
INTERNATIONAL INC.



## Bulk Packing

PACKAGE	INNER SIZE	BOX	CARTON SIZE	CARTON	APPROX. GROSS WEIGHT
	(m/m)	(EA)	(m/m)	(EA)	(Kg)
<b>Bulk Packing</b>					
R-1	198 x 84 x 20	1,000	459 x 214 x 256	50,000	12.4
A-405	198 x 84 x 20	1,000	459 x 214 x 256	50,000	13.4
DO-35	96 x 80 x 42	10,000	410 x 350 x 275	120,000	21.5
DO-41G	240 x 100 x 100	5,000	410 x 350 x 275	60,000	26.5
DO-41	198 x 84 x 20	1,000	459 x 214 x 256	50,000	19.1
DO-15	200 x 85 x 25	1,000	459 x 214 x 256	40,000	17.5
DO-201AE	200 x 85 x 40	500	459 x 214 x 256	12,500	17.0
DO-201AD	200 x 85 x 40	500	459 x 214 x 256	12,500	17.3
P600	208 x 90 x 83	500	459 x 214 x 256	5,000	11.3
AM	195 x 195 x 40	1,000	400 x 273 x 415	10,000	16.8
DIP	-	-	459 x 214 x 256	12,000	10.2
SDIP	-	-	459 x 214 x 256	24,000	15.5
FL	230 x 230 x 50	500	495 x 245 x 180	3,000	25.0
GBU	350 x 337 x 44	800	510 x 340 x 235	3,200	18.9
ITO/TO-220	555 x 145 x 95	2,000	570 x 306 x 218	8,000	13.4
GL	260 x 190 x 75	72	460 x 215 x 260	864	15.8
KBU	230 x 230 x 50	400	495 x 245 x 180	2,400	21.5
GBJ	352 x 337 x 44	600	375 x 360 x 213	2,400	13.1
TO-251AB	560 x 210 x 79	8,000	577 x 226 x 196	16,000	6.5
GBL	352 x 337 x 44	960	375 x 360 x 213	3,840	13.0
GBP	352 x 337 x 44	1,120	375 x 360 x 213	4,480	11.3
TO-3P	-	-	536 x 243 x 100	1,500	12.7
GBPC/W	195 x 195 x 41	50	460 x 215 x 260	500	9.8 / 8.8

## Ammunition Packing

PACKAGE	AMMO	COMPONENT SPACE	TAPE SPACE	BOX SIZE	CARTON	CARTON	APPROX. GROSS WEIGHT
	(PCS)	(m/m)	(m/m)	(m/m)	(m/m)	(E/A)	(Kg)
<b>Ammunition Packing</b>							
R-1	5,000	5.0	26	255 x 50 x 150	339 x 276 x 330	60,000	12.4
R-1	5,000	5.0	52	255 x 75 x 150	339 x 276 x 330	40,000	12.4
A-405	5,000	5.0	26	255 x 50 x 150	339 x 276 x 330	60,000	13.4
A-405	5,000	5.0	52	255 x 75 x 150	339 x 276 x 330	40,000	13.4
DO-35	5,000	5.0	52	255 x 80 x 80	410 x 350 x 275	100,000	20.0
DO-41G	2,500	5.0	52	255 x 80 x 80	410 x 350 x 275	50,000	22.0
DO-41	5,000	5.0	52	255 x 75 x 150	339 x 276 x 330	40,000	19.1
DO-15	3,000	5.0	52	255 x 75 x 150	339 x 276 x 330	24,000	17.5
DO-201AE	1,250	10.0	52	255 x 75 x 150	339 x 276 x 330	10,000	17.0
DO-201AD	1,250	10.0	52	255 x 75 x 150	339 x 276 x 330	10,000	17.3
P600	400	10.0	52	255 x 75 x 150	339 x 276 x 330	3,200	11.3



## Reel Packing

PACKAGE	REEL	COMPONENT SPACE	TAPE SPACE	REEL DIA	CARTON SIZE	CARTON	APPROX. GROSS WEIGHT
	(pcs)	(m/m)	(m/m)	(EA)	(EA)	(EA)	(Kg)
Reel Packing							
R-1	5,000	5.0	52	330	340 x 340 x 410	25,000	9.0
A-405	5,000	5.0	52	330	340 x 340 x 410	25,000	9.1
DO-35	10,000	5.0	52	360	380 x 380 x 420	50,000	13.0
DO-41G	5,000	5.0	52	360	380 x 380 x 420	25,000	14.5
DO-41	5,000	5.0	52	330	340 x 340 x 410	25,000	12.4
DO-15	4,000	5.0	52	330	340 x 340 x 410	20,000	11.8
DO-201AE	1,250	10.0	52	330	340 x 340 x 410	6,250	11.0
DO-201AD	1,250	10.0	52	330	340 x 340 x 410	6,250	11.6
P600	800	10.0	52	330	340 x 340 x 410	4,000	11.4
SMA	7,500 / 1,800	4.0	-	330 / 178	375 x 360 x 390 / 390 x 240 x 420	120,000 / 72,000	17.5 / 8.3
SMB	3,000 / 500	4.0	-	330 / 178	375 x 360 x 390 / 390 x 240 x 420	48,000 / 20,000	13.6 / 7.5
SMC	3,000 / 500	12.0	-	330 / 178	375 x 360 x 390 / 390 x 240 x 420	42,000 / 15,000	16.2 / 7.3
SDIP	1,500	12.0	-	330	375 x 360 x 390	21,000	16.3
MDI	3,000 / 500	8.0	-	330 / 178	375 x 360 x 390	48,000 / 30,000	14.4
D <sup>2</sup> PCK	800	16.0	-	330	375 x 360 x 390	6,400	15.6
TO-252	3,000	8.0	-	330 / 178	375 x 360 x 390	42,000	16.5
SOD-123	10,000 / 3,000	4.0	-	330 / 178	375 x 360 x 213 / 390 x 240 x 420	120,000 / 150,000	8.0 / 10.0
SOD-323	12,000 / 5,000	4.0	-	330 / 178	375 x 360 x 213 / 390 x 240 x 420	144,000 / 250,000	9.6 / 10.0
SOT-23	12,000 / 3,000	4.0	-	330 / 178	375 x 360 x 213 / 390 x 240 x 420	144,000 / 150,000	9.6 / 10.0
SOT-323	12,000 / 3,000	4.0	-	330 / 178	375 x 360 x 213 / 390 x 240 x 420	144,000 / 150,000	9.6 / 10.0
SOT-363	3,000	4.0	-	178	438 x 438 x 220	120,000	-
SOT-23-6L	3,000	4.0	-	178	438 x 438 x 220	120,000	-
MICRO-MELF	2,500	4.0	-	178	640 x 405 x 150	200,000	15.7
QUADRO-MELF	2,500	4.0	-	178	640 x 405 x 150	200,000	15.7
MINI-MELF	2,500	4.0	-	178	640 x 405 x 150	200,000	15.7
DL-41	5,000	4.0	-	330	350 x 350 x 350	100,000	22.0



## 4. HIGH RELIABILITY TESTING SPEC.

NO	TEST ITEM	TEST CONDITION	REFERENCE DOCUMENT	LOT QUALITY LEVEL	REMARK
1	TEMPERATURE CYCLING (T.C.T)	Ta= -55+0,-3°C 10min Ta= +150+/-°C 10min FOR 20 CYCLE	MIL - STD - 750D METHOD - 1051.5	LTPD 10 S.s.=22 ACCEPT FOR 0 FAILURE ONLY.	
2	HIGH TEMPERATURE STORAGE LIFE (H.T.S.L)	Ta=150 +/- 5°C TESTING TIME: 168HRS 250HRS 500HRS	MIL-STD-750D METHOD-1031.2	LTPD10 S.s.=22 ACCEPT FOR 0 FAILURE ONLY.	
3	SOLDERABILITY TEST	TEMPERATURE OF SOLDER POT=245 +/- 5°C TIME FOR DIPPING FLUX=5-10SEC TIME FOR DIPPING IN SOLDER=5+/-0.5SEC DIPPING DEPTH=0.05 inch max FOR ONE CYCLE	MIL-STD-750D	METHOD-2026.10 LTPD 7 S.s.=32 ACCEPT FOR 0 FAILURE ONLY.	
4	HIGH TEMPERATURE REVERSE BIAS (H.T.R.B)	Ta=150 +/- 5°C VR=80%VR(CUSTOM SECP) TESTING TIME: 48HRS 96HRS 168HRS 250HRS 500HRS	MIL-STD-750D METHOD-1038.3	LTPD10 S.s.=22 ACCEPT FOR 0 FAILURE ONLY.	
5	CONTINUE FORWARD OPERATING LIFE (C.F.O.L)	Ta=55 °C I=IO +/-10% TESTING TIME: 168HRS 250HRS 500HRS	MIL-STD-750D METHOD-1027.3	LTPD10 S.s.=22 ACCEPT FOR 0 FAILURE ONLY.	
6	THERMAL SHOCK (T.S.T)	HOT TANK T=100°C+10/-2°C t=5min COLD TANK T=0°C+2/-10°C t=5min 15 CYCLE TIME BETWEEN TRANSFERRING DO'NOT EXCEED 10 SECOND.	MIL-STD-750D METHOD-1056.7	LTPD10 S.s.=22 ACCEPT FOR 0 FAILURE ONLY.	
7	PRESSURE COOKER (P.C.T)	Ta=121°C P=1.2kg/cm <sup>2</sup> TIME=96HRS	JEDEC JESD22-A102-C	LTPD10 S.s.=22 ACCEPT FOR 0 FAILURE ONLY.	
8	INTERMITTENT FORWARD OPERATING LIFE (I.F.O.L)	I = Io x 1.0 POWER ON : 30SEC POWER OFF : 50SEC TESTING TIME: 2000 CYCLES	MIL-STD-750D METHOD 1036.3	LTPD10 S.s.=22 ACCEPT FOR 0 FAILURE ONLY.	
9	FORWARD SURGE CURRENT (I.F.S.M)	SQ WAVE OR SINE WAVE IFSM=DATE SHEET SPEC. TIME=8.3Msec T=1 CYCLE	MIL-STD-750D METHOD 4066.3	LTPD10 S.s.=22 ACCEPT FOR 0 FAILURE ONLY.	
10	HUMIDITY	Ta=85°C RH=85% TESTING TIME: 168HRS 250HRS 500HRS	MIL-STD-750D METHOD 1021.1	LTPD10 S.s.=22 ACCEPT FOR 0 FAILURE ONLY.	
11	SOLDERABILITY RESISTANCE	TEMPERATURE OF SOLDER POT =260+/-5°C TIME FOR DIPPING IN SOLDER =10+2/-0 SEC DIPPING DEPTH=1.57+0.79 mm BELOW BODY FOR ONE CYCLE	MIL-STD-750D METHOD 2031.1	LTPD10 S.s.=22 ACCEPT FOR 0 FAILURE ONLY.	

SCHOTTKY PRODUCT TESTING TEMPERATURE 125 °C MAX(NORMAL)